



Electric Service Bulletin No. 750 – January, 2019

Specifications for Electrical Installations 2019



Our assistance is just a phone call away.

Help is as close as your phone. Call our local Liberty Utilities office for useful information and assistance whenever you have questions on information in this booklet.

While you're planning electrical and mechanical systems for your next project, our representatives will work closely with you and your clients.

We'll provide detailed analysis or supplemental data on all types of electrical installations.

We'll give you valuable aid before final plans are made on heating, cooling, wiring and lighting. And most important, we will suggest ways to conserve energy.

A call to Liberty Utilities will help you help yourself. Call today.

Customer Service Center	1-800-375-7413 Monday – Friday 7:00 a.m. – 5:00 p.m.
Mail Address	Liberty Utilities Customer Correspondence PO Box 1380 Londonderry, NH 03503-1380
Hearing/Speech-Impaired Customers	711
Electric and Gas Emergency Numbers <i>Does not replace 911 emergency medical services</i>	
Life-Threatening Electric Emergency	1-855-349-9455 – option 1
Life-Threatening Gas Emergency	1-855-327-7758
Power Outages	1-855-349-9455 – option 2
New Construction & Service Upgrades <i>To initiate a request for new or upgraded electric service</i>	
By Phone or email	1-800-375-7413 – (option 5) or NHElectricSRVREQ@libertyutilities.com
Online by Internet	www.libertyutilities.com Then select the appropriate state. Select "For Business Partners" Go to the section "For Technical and Construction Professionals"
For assistance with pending electric service requests, contact Operations Coordinator	1-603-952-2912 (Salem area) & 1-603-306-8236 (Lebanon/Walpole area)
For electric inspectors, to release a municipal wiring inspection	1-603-952-2912 (Salem area) & 1-603-306-8236 (Lebanon/Walpole area) or Municipal.inspectors@libertyutilities.com
New Residential or Commercial Developments	1-800-375-7413 – (option 5) or NHElectricSRVREQ@libertyutilities.com
Dig Safe Requests	1-888-DIGSAFE (1-888-344-7233) Dig Safe System Inc. 811 is the national wide number; see http://www.call811.com/state-specific.aspx
Hazard Identification Hotline When working near power lines or high voltage lines	1-800-375-7413

Also check the following Web site for this and other Liberty Utilities information: <http://www.libertyutilities.com>



January 2019

SPECIFICATIONS for ELECTRICAL INSTALLATIONS

PREFACE

This January 2019 edition of the Specifications for Electrical Installations is effective as of January 2019. These specifications provide practical answers to common questions about our Companies' electrical services but cannot take the place of person to person assistance. We encourage you to call us at any time for advice and further information. Our local telephone numbers are listed inside the cover of this booklet.

These specifications, which protect the mutual interests of the Customer and Company, may be revised or amended from time to time in keeping with developments and progress of the industry. For the latest official version of this document please visit the Company's web site address. Printed copies of these specifications are not document controlled and may be obtained from the Company by contacting the applicable Customer Service Centers in Lebanon and Salem, New Hampshire. Therefore, the on-line version will always prevail over any uncontrolled printed documents.

Our Customer Care departments offer several programs that can be profitable for you and your client, and that promote the efficient use of electricity. Call us for details we look forward to working with you to provide the best electric service possible. To make this possible, we ask that you submit suggestions on revisions to this document by completing the form located at the end of this booklet and mailing it to the address shown on the form.

Thank you.

TABLE OF CONTENTS

<u>SECTION</u>	<u>PAGE</u>
PREFACE	1
TABLE of CONTENTS	2
PROCESS AND INFORMATION	9
<i>Obtaining Electric Service</i>	9
<i>Electric Service Areas</i>	
Liberty Utilities in New Hampshire:	11
<i>Safety Information</i>	12
<i>Contacting the Company</i>	12
PART A – “GENERAL INFORMATION”	13
1.0 INTRODUCTION	13
1.1 PURPOSE	13
1.2 SCOPE	13
1.3 RATE SCHEDULE	13
1.4 COOPERATION AND TIME REQUIREMENTS.....	13
1.5 CODES, STANDARDS, AND REFERENCES	13
FIGURE 1.5-1 – ILLUSTRATION UTILITY ELECTRIC SUPPLY AND PREMISES WIRING	14
1.5.1 <i>References</i>	15
1.5.2 <i>Supplemental Company Specifications</i>	15
1.6 REQUESTS FOR INFORMATION.....	15
1.7 CUSTOMER’S RESPONSIBILITY	15
1.7.1 <i>All Customers</i>	15
1.7.2 <i>Customers served at voltages above 600 volts</i>	16
1.8 COMPANY’S RESPONSIBILITIES.....	16
1.9 INSPECTION, WIRING ADEQUACY, AND ENFORCEMENT	16
1.10 DISCLAIMER.....	17
1.10.1 <i>Company Approval</i>	17
1.10.2 <i>Use of Electricity</i>	17
1.10.3 <i>Condition of Service</i>	17
1.10.4 <i>Company Warranty Statement</i>	17
1.11 ENFORCEMENT OF COMPANY REQUIREMENTS	18
1.11.1 <i>Enforcement Criteria</i>	18
1.11.2 <i>Diversion of Electrical Energy</i>	18
2.0 DEFINITIONS	19
<i>Figure 2-1: Typical Service Installation Diagram Below 600 volts – Excluding Network</i>	19
3.0 GENERAL SERVICE CONNECTION REQUIREMENTS	24
3.1 APPLICATION FOR SERVICE	24
3.1.1 <i>Application</i>	24
3.1.2 <i>Public grants and special permits</i>	24
3.1.3 <i>Easements</i>	24
3.2 NUMBER OF SERVICES.....	24
3.2.1 <i>With Respect to Building and Premise</i>	24
3.2.2 <i>Electricity Delivered Through More Than One Meter</i>	24
3.2.3 <i>Multiple Service Requests</i>	25
3.3 TEMPORARY SERVICE	25
3.3.1 <i>Company Facilities</i>	25
3.3.2 <i>Location</i>	25
3.3.3 <i>Equipment</i>	25
3.3.4 <i>Duration</i>	26
3.3.5 <i>Cost</i>	26

TABLE OF CONTENTS

<u>SECTION</u>	<u>PAGE</u>
3.4	ACCESS..... 26
3.5	IDENTIFICATION OF EMPLOYEES..... 26
3.6	CHARACTER OF SERVICE 26
3.7	VOLTAGES AVAILABLE..... 27
3.7.1	<i>Available Services</i> 27
Table 3.7.1-1	- Available Services Below 600 volts..... 27
3.7.2	<i>New Customers (Applicants)</i> 27
3.7.3	<i>Existing Customers</i> 28
3.7.3.1	Customer Expansion 28
3.7.3.2	Voltage Migration at Customer's Request 28
3.7.3.3	Voltage Migration at Company's Request 28
3.8	SERVICES NO LONGER STANDARD..... 28
3.9	LOAD BALANCE 28
3.10	INCREASE IN SERVICE..... 28
3.11	UNAUTHORIZED ATTACHMENTS..... 29
3.12	DISCONTINUANCE OF SERVICE 29
PART B – “ELECTRIC SERVICE REQUIREMENTS”	30
4.0	SERVICE CONNECTIONS 30
4.1	GENERAL..... 30
4.1.1	<i>Rights-of-Way, Easements</i> 30
4.1.2	<i>Number, Routing and Location of Service Laterals or Service Lines</i> 30
4.1.3	<i>Relocation of Service Laterals</i> 31
4.1.4	<i>Allowable Voltage Drop</i> 31
4.1.5	<i>Minimum Size-Single Phase Service Connections</i> 31
4.1.6	<i>Service Conductor Splicing</i> 31
4.1.7	<i>Routing of Metered and Unmetered Conductors</i> 31
4.1.8	<i>Inhibiting Grease</i> 32
4.1.9	<i>Electric and Gas Meter Clearances</i> 32
Figure 4.1.9-1	<i>Electric Meter to Gas Meter Clearances</i> 32
4.1.10	<i>Temporary Service</i> 32
Figure 4.1.10-1	<i>Typical Overhead Service Pole for Permanent or Temporary Service Below 600V</i> 33
Figure 4.1.10-2	<i>Temporary Overhead Service Below 600 volts</i> 34
Figure 4.1.10-3	<i>Temporary Underground Service Below 600 volts</i> 35
4.1.11	<i>Fire Alarm and Emergency Systems</i> 35
4.1.11.1	Fire Alarms..... 35
4.1.11.2	Emergency Systems 35
4.1.12	<i>Service to Manufactured and Mobile Homes, Mobile Home Parks, and Recreational Vehicle Parks</i> 36
4.1.12.1	Service to Manufactured and Mobile Homes and Mobile Home Parks 36
4.1.12.2	Service to Recreational Vehicle Parks 37
4.2	OVERHEAD SECONDARY VOLTAGE SERVICE CONNECTION (Under 600V) 37
4.2.1	<i>General</i> 37
Figure 4.2.1-1	<i>Typical Overhead Service Installation under 600V</i> 37
4.2.2	<i>Service Attachment, Location</i> 38
Figure 4.2.2-1	<i>Typical Residential Overhead Service under 300 volts and 400 amperes</i> 38
4.2.3	<i>Customer-owned Service Pole</i> 39
4.2.4	<i>Overhead Service Line Clearances</i> 39
4.2.4.1	General Overhead Service Line Clearances..... 39
4.2.4.2	Clearances to Swimming Pools 40
4.2.4.3	Service to Low Buildings 40
Table 4.2.4.3-1	- Galvanized Riser Mast Bracing Requirements 41
Figure 4.2.4.3-1	<i>Overhead Service Attachment and Riser Mast Requirements</i> 42

TABLE OF CONTENTS

<u>SECTION</u>		<u>PAGE</u>
4.2.5	<i>Service Drop and Connection to Service Conductors</i>	43
4.2.6	<i>Customer's service meters are not allowed on Company owned poles</i>	43
4.3	OVERHEAD PRIMARY VOLTAGE SERVICE CONNECTION (2.4kV to 46kV inclusive).....	43
4.4	UNDERGROUND SECONDARY SERVICE VOLTAGE CONNECTION (Under 600V).....	44
4.4.1	<i>General</i>	44
4.4.2	<i>Facilities in Shared Trench</i>	44
4.4.3	<i>Conduit System</i>	44
4.4.4	<i>Underground Secondary Service Connection from the Company's Overhead Distribution Supply</i>	45
4.4.4.1	<i>Residential Underground Secondary Service Conductors</i>	45
4.4.4.2	<i>Commercial Underground Secondary Service Conductors</i>	45
4.4.4.3	<i>Company Riser Pole Attachments</i>	45
	<i>Figure 4.4.4.2-1 Commercial Underground Secondary Service Riser Pole Detail</i>	46
4.4.5	<i>Underground Secondary Service Connection from the Company's Underground Supply Lines</i>	46
4.4.5.1	<i>General</i>	46
	<i>Figure 4.4.5-1 Underground Residential Distribution (URD)</i>	47
	<i>Figure 4.4.5-2 Underground Secondary Service Residential Meter Connection – Conduit</i>	49
4.4.6	<i>Underground Secondary Service Connection</i>	49
4.4.6.1	<i>From a Company-owned Primary Underground Service Lateral</i>	49
4.4.6.2	<i>Service to Multiple Occupancy Buildings</i>	49
4.5	UNDERGROUND PRIMARY VOLTAGE SERVICE CONNECTION.....	50
5.0	SERVICE EQUIPMENT	51
5.1	GENERAL.....	51
5.1.1	<i>Service Equipment Required</i>	51
5.1.2	<i>Service Equipment Minimum Continuous Current Rating</i>	51
5.1.3	<i>Service Equipment Minimum Short Circuit Withstand Capability</i>	51
5.1.4	<i>Routing of Metered and Unmetered Conductors</i>	51
5.1.5	<i>Taps Ahead of Main Service Equipment</i>	51
5.1.6	<i>When Service Equipment Ahead of Metering is Required</i>	51
5.1.7	<i>Service Equipment on Service Poles, Pedestals, or Posts</i>	52
5.1.8	<i>Grouped Metered Services to Separate Buildings on One Premise</i>	52
5.1.9	<i>Service Equipment Arrangement</i>	52
5.1.10	<i>Service Equipment Minimum Attributes</i>	53
5.1.10.1	<i>Interrupting Rating</i>	53
5.1.10.2	<i>Inductive Heating</i>	53
5.1.10.3	<i>Metering Transformer Space</i>	53
5.1.10.4	<i>Bonding</i>	53
5.1.10.5	<i>Spare Fuses</i>	53
5.1.10.6	<i>Circuit Breaker</i>	53
5.1.11	<i>Instrumentation and Control Wiring</i>	53
5.2	RESIDENTIAL.....	53
5.3	NETWORK SERVICE.....	53
5.3.1	<i>General</i>	53
5.4	RADIAL SERVICES.....	54
5.4.1	<i>More than Six Service Disconnects</i>	54
5.4.2	<i>Radial Service, 300 amperes Continuous or Less Served at Less Than 600 volts</i>	54
5.4.3	<i>Radial Service, Above 300 amperes Continuous Served at Less Than 600 volts</i>	54
5.5	INDIVIDUAL MULTIPLE OCCUPANCY BUILDING SERVICE.....	54
5.6	RADIAL LOADS SERVED ABOVE 600 VOLTS.....	55
6.0	GROUNDING	56
6.1	GENERAL.....	56
6.2	EQUIPMENT TO BE GROUNDED.....	56

TABLE OF CONTENTS

<u>SECTION</u>		<u>PAGE</u>
6.3	GROUNDING METHODS	56
6.4	GROUNDING RESTRICTIONS	56
6.5	GROUND FAULT PROTECTION.....	56
7.0	METERING.....	57
7.1	GENERAL.....	57
7.1.1	Access.....	57
7.1.3	Working Clearances	57
7.1.3.1	Indoor Installations.....	57
7.1.3.2	Outdoor Installations.....	57
7.1.4	Physical Protection	58
7.1.5	Violations.....	58
7.1.6	Unmetered Wiring.....	58
7.1.7	Taps Ahead of Metering	58
7.1.8	Meter Relocation.....	58
7.1.9	Group Metering.....	59
7.1.10	Emergency System Metering.....	59
7.1.11	Shared Metering	59
7.2	METER APPLICATIONS AND REQUIREMENTS 600 VOLTS AND LESS	59
	Table 7.2-1 Meter Socket and Transformer-rated Meter Applications	59
	Table 7.2-2 Self-contained Meter Socket Requirements	60
	Note: Meter Socket Minimum Short Circuit Withstand Capability.....	61
	Table 7.2-3 General Self-contained Meter Socket Installation Responsibilities Checklist.....	61
	Table 7.2-4: 320A Meter Socket Applications.....	61
7.3	SELF-CONTAINED METER SOCKET INSTALLATIONS	62
	Figure 7.3-1 Typical Single Phase Residential or Commercial Meter Socket Connections 120/240 Volt, 3 Wire, 200 Ampere Maximum Continuous Duty.....	62
	Figure 7.3-2 Typical Single Phase Residential URD Meter Socket Connection 120/240 Volt, 3 Wire, 200 Ampere Maximum Continuous Duty.....	63
	Figure 7.3-3 Typical Single Phase Residential or Commercial Meter Socket Connections 120/240 Volt or 120/208 Volt or 277/480 Volt, 3 Wire, 320 Ampere Maximum Continuous Duty.....	64
	Figure 7.3-4 Typical Single Phase Residential or Commercial Meter Socket Connections 120/208 Volt and 277/480 Volt, 3 Wire, 200 Ampere Maximum Continuous Duty.....	65
	Figure 7.3-5 Typical Three Phase Commercial Meter Socket Connections 208Y/120 Volt and 480Y/277 Volt, 4 Wire, 200 Ampere Maximum Continuous Duty.....	66
	Figure 7.3-6 Typical Three Phase Commercial Meter Socket Connections 208Y/120 Volt and 480Y/277 Volt, 4 Wire, 320 Ampere Maximum Continuous Duty.....	67
	Figure 7.3-7 Typical Single Phase Residential or Commercial 2-to-6 Ganged Meter Socket Connections 3 Wire, 120/240 Volt 150 Ampere and 120/208 Volt 100 Ampere, Maximum Continuous Duty per Position.....	68
	Figure 7.3-8 Typical Residential or Commercial Service Pedestal Single Phase Service 120/240 Volt 200 Amp and 120/208 Volt 100 Amp, 3 Wire	69
	Figure 7.3-9 Typical Residential or Commercial Meter Center (more than six meters) Single Phase and Three Phase Service 120/240 Volt 200 Amp and 120/208 Volt 100 Amp, 3 Wire and 208Y/120 Volt, 4 Wire.....	70
	Figure 7.3-10 Typical Mobile Home and Recreational Vehicle Park Meter Socket Applications.....	71
7.4	TRANSFORMER-RATED METERING 600 VOLTS AND LESS, 400 AMPS AND ABOVE	72
7.4.1	Instrument Transformers and Enclosures.....	72
	Figure 7.4.1-1 Typical Commercial CT Cabinet Secondary Metering Installation.....	73
	Figure 7.4.1-2 Typical Indoor Commercial Installation Two to Six Meter Service Entrance 800A Maximum From Overhead Line	74
	Figure 7.4.1-3 Typical Indoor Commercial Installation One Meter Service Entrance from Network or Radial Underground Line Three-Phase, 4 Wire, 208Y/120V, 400A.....	75
	Figure 7.4.1-4 Typical Outdoor Service Pole Installation Single-Phase, 3 Wire, 120/240V for Loads 72 to 100kVA Demand or Three-Phase up to 800A From Overhead Line	76
7.4.2	Meter Sockets.....	77
7.4.3	Metering Sequence.....	77
7.4.4	Instrument Transformer Secondaries	77
7.4.5	Pad-mounted Transformer Service Metering.....	77

TABLE OF CONTENTS

<u>SECTION</u>		<u>PAGE</u>
7.4.6	<i>Metal-Enclosed Free-Standing Service Cubicles Rated 600 volts or Less (Secondary Voltage Installations)</i>	77
7.4.6.1	General.....	77
7.4.6.2	Metering Sequence.....	77
Figure 7.4.6.2-1:	Instrument Transformer Metering Sequence - Service Cubicles Rated 600 volts.....	78
7.4.6.3	Unmetered Supply Conductors.....	78
7.4.6.4	Meter Location.....	78
7.4.6.5	Customer's Auxiliary Equipment.....	79
7.4.6.6	Metering Transformer Equipment Compartment.....	79
Figure 7.4.6.6-1:	Metering Instrument Transformer Compartment in Service Cubicles Rated 600V.....	80
7.4.6.7	Voltage Transformers.....	80
7.5	METERING ABOVE 600 VOLTS.....	81
7.6	METERING PULSE SIGNALS.....	81
7.7	METER BOARDS AND SUPPORTS.....	81
7.7.1	<i>Meter Mounting</i>	81
7.7.2	<i>Approved Materials</i>	81
8.0	MOTORS AND CONTROLLERS.....	82
8.1	GENERAL.....	82
8.2	SINGLE PHASE MOTORS.....	82
8.2.1	<i>120 Volt Supply</i>	82
8.2.2	<i>208 or 240 Volt Supply</i>	82
8.2.3	<i>Maximum Locked-Rotor Currents</i>	82
8.2.4	<i>Single-Phase Motors on Three-Phase Service</i>	82
8.3	THREE-PHASE MOTORS.....	83
8.3.1	<i>Size of Motors</i>	83
8.3.2	<i>Maximum Locked-Rotor Currents</i>	83
8.4	MOTOR PROTECTION.....	83
8.4.1	<i>Overload Protection</i>	83
8.4.2	<i>Protection Against Single-Phase Operation</i>	83
8.4.3	<i>Reverse Phase Protection</i>	83
8.4.4	<i>Undervoltage Protection</i>	83
8.5	MOTOR-STARTING REQUIREMENTS.....	83
8.5.1	<i>Objectionable Voltage Variation</i>	83
8.5.2	<i>Current Inrush Limitation</i>	84
8.5.3	<i>Favorable Locations</i>	84
8.5.4	<i>Company Notification of 3 HP Single Phase and 10 HP Three Phase Applications</i>	84
8.6	MAXIMUM PERMITTED STARTING CURRENT.....	84
Table 8.6-1	<i>Single Phase Motor Starting Current</i>	85
Table 8.6-2	<i>Three Phase Motor Starting Current</i>	85
9.0	TRANSFORMER INSTALLATIONS ON CUSTOMER PREMISES.....	86
9.1	GENERAL.....	86
9.2	INSTALLATIONS.....	86
9.2.1	<i>Cluster Mounted Overhead Transformers</i>	86
9.2.2	<i>Outdoor Single Phase Pad Mounted Transformer</i>	86
Table 9.2.2.2-1	<i>Company and Customer Outdoor Single Phase Pad Mounted Transformer Provisions</i>	87
9.2.3	<i>Outdoor Three Phase Pad Mounted Transformer</i>	87
9.2.4	<i>Transformer Vault in Non-Network Area</i>	87
9.3	AVAILABLE FAULT CURRENT.....	87
9.3.1	<i>Network Services</i>	87
9.3.2	<i>Single Phase Transformers</i>	87
Table 9.3.2-1	<i>Single Phase Transformers Available Fault Current</i>	87
9.3.3	<i>Three Phase Overhead Transformers</i>	88
Table 9.3.3-1	<i>Three Phase Overhead Transformer Available Fault Current</i>	88
9.3.4	<i>Three Phase Pad Mounted Transformers</i>	88
Table 9.3.4-1	<i>Three Phase Pad Mounted Transformer Available Fault Current</i>	88

TABLE OF CONTENTS

<u>SECTION</u>		<u>PAGE</u>
10.0	DISTURBANCES AND POWER QUALITY.....	89
10.1	GENERAL.....	89
10.2	MOTORS.....	89
10.3	DEVICES WITH INTERMITTENT HIGH CURRENT.....	89
10.4	AUTOMATIC RECLOSING.....	89
10.5	ELECTRICAL INTERFERENCE.....	89
	<i>Table 10.5-1 Harmonic Current Limits for Non-Linear Loads at the Point-of-Common-Coupling (PCC) with Other Loads, at Voltages of 120V to 69kV.....</i>	<i>90</i>
	<i>Table 10.5-2 Harmonic voltage limits for power producers (Public Utilities or Non-Utility Generators).....</i>	<i>90</i>
10.6	POWER SUPPLY TO VOLTAGE SENSITIVE EQUIPMENT AND COMPUTERS.....	90
10.7	ISOLATION TRANSFORMER.....	90
	<i>Table 10.7-1 – Minimum Number of Single-phase Transformers to Serve Reduced-voltage Load on a 3-phase, 3-wire Service.....</i>	<i>91</i>
10.8	VOLTAGE TOLERANCE BOUNDARY.....	91
11.0	CUSTOMER-OWNED ELECTRIC SOURCES – INCLUDING STANDBY GENERATORS.....	92
11.1	GENERAL.....	92
11.2	EMERGENCY AND STANDBY ELECTRIC SOURCES.....	92
11.2.1	<i>Compliance Criteria.....</i>	<i>92</i>
	<i>Figure 11.2.1-1 Standby Generator Non-parallel Operation with Company Connection Supplying Customer's Entire Load</i>	<i>94</i>
	<i>Figure 11.2.1-2 Connection of Standby Generator Supplying One 120 volt Branch Circuit.....</i>	<i>94</i>
	<i>Figure 11.2.1-3 Connection of Standby Generator Supplying One Building From Customer's Main Distribution Point.....</i>	<i>95</i>
11.2.2	<i>Electric Source Type & Installation Method.....</i>	<i>96</i>
11.2.2.1	AC or DC.....	96
11.2.2.2	Separately Derived Systems.....	96
11.2.2.3	Temporary Emergency Connections.....	96
11.2.3	<i>Transfer Systems.....</i>	<i>96</i>
11.2.3.1	Service Equipment Rated Transfer.....	96
11.2.3.2	Open-Transition Transfer.....	96
	<i>Figure 11.2.3.2-1 Double Throw Safety Transfer Switch.....</i>	<i>97</i>
11.2.3.3	Closed Transition & Auto Transfer.....	98
	<i>Table 11.2.3.3-1 Relay settings to parallel standby or emergency generators with the Company system.....</i>	<i>98</i>
11.2.4	<i>Identification and Clearances.....</i>	<i>98</i>
11.3	PARALLEL ELECTRIC POWER PRODUCTION.....	99
11.3.1	<i>Inverters.....</i>	<i>99</i>
12.0	UTILIZATION AND SPECIAL EQUIPMENT.....	100
12.1	ELECTRIC FENCES.....	100
12.2	SIGNS AND AUTOMATICALLY CONTROLLED LIGHTING.....	100
12.3	LIGHTNING AND SURGE PROTECTION.....	100
12.4	POWER FACTOR CORRECTION CAPACITORS.....	100
12.4.1	<i>Capacitor Installation.....</i>	<i>100</i>
12.4.2	<i>Static VAR Compensators (SVC).....</i>	<i>100</i>
12.5	RADIO AND TELEVISION.....	101
12.5.1	<i>Transmitting Station, Repeater, or High Frequency Equipment.....</i>	<i>101</i>
12.5.2	<i>Antennas.....</i>	<i>101</i>
12.5.3	<i>Eliminator or Trap.....</i>	<i>101</i>
12.6	CARRIER CURRENT SYSTEMS.....	101

TABLE OF CONTENTS

<u>SECTION</u>	<u>PAGE</u>
13.0 REVISION HISTORY	102
PART C – “APPENDICES”	103
APPENDIX 1 - OVERHEAD ATTACHMENT METHODS	103
<i>Table App1-1 – Company-accepted Attachment Materials.....</i>	<i>103</i>
<i>Figure App1-1 – Illustrated Details of Overhead Service Attachment Methods: Details</i>	<i>105</i>
<i>FIGURE APP1-2 – ILLUSTRATED DETAILS OF OVERHEAD SERVICE ATTACHMENT METHODS: ANCHORING ..</i>	<i>106</i>
APPENDIX 2 - TRAFFIC CONTROL METERED SERVICE REQUIREMENTS	107
<i>Notes for Figure App2-1</i>	<i>107</i>
<i>Figure App2-1 – Typical Traffic Control Metered Service Installation</i>	<i>108</i>
APPENDIX 3 - DISTRIBUTION WOOD POLE MOUNTED METER POWER SUPPLY INSTALLATION.....	109
APPENDIX 4 - ESB No. 759C Residential Underground Services.....	111
CHANGE PROPOSAL FOR LIBERTY UTILITIES “SPECIFICATIONS FOR ELECTRICAL INSTALLATIONS”115	

January 2019

PROCESS AND INFORMATION

Obtaining Electric Service

Please refer to the inside front cover of this book for Company contact information by phone, facsimile, mail, or internet.

How to Obtain Electric Service (less than 600 volts)	
(Applicants and Existing Customers)	
Pre-Plan Step 1	<ul style="list-style-type: none"> ✓ Review the Service Territory Map in the following pages of this book to determine the availability of electric service where application is made. ✓ Determine the amperage size and voltage of service needed; see the latest National Electrical Code. ✓ Determine the type of service desired as permitted. ✓ If heating with electricity, determine the total square footage of the area to be heated. ✓ Determine the desired date electric service is to be energized (provide for applicable planning, material order, and construction schedules). A Customer Order Fulfillment representative will make contact to confirm if the desired date can be met by the Company.
Request Step 2	<ul style="list-style-type: none"> ✓ For Applicants for a new electric service: <ul style="list-style-type: none"> ▪ The individual or entity who will be responsible for the electric bill must apply for service by contacting the Company's state-applicable Customer Service Center. ▪ Applicants may be required to submit written application and provide a security deposit according to the applicable Company tariff, which will be conveyed at the time the Applicant contacts the Company to request a new service in their name. ▪ The Applicant or their designated representative may initiate the service order by mail, facsimile, internet or telephone. When applying by <u>mail or facsimile</u>, an electric service request form is available from the Company's state-applicable Customer Service Center. Fill out the form providing the following information: <ul style="list-style-type: none"> ✓ Customer name, mailing address, phone number and daytime contact information ✓ The address where electric service is to be delivered and specific directions, including the nearest intersection ✓ The name, address and telephone number of the electrical contractor, if one will be used ✓ The specifics about type and size of service as defined above ✓ The proposed date for electric service (may require re-negotiation once Company work scope is defined) When applying by <u>internet</u>, navigate to the new service order form for Electricity by going to the website for the applicable state and selecting the topic "For Technical and Construction Professionals." Click on the link for "Electric Service" to open the online form. When applying by <u>telephone</u>, be prepared to provide the information provided on the electric service request form. ✓ To request an upgrade, relocation or rewire of an existing electric service, the Customer or their designated licensed electrical contractor may initiate the request by mail, facsimile, internet or telephone. Contact the Company's state-applicable Customer Service Center. For residential single-phase services, information which will assist in potentially expediting the request includes: the service location, service pole, and meter location if the service remains at the same location and if there are no clearance violations caused by pools, additions, garages, or decks. Where there is a clearance issue or if the attachment is inaccessible by ladder from the ground, the Company designates the service location. ✓ To request a temporary service, the request should be made by the individual or entity responsible for payment of charges associated with the temporary service. Payment is required in advance of scheduling the installation of a temporary service according to the applicable Company tariff. ✓ If an easement is required, the Applicant or Customer completes an Easement Application Form.

January 2019

How to Obtain Electric Service (cont'd) (less than 600 volts)	
(Applicants and Existing Customers)	
Plan Step 3	<ul style="list-style-type: none"> ✓ Consult the Company regarding the type of service available and typical scheduling before plans are completed, the equipment is purchased, and construction is started. <ul style="list-style-type: none"> ▪ For <u>residential developments, commercial, and industrial applications</u>, an AutoCAD or Microstation (if available) electronic copy of the site plan, with grades and curb cuts may be e-mailed to the Company. ▪ For <u>400-ampere services and larger and distributed generation and standby generator proposed installations</u>, a one-line diagram must be submitted to the Company indicating service voltage; size of main switch or sub-mains if more than one; number, size, and type of conductors; number, size, and material of conduits, number of meters, their location and whether they are self-contained or transformer rated. The diagram must include information from the service attachment point to the main disconnect switch and overcurrent device (i.e. service equipment). ✓ Secure appropriate property rights (easements, licenses, permits, etc.) prior to the installation of any electrical service. ✓ Contribute to the cost of the service installation and connection to the Company's distribution system if the line on private property exceeds the allowance as provided in the Company's applicable tariff.
Installation Step 4	<ul style="list-style-type: none"> ✓ The Company's work can be scheduled only after the Company has received all documents and payment toward construction, if required. ✓ Complete the electrical wiring. ✓ Obtain any required electrical permits and arrange electrical inspection. ✓ Provide a completed "Certificate of Electrical Inspection" to the Company. ✓ Follow the Company's disconnect/reconnect policy for rewires/upgrades for less than 200-ampere single-phase overhead residential services only. <p>Note: Licensed electricians or qualified electrical contractors have several options to perform this work, providing they are using the same Point of Attachment. Contact the Company's Customer Order Fulfillment for a representative to review the details for the available policy in your area.</p> ✓ Provide a completed "Certificate of Compliance to Minimum Insulation Standards" to the Company if an <u>existing home is converted to electric heat</u>. ✓ Provide appropriate property rights for the Company's facilities, as required. ✓ Pay any charges that might be required by the Company according to its applicable tariff.

Liberty Utilities in New Hampshire:

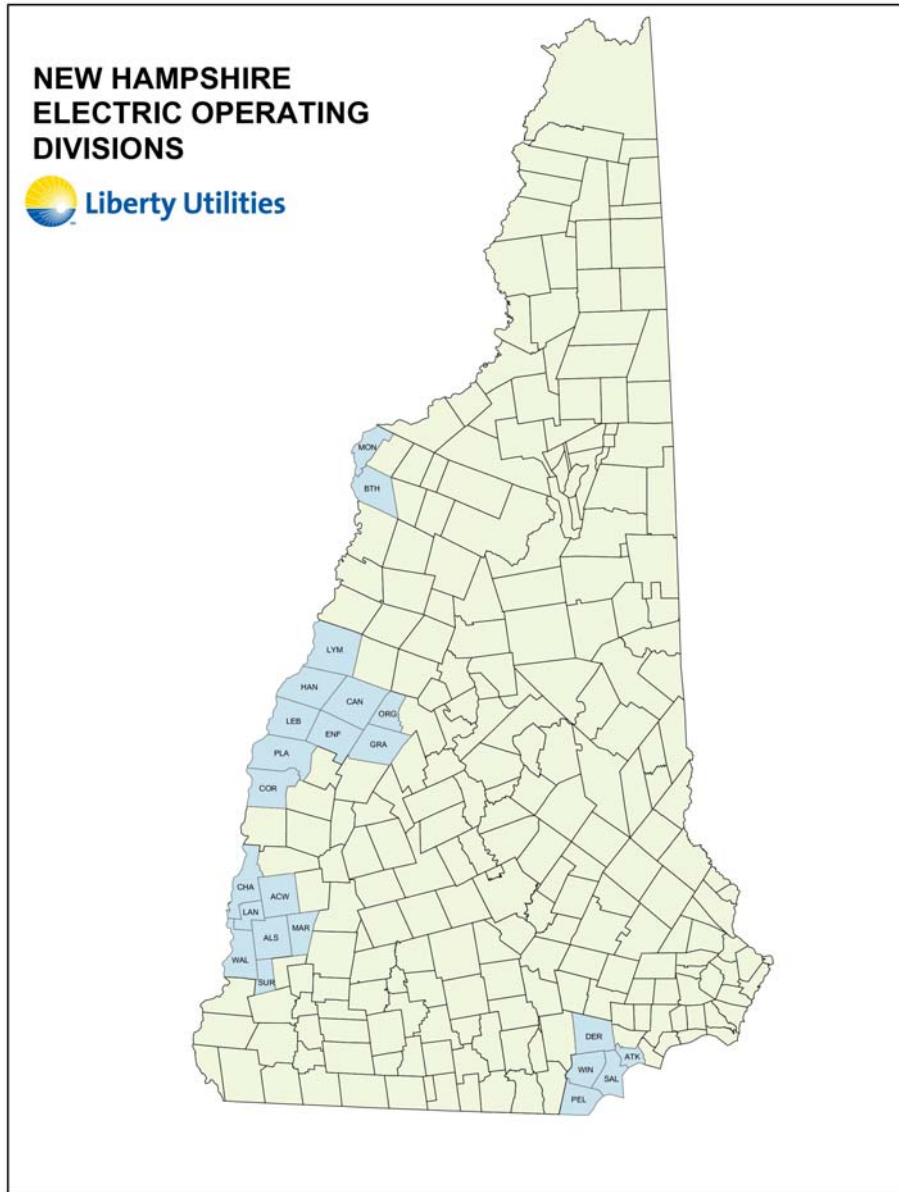

[http://libertyutilities.com/east/electricity/about/communities we serve.html](http://libertyutilities.com/east/electricity/about/communities_we_serve.html)

SERVING THESE COMMUNITIES:

- | | | | |
|--------------|----------|------------|----------|
| Acworth | Cornish | Lyme | Salem* |
| Alstead | Derry | Marlow | Surry |
| Atkinson | Enfield* | Monroe* | Walpole* |
| Bath* | Grafton | Orange | Windham |
| Canaan | Hanover* | Pelham* | |
| Charlestown* | Lebanon* | Plainfield | |

*Served exclusively by Liberty Utilities

January 2019

Safety Information

Liberty Utilities is committed to the pursuit of safety excellence through compliance with all OSHA, State, and Regulatory requirements. We encourage the Customer or its Contractor to comply with the same requirements and for safe trenching.

811 is the nationwide number for utility locate requests before trenching; see:

<http://www.call811.com/state-specific.aspx>

In the New England states:



<http://www.digsafe.com/>

For Utility Locate Requests call: 1-888-DIGSAFE (344-7233) or Apply Online

The Electrical Safety Foundation International (ESFI):



<http://esfi.org/>

For worker safety precautions as applicable for the installation, please refer to:

- NESC ANSI C2,
- NFPA 70E,
- OSHA, and
- any state and local requirements.

Contacting the Company

Please refer to the inside front cover for important phone numbers and our Internet Web sites for Liberty Utilities information in the USA.

<http://libertyutilities.com/>

Part A – “General Information”

Note: The information provided in Part A contains common general conditions of electric service based upon state laws and regulations that govern the authority of utilities to provide electric service under applicable tariffs. While each utility's requirements may vary from state-to-state, most states have adopted some form of the National Electrical Safety Code (NESC). The NESC is an adoptable code promulgated by IEEE through the ANSI standards-making process.

1.0 INTRODUCTION

1.1 PURPOSE

The purpose of this document is to provide Liberty Utilities' general electric service rules for basic requirements essential for maintaining satisfactory service or interconnection compatible with Liberty Utilities' electric power system (EPS). In addition, these rules are intended to properly protect the safety and interests of Liberty Utilities' customers and others served by the electric power system (EPS) operated by the utility. Where the term “Company” is used, it refers to the applicable serving utility within Liberty Utilities' service territories. These basic rules are supplemented by the applicable tariffs in effect in each of the Company's service territories; as such tariffs may be amended from time to time.

1.2 SCOPE

These electric service requirements cover conductors and equipment connecting the Company's EPS at the Customer's service point. These also include other topics associated with the supply of electricity that are of mutual interest to the Company, customers, design professionals, and qualified installers. It should be noted that this is not a complete set of rules governing the electrical premises wiring and equipment.

1.3 RATE SCHEDULE

Electric tariffs and associated rules and regulations are on file with the applicable state regulatory agencies and are also available for download from the Company's website for each state. The following are the associated Liberty Utilities tariffs for these specifications; as such tariffs may be amended from time to time:

- In New Hampshire, “Tariff for Retail Delivery Service”

1.4 COOPERATION AND TIME REQUIREMENTS

The Customer, its authorized agent and/or design professional is responsible for cooperating with the Company and permitting a thorough and proper technical review by the Company for acceptance and timely delivery of the Company's services. Preliminary information leading to new or increased electric service requirements shall be submitted to the Company early in the planning stages. This will insure proper design and scheduling coordination of the work associated with the service connection.

1.5 CODES, STANDARDS, AND REFERENCES

These rules supplement, and may exceed standards of safety regarding the Customer's electrical installation set forth in the National Electrical Code (NEC) and the National Electrical Safety Code (NESC) and other applicable codes. These rules are not a substitute for the NEC, NESC, municipal codes, or any other authority having jurisdiction.

The Company requires that the Customer's premises wiring installations be made in accordance with all applicable codes and these rules. Service shall be denied if these codes and the Company's rules are not met. The Company accepts no liability for direct or indirect damages resulting from the Company's refusal to energize a service or the Company's termination of a service that does not meet these rules and all other applicable codes.

The following is a general illustration of where the Company's electric supply and the Customer's premises wiring meet for what is covered and what is not covered by the NEC as described in NEC Section 90.2. Local conditions of service may permit the Company's metering to be installed at any point on either side of the service point; see 90.2(B) (5) in the NEC. Conditions of electric service are based on governmental laws or regulations that determine the Company's authority to provide electric service under their tariffs. These conditions of electric service affect the location of the service point and facilities under the Company's exclusive control.

FIGURE 1.5-1 – ILLUSTRATION UTILITY ELECTRIC SUPPLY AND PREMISES WIRING

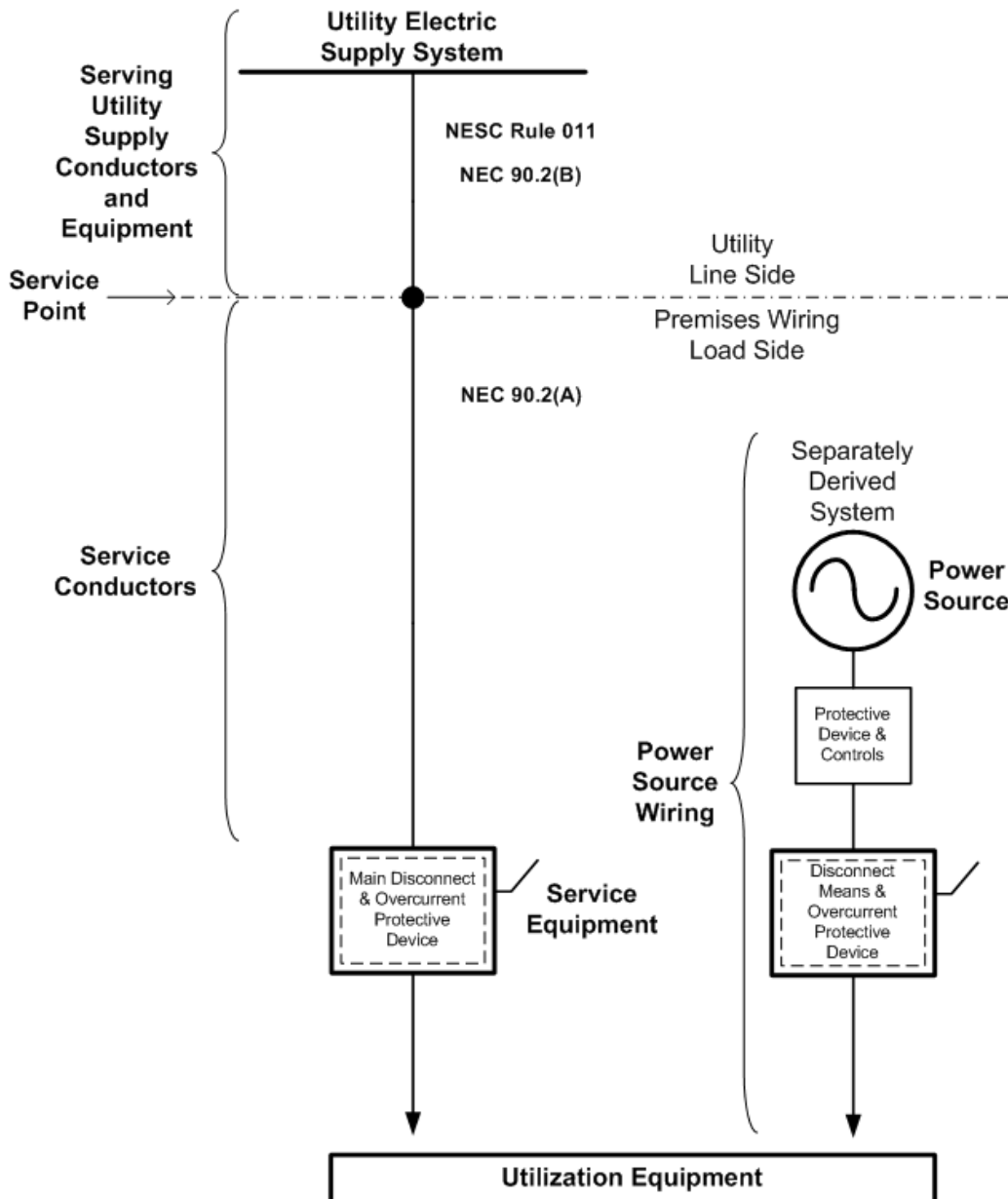

January 2019

1.5.1 References

NFPA 70	National Electrical Code
NFPA 70B	Recommended Practice for Electrical Equipment Maintenance
NFPA 70E	Standard for Electrical Safety in the Workplace
ANSI/IEEE C2 Building Code	National Electrical Safety Code
New Hampshire Revised Statutes:	States of New Hampshire
	Chapter 374, Sections 48-56
	Chapter 539, Section 7
Federal Occupational Safety and Health Administration (OSHA)	29 CFR 1926.550(a)(15)
	29 CFR 1926.651 (a)
	29 CFR 1910.333 (c)
Excavation Notification Requirements - Dig Safe	In NH: 1-888-DIGSAFE (344-7233)
	811 is the nationwide number; see http://www.call811.com/state-specific.aspx

1.5.2 Supplemental Company Specifications

ESB No. 756	Requirements for Distributed Generation Connected to a Liberty Utilities Owned Distribution EPS
ESB No. 759A	Underground Residential Distribution Guideline
ESB No. 759B	Underground Commercial Distribution Guideline
ESB No. 759C	Underground Residential Services (See Appendix - 4)

See these Electric System Bulletins at <http://www.libertyutilites.com/electricalspecifications>

1.6 REQUESTS FOR INFORMATION

The Company invites inquiries and will assist the Customer with the application of these rules. Refer to the "Process and Information" section in the beginning of this book.

1.7 CUSTOMER'S RESPONSIBILITY

1.7.1 All Customers

The Customer shall provide the service entrance, in accordance with the Company's requirements, and all premises wiring on the load side of the service point. At all times, the Customer is responsible for ensuring that its electrical interconnection facilities attached to the Company's EPS are designed, installed, operated, and maintained in accordance with all applicable codes, standards, rules, regulations, statutes, governmental ordinances, and third party permits (collectively referred to as all applicable requirements). The Customer is responsible for contacting all third parties and obtaining all applicable permits (including environmental if required), approvals and inspections, and underground facility locating services for its premises wiring installation. Documentation substantiating the completion of such activities shall be furnished to the Company upon request.

The Customer shall assume or delegate, to an authorized representative, the primary responsibility for approval and acceptance of its equipment and the timing of its installation. The Company cannot accept any responsibility for the condition of the Customer's premises wiring and equipment. The Customer is responsible for and the cost of on-going compliance with all applicable requirements noted above as well as any and all system design and operating changes to its installation.

January 2019

1.7.2 Customers served at voltages above 600 volts

1.7.2.1 Design Acceptance

The planning and design of electric service equipment at voltages above 600 volts requires skilled application of engineering principles and data to ensure proper interconnection and functionality with the utility electric supply system and to ensure safe operation and maintenance of the equipment following installation. Therefore a Professional Engineer, licensed in the state where service is made, shall prepare all documents submitted to the Company in connection with all electric service equipment above 600 volts. This requirement applies to new installations and alterations to existing installations. Designs involving alterations to existing electric service equipment shall include retrospective review of the original design to ensure the alteration will function properly.

Signature, license number, seal, or letterhead with return address, as appropriate, will suffice as evidence of preparation by a licensed PE. Documents not evidencing preparation by a licensed PE will be returned to the submitter without comment for resubmittal to the Company.

1.7.2.2 Operation and Maintenance

Customers owning electric service equipment above 600 volts shall operate and maintain such equipment in accordance with Company supplied operating instructions and NEC or NESC requirements.”

1.8 COMPANY’S RESPONSIBILITIES

The electric supply and service installation provisions and costs shall be in accordance with the Company’s filed tariffs.

These specifications are subject to revision without notice. They may be revised or amended as the Company shall determine, or as required by developments of the industry to protect the mutual interests of the Customer and Company. The latest revision shall be used. Additional copies of these specifications and any errata can be obtained from the Company; also see Section 1.5 for Company supplemental specifications.

1.9 INSPECTION, WIRING ADEQUACY, AND ENFORCEMENT

The Company requires the Customer to furnish satisfactory evidence of the safe condition of its wiring before any service is connected. This will be in the form of an electrical inspection approval certificate from the authority having jurisdiction (AHJ) or an inspection agency approved by the AHJ and the Company. Inspections shall confirm compliance with the National Electrical Code, any applicable municipal codes, and any specific utility service rules that are in addition to the aforementioned codes. The Company and its accepted inspection organizations have the authority for enforcement of these rules.

To re-energize a service that has been disconnected for an unsafe condition by any AHJ mandate or by the Company, the Customer must provide an electrical inspection certificate from an approved inspection agency to the Company prior to reconnection.

The Company requires certificates of inspection:

- On all new services and
- To re-energize any existing service that has been de-energized by any disconnect method (cutting service lateral conductors at pole or weatherhead, meter removal, etc.) for any of the reasons or durations listed below:
 1. an emergency,
 2. theft of service,
 3. duration exceeding twelve months,
 4. following 36 months of service inactivity, and
 5. when premises wiring (system) is replaced, altered or extended.

1.10 DISCLAIMER

1.10.1 Company Approval

The Company's approval of the Customer's installation constitutes the Company's acceptance of the Customer's proposed arrangement and equipment as meeting the Company's minimum requirements under these rules and does not relieve the Customer from the obligation of complying with all applicable codes, statutes, rules or regulations.

1.10.2 Use of Electricity

The Company shall not be liable for damage to the person or property of the Customer or any other persons resulting from the use of electricity or the presence of the Company's equipment on the Customer's premises.

Relative to any information supplied by the Company in connection with a customer, it must be understood that the Company's EPS is a dynamic system that changes from moment to moment as demands are made to the system. Furthermore, permanent changes to the system are common which will change the information provided to Customers or their Agents. Although the Company makes every reasonable effort to obtain reliable information and proper calculations, the Company provides no warranty, expressed or implied, as to the accuracy, reliability or completeness of data furnished to Customers or their Agents. Liberty Utilities reserves the right to make improvements, upgrades or other changes to the electric system without notice. Such changes may invalidate any information provided.

1.10.3 Condition of Service

The Company shall not be liable for, or in any way in respect of, any interruption, abnormal voltage, discontinuance, or reversal of its service, due to causes beyond its immediate control whether accident, labor difficulties, condition of fuel supply, the decision of any public authority, or failure to receive any electricity for which in any manner it has contracted, or due to the operation in accordance with good utility practice of any emergency load reduction program by the Company or one with whom it has contracted for a supply of electricity, or inability for any other reason to maintain uninterrupted and continuous service; provided, however, that under the terms of the Company's applicable tariff if the Company is unable for any of the causes enumerated above to supply electricity for a continuous period of two (2) days or more, then upon request of the Customer, the Demand Charge, if any, shall be suspended for the duration of such inability.

1.10.4 Company Warranty Statement

For all voltages and services, the Company will cooperate with its customers or their representatives. However, neither by inspection, nor by the rendering of advisory service, nor in any other way, does the Company give any warranty, expressed or implied, as to the adequacy, safety, or other characteristics of any equipment, wires, appliances, or devices owned, used, or maintained by Customers.

1.11 ENFORCEMENT OF COMPANY REQUIREMENTS

1.11.1 Enforcement Criteria

The Company and the local AHJ have the authority to enforce these specifications. The Company's Specifications for Electrical Installations Committee has the responsibility for: making interpretations of the rules, deciding upon the approval* of equipment and materials, and granting the special permissions contemplated in a number of the rules.

Alternative construction methods not covered in these specifications must be submitted to the Company in writing and be approved* by the Company prior to purchase and/or installation of equipment. The Company shall only grant deviations from these specifications in writing.

Exceptions from the NEC or other codes shall only be granted in writing by the local code authority exercising jurisdiction and filed with the Company.

***Note:** See Section 2 for the definition of the term "Company approval". The Company does not "approve" all aspects of the Customer's equipment or premises wiring installation.

1.11.2 Diversion of Electrical Energy

A diversion of electrical energy is any method or device used by any person that prevents an electric meter from duly registering the quantity of electricity supplied by the Company and/or the taking of any electrical current without the Company's consent.

Where there is evidence of meter tampering or theft of electrical energy, the responsible person or persons shall be liable for prosecution under penalty of law.

2.0 DEFINITIONS

Notes:

- (1) The following are terms defined as used in this publication.
- (2) For graphical relationship of defined components and section references in this book, see **Figure 2-1**.

Figure 2-1: Typical Service Installation Diagram Below 600 volts – Excluding Network

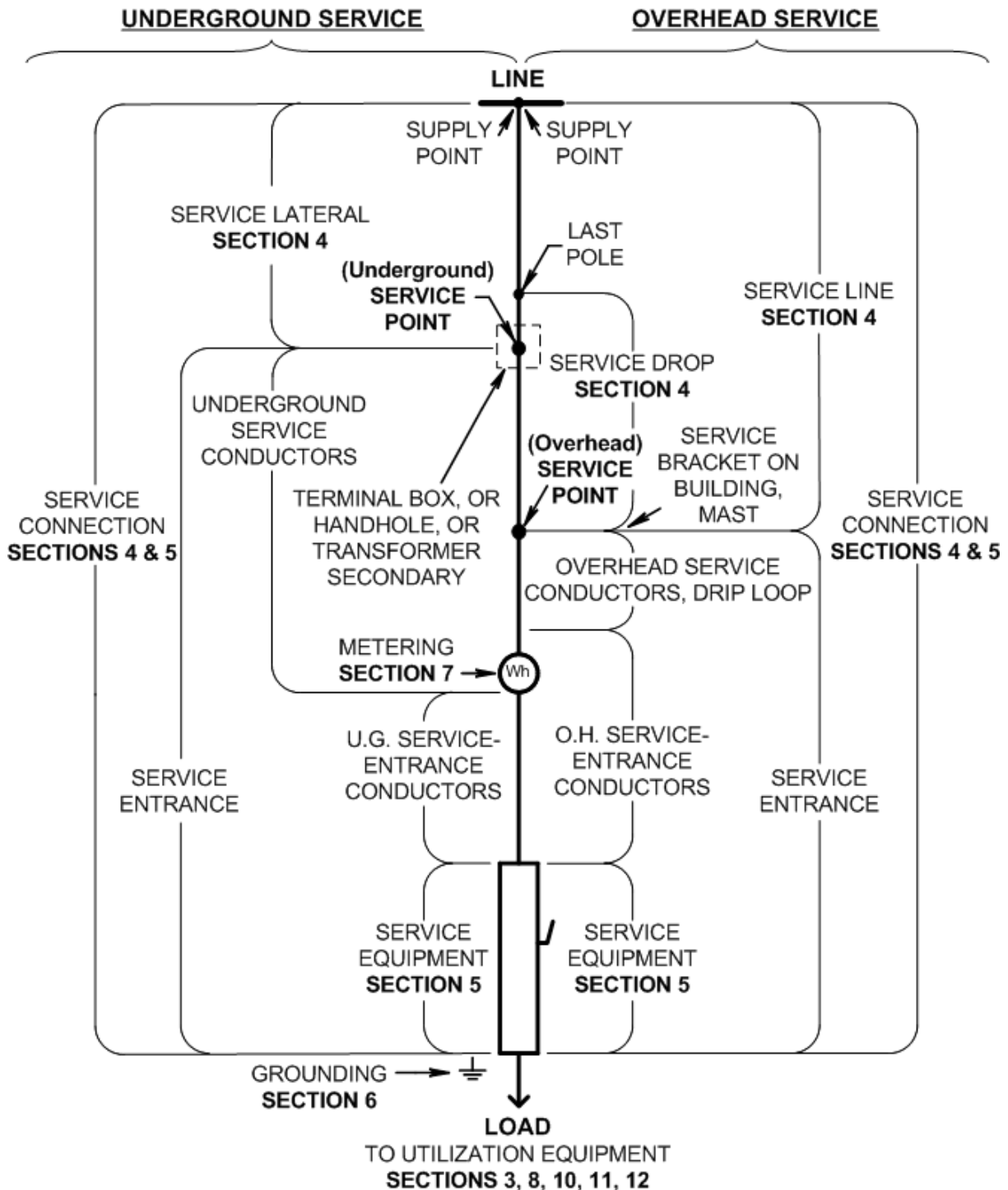

January 2019

Applicant: Any entity (individual, firm, partnership, corporation, association, municipality, or governmental body) requesting a new service from the Company for their own use and not for resale or delivery to others.

Note: The Company must be consulted for specific Applicant rules as they apply in the Company's applicable tariff.

Area Lighting (Utility): A utility lighting distribution system that provides lumens on public or private property. (See NEC 90.2(A) where area lighting is not under the exclusive control of utilities and see the NESC for information that covers area lighting under the exclusive control of utilities.)

Authority Having Jurisdiction (AHJ): Governmental bodies or their Agent exercising legal jurisdiction over applicable codes.

Back-up Service: A service type provided during an unscheduled outage of the Customer's facility, up to the portion of Customer's electrical requirements supplied by the Customer's facility.

Building: A structure which stands alone or which is cut off from adjoining structures by approved fire walls with all openings therein protected by approved fire doors.

Clearance: Required separation mandated by codes or the Company.

Cold Sequence metering: Metering equipment located on the Customer's side of the service equipment.

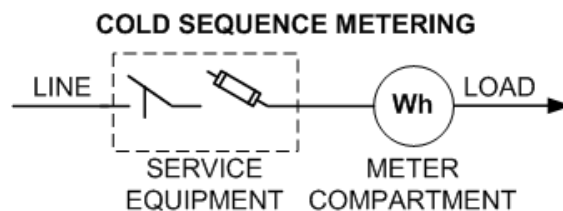

Company: Granite State Electric Company doing business as Liberty Utilities to which these requirements apply.

Company Approval: Acceptance for the minimum requirements of Liberty Utilities exclusive of the Customer's obligation of complying with all applicable codes, statutes, rules or regulations. (See 1.10.1.)

Customer: An existing user of recurring electric service. (A contractor or developer performing work on behalf of a Customer is considered an agent of the Customer.)

Seasonal Customer: A Customer who applied for and receives the Company's service periodically each year, intermittently during the year, or at other irregular intervals.

Design Professional: A Professional Engineer (PE) licensed to practice in the state where service is being installed and who is directly retained by the Customer for that purpose. (If the state licensed PE is representing a multi-member design firm, the firm shall have state certification to practice professional engineering and a copy of such license must be provided to the Company upon request. Any Company requested design professional certification proof must be submitted to the Company in writing upon initial design submission.)

Distribution Line: A distribution line is an electric line, either overhead or underground, including the necessary and ancillary accessories to distribute electric energy, which may provide service to more than one customer. A distribution line may be located (1) in a street, highway, alley, or (2) on private right-of-way when used or useful to supply two or more customers at separate premises.

Drip Loop: Individual conductors formed to prevent the entrance of moisture, and which provide adequate length to meet the Company's and applicable code requirements.

Electrical Inspector: Inspectors external to the Company who are approved by the municipality in which they are working and recognized by the Company. Electrical Inspectors are responsible for ensuring that the installation complies with all applicable codes and Company requirements, service equipment, material, installations, and/or procedures.

Electric Service: Maintenance by the Company of the appropriate voltage and frequency at the point of delivery shall constitute the delivery of electric service to the Customer. (See Service.)

Emergency: An unplanned natural or accidental event that affects existing electric service.

Emergency Power System: A system legally required and classed as emergency by codes or any governmental agency having jurisdiction that automatically provides an independent reserve source of electricity, upon failure or outage of the normal power source, to elements of a power system essential to the safety of human life.

Exclusive Control: Generally covers installation, ownership, restricted access, operation, and maintenance by qualified and authorized persons.

Fire Wall: A wall separating buildings or subdividing a building to prevent the spread of fire and having a fire resistance rating and structural stability as determined and approved in writing by the AHJ.

Hot Sequence metering: Metering equipment located on the Company's side of the service equipment.

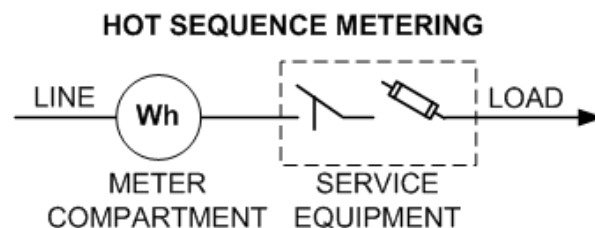

Line: A system of poles, conduit, wires, cables, transformers, fixtures and accessory equipment used for the distribution of electricity to the public. A line may be located: (1) in a street, highway, alley; or (2) on a private right-of-way when used or useful to supply two or more customers at separate premises.

Maintenance Service: A scheduled service for the Company to perform maintenance on the Customer's equipment, during a Customer's planned outage. Such service shall be pursuant to written agreement and, normally, scheduled at least one month in advance with the Company.

Manufactured Home: A factory assembled structure or structures transportable and designed to be used as a dwelling unit with a permanent foundation acceptable to the local AHJ.

Mobile Home: A factory assembled structure or structures transportable on their own running gear and designed to be used as a dwelling unit(s) without a permanent foundation.

Multiple Residential Occupancy Building: A structure, including row houses, enclosed within exterior walls or fire walls, which is built, erected and framed of component structural parts and is designed to contain four or more individual dwelling units for permanent residential occupancy.

Point of Attachment: The location of the service drop conductors to a building or structure provided by the Customer and installed to maintain clearances specified by the NEC (Article 230) and by the Company's requirements. (Service conductors are supported by mechanical attachment to the building or structure.)

Premise: A premise is a unified, undivided parcel of real property under the Customer or Applicant's control through ownership or lease which is not separated by a public road, right of way, or property belonging to another entity. A premise may or may not contain buildings or structures within the real property.

Premises: The land and buildings of the Customer located on the Customer's side of the service point.

January 2019

Primary: The Company's distribution systems typically operating over 600 volts.

Recreational Vehicle: A vehicular type unit primarily designed as temporary living quarters for recreational, camping, or travel use, which either has its own motive power or is mounted on or drawn by another vehicle. These include: travel trailer, camping trailer, truck camper, and motor home.

Recreational Vehicle Park: Sometimes called "Trailer Park", is an accommodation for Recreational Vehicles where individual site occupancy is normally of short duration.

Restricted Access by the Company. Areas where exclusive control by the Company is maintained.

Secondary: The Company's distribution systems typically operating at 600 volts or below.

Separately Derived System: A premises wiring system whose power is derived from another source of electricity and that has no direct electrical connection, including a solidly connected grounded circuit conductor, to the service.

Service: The conductors and equipment for delivering energy from the Company's distribution line to the wiring system of the Customer served. (See Electric Service.)

Residential Service: Service to one or more dwelling unit(s) providing complete and independent living facilities for one or more persons and which include permanent provisions for sleeping, cooking, and sanitation.

Non-Residential Service: All service types other than residential.

Service conductors: The conductors from the service point to the service equipment of the Customer supplied by the Company.

Overhead Service Conductors: The overhead conductors between the service point and the first point of connection to the service-entrance conductors at the building or other structure.

Underground Service Conductors: The underground conductors between the service point and the first point of connection to the service-entrance conductors in a terminal box, meter, or other enclosure, inside or outside the building wall. As of 01/2019, the *Company* will install, own, and maintain all new installed Residential Underground Services – See Appendix 4

Service connection: One service lateral or service line and its associated service entrance.

Service drop: The overhead conductors between the last pole or other aerial support of the Company's electric supply line up to and including the splices connecting to the service point's service entrance conductors at the building or other structure.

Service entrance: That part of the Customer's wiring from the point of attachment or termination of the service lateral or service line to and including the service equipment.

Service entrance conductors: The wires or cables between the service conductors and the service equipment.

Overhead System Service-Entrance Conductors: The service conductors between the terminals of the service equipment and a point usually outside the building, clear of building walls, where joined by tap or splice to the service drop or overhead service conductors.

Underground System Service-Entrance Conductors: The service conductors between the terminals of the service equipment and the point of connection to the service lateral or underground service conductors. (Where service equipment is located outside the building walls, there may be no service-entrance conductors or they may be entirely outside the building.)

Service equipment: The Customer's necessary disconnecting and protective equipment intended to constitute the main control and cutoff of the supply from the service point. This consists of a circuit breaker(s) or switch(es) and fuse(s) and their accessories connected to the load end of service conductors. The service overcurrent device shall be an integral part of the service disconnecting means or shall be located immediately adjacent thereto.

January 2019

Service Head: For cable in conduit risers, a service head is one that is raintight and listed for the purpose for preventing water from entering service entrance conductors, raceway, or equipment.

Service line or lateral: The Company's electric line including the necessary and ancillary accessories to connect a distribution line to an individual customer's meter or point of attachment. (A service line or service lateral, at the Company's discretion, may be connected to two or more meters at a single premise. Wiring along the outside of the Customer's house or building shall not be included in the service line or service lateral.)

Service line: The overhead conductors between the utility electric supply system and the service point. (A service line does include a service drop.)

Service lateral: The underground conductors between the utility electric supply system and the service point.

Service Point: The point of connection between the facilities of the Company and the Customer's premises wiring. (The service point can be described as the point of demarcation between where the serving utility ends and the premises wiring begins. The serving utility generally specifies the location of the service point based on their conditions of service. Refer to Figures 1.5-1 and 2-1.)

Service Riser Mast: A rigid metal conduit containing service entrance conductors that supports the service drop to maintain required vertical clearance.

Service Riser Pole: The Company's pole where the Customer's underground service conductors emerge to connect to the Company's overhead distribution line or transformer.

Shall: The word "shall" indicates provisions that are mandatory.

Short-term service: A service that is recurrently required only for short periods each time, either periodically each year, intermittently during the year, or at other irregular intervals.

Standby Power System: An alternate source of electricity incorporating necessary transfer equipment intended to supply power to selected loads upon loss of the normal power supply.

Supervised Installation: Conditions of maintenance and supervision ensure that only qualified persons monitor and service the system continuously provided by a single building management.

Supplemental Service: A service type provided to meet the Customer's electrical requirements in excess of on-site generation.

Supply Point: The point of connection of the Company's service lateral or service line and the facilities of the Company.

Temporary Service: A non-recurring service intended to be used for a short time only, not to exceed one year for residential or two years for commercial applications. (Temporary service can be to a non-permanent structure or personal property, or to a building or structure which is non-permanent in that it may be readily removed or relocated, or as a preliminary connection toward the establishment of permanent service.)

Underground Commercial Distribution (UCD): An underground electrical supply system using at-grade transformers and switchgear to serve commercial or industrial customers.

Underground Residential Distribution (URD): An underground electrical supply system using at-grade transformers and switchgear to serve five or more residential customers.

Utilization Equipment: An electrical installation that uses electric or light energy for electronic, electromechanical, chemical, heating, lighting, testing, communication, signaling, or similar purposes on the premises wiring side of the service point. (Performed under the NEC.)

Weatherhead: A weatherhead for service entrance cable installations is a manufactured raintight service head listed for the purpose as permitted according to the NEC.

3.0 GENERAL SERVICE CONNECTION REQUIREMENTS

3.1 APPLICATION FOR SERVICE

3.1.1 Application

Application for a new or changed service may ordinarily be made by mail, facsimile, telephone call to the Company, or by means of the Company's Internet Web site. Refer to the "Process and Information" section at the beginning of this book. Written application will be required when a service is taken from a line extension or when otherwise mandated by the provisions of the applicable tariff.

An applicant must make a separate application for each point of delivery and metering point, and for each class of service desired. That is, for each separate residence, apartment, business, building, structure, or premise where electric service is desired, a separate application is required. The Company will extend facilities to "premises" specifically identified on municipal tax maps.

Application should be made as far as possible in advance of the date the new or changed service is required to assure time for engineering, ordering of material, and construction. Delivery of equipment, depending on size and voltage rating, may take considerable time. A plot plan designating the location of buildings or additions should be provided with new electric load data.

3.1.2 Public grants and special permits

In many cases, public grants or special permits must be obtained by the Company from the local governmental authority where it is required that a service be run over, under, or along a public way. In some instances these grants and permits can be obtained only after public hearings are held. In such cases, delays in service connections can be avoided or curtailed by applying to the Company for service at the earliest possible date.

3.1.3 Easements

As a condition of service, the Applicant or Customer must provide the Company with an easement(s), properly executed by all owners of record drafted by the Company, for all Company owned facilities located on private property (to include Private Ways), whether or not such private property is owned by the Customer. The Applicant or Customer will provide such easement(s) prior to the start of the Company's construction and at no cost to the Company. The Applicant or Customer shall provide a copy of its mortgage and deed, together with a copy of the survey and/or plan of record, for the Company's use in preparation of the easement(s) as well as any other documents necessary for the Company to prepare such easement(s).

3.2 NUMBER OF SERVICES

3.2.1 With Respect to Building and Premise

One alternating current service will normally be installed to a building or structure on a premise.

3.2.2 Electricity Delivered Through More Than One Meter

Where electricity is delivered through more than one meter, the cost of service delivered through each meter will be computed separately.

January 2019

3.2.3 Multiple Service Requests

Multiple service requests, by their nature, often impose complex issues with respect to state laws and the Company's obligations. For these requests the concepts of premise, building, and necessity, need to be evaluated individually. These key considerations require a prospective Customer contemplating such a multiple service request to contact the Company prior to proceeding with either a formal electric service request or project plans assuming such an arrangement. Even if approved by the AHJ, the Company will make the final determination as to whether multiple services will be permitted. To aid in the assessment of the above items, the Customer shall provide written documentation from the local AHJ over building and electrical codes indicating that the building or structure under consideration is approved by the AHJ for a multiple electric service arrangement. At a minimum, the AHJ's written approval shall state suitability in accordance with all provisions in effect of the applicable Fire Prevention and Building Code and National Electrical Code including local ordinances.

When the above documentation has been received and the Company approves of a multiple electric service arrangement, the Company will provide specific requirements for each service point. The Company recommends the Customer consult its building insurance carrier regarding the potential liabilities associated with specific multiple service point proposals.

In addition, as required by the Company's applicable tariff, the Customer shall reimburse the Company for any distribution facilities requested for the Customer's convenience that the Company deems to be over and beyond what is necessary in order to provide service to the Customer. The Company is under no obligation, however, to provide such facilities. Mutual agreement is required between the Customer and the Company. The Company will provide estimates for any cost contribution required for providing additional service(s) in accordance with its applicable tariff. A construction advance may be required. If a Customer desires more than one service in order to separately meter another building on the same premise, and if this building could otherwise be supplied through the one meter and if the Company allows such additional service, the Customer shall pay the entire cost of installing the additional service according to the Company's applicable tariff.

3.3 TEMPORARY SERVICE

3.3.1 Company Facilities

Temporary service facilities may include a line extension, a service lateral, installation of transformers, meter facilities, and other work by the Company. Examples of temporary service are those supplied to non-permanent structures, during the construction of permanent structures or projects, or for short-term service to carnivals, exhibits, decorative lighting, etc. Customer installations considered unsafe by the Company will not be energized. Temporary service installations require an AHJ approval.

3.3.2 Location

The temporary structure shall, whenever possible, be located adjacent to the permanent building so that the service may be transferred to the point of permanent attachment when the construction is completed. Typical overhead and underground temporary services are shown in Section 4.

3.3.3 Equipment

Service entrance, meter and other wiring on temporary installations are to be installed in the same manner as required for permanent installation with respect to service-drop clearances, metering, grounding, and safety. Service entrance equipment shall be installed on a structure; see Sections 4 and 5. Inspections and approval by an authorized inspection organization shall be required prior to the Company making the service connection. The Customer shall be required to provide a substantial and adequate support, guyed if necessary.

January 2019

3.3.4 Duration

Temporary service shall be permitted for holiday decorative lighting, carnivals, and for similar purposes for the ninety (90) day period permitted by the NEC. Temporary service for residential home construction shall be permitted for a period not to exceed one (1) year or two (2) years for commercial construction depending upon the applicable Company tariff.

When temporary service is a result of an emergency, the permanent service shall be re-certified according to these specifications by an authorized NEC inspector within five (5) business days.

3.3.5 Cost

In accordance with the Company's applicable tariff, the Customer may be required to pay in advance the estimated cost of installing and removing the temporary service. Estimates of the cost for temporary service to commercial and industrial installations may be obtained from the Company's Electric Service Representative. If any such installation presents unusual difficulties as to metering the service supplied, the Company may estimate consumption for purposes of applying the rates as set forth in the applicable Company tariff.

3.4 ACCESS

In accepting service, the Customer grants to identified Company employees and agents the right of personnel, vehicle, and equipment access to the Customer's premises at all reasonable times for such purposes as the reading of meters, inspection of meters, and installing, operating, maintaining, disconnecting and removing, any or all of the property belonging to the Company. Such access shall be suitable for its intended purpose.

When the Company's conductors supply a building or structure, these conductors shall not pass beneath or through the interior of another building or structure. Any Customer building or structure shall not encroach on the Company's line conductors and line equipment, except where transformer vaults are installed within the building served.

The Company may discontinue service after reasonable notice, if access to its meters or other equipment is unreasonably refused, obstructed, or hazardous. The Customer may also be assessed a charge if access is prevented or hindered.

3.5 IDENTIFICATION OF EMPLOYEES

Employees of the Company, or its agents, authorized to visit the premises of its Customers, are furnished with photographic Company identification, which they will show upon request.

3.6 CHARACTER OF SERVICE

The Customer shall inquire of the Company as to the type of service to be supplied prior to the purchase of electrical equipment or before proceeding with its wiring installation. In response to such inquiry, the Company will designate the type of service and delivery voltage based on the location of the Customer and the size and character of its proposed load. Special consideration will be given to the selection of the type of service to supply electric motors, furnaces, welders, x-ray apparatus and other loads, which may interfere with satisfactory service to other customers. Normally only one service is provided to a premise. For multiple services to a building see Section 3.2.

3.7 VOLTAGES AVAILABLE

3.7.1 Available Services

All new services will be 60 Hertz, single phase or three phase alternating current designated by the Company. The following types of service in Table 3.7.1-1 are generally standard but not all types are available at all locations. To find which are available, please consult the Company. This must be done before any wiring is installed or equipment purchased.

To serve residential, commercial and industrial loads, **one** of the voltage services 600 volts and less, listed in Table 3.7.1-1, will be supplied at the Company's designation.

Table 3.7.1-1 - Available Services Below 600 volts

Phases	Wires	Company's Delivery Voltage (volts)	Company's Typical Voltage Delivery Levels		Note
			Minimum Customer Load (kVA)	Maximum Customer Load (kVA)	
1	3	120/240	None	100	1.
1	3	120/208	None	20	2.
1	3	277/480	None	50	3.
3	4	208 wye/120	None	300	4.
3	4	208 wye/120	None	1000	
3	4	480 wye/277	None	500	4.
3	4	480 wye/277	None	2500	5.

Notes to Table 3.7.1-1:

1. Single-phase, 120/240 volt service is limited to 50 kVA maximum where utilization equipment includes individual motors not over 6-1/2 HP. Self-contained meter socket applications are limited to 72kW demand.
2. Where the present service is three phase, 4 wire, 208 wye/120 volts.
3. Where the present service is three phase, 4 wire, 480 wye/277 volts. Three-phase, 4 wire, 480 wye/277 volts is Commercial and Industrial use only.
4. Where supplied by cluster mounted overhead transformers at the Company's discretion; see Section 9.2.1. Demand of 150kVA or more is generally preferred to be supplied by a pad mounted transformer service. Three-phase service normally will not be made available for a residence.
5. With the exception of network service, transformer vault services are limited to 1500 kVA at 480 wye/277 volts.

For both new applicants and existing customers, the Applicant or Customer shall submit a **written** request that includes its proposed in-service date, connected load, diversified demand, and load factor information. Refer to the "Process and Information" section at the beginning of this book. Customers having the potential to exceed 75 kVA of transformer capacity may be required to supply space for electrical equipment on private property in accordance with the Company's Terms and Conditions; see Sections 4 and 9. Where three-phase secondary service is requested and available and the minimum Customer load is less than 50 kVA, the Customer may be required to contribute to the supply facilities' installation cost according to the Company's tariff in the specific service area.

For service above 600 volts, the Company will solely designate the type of service based on the location of the Applicant or Customer and the size and character of the proposed load. Please consult the Company early in the planning process to determine the specified delivery voltage

3.7.2 New Customers (Applicants)

The delivery voltage for service to a new Customer is determined based on engineering considerations such as system loading, location of electric supplies, reliability, circuit protection and coordination, planning, operation and maintenance.

January 2019

3.7.3 Existing Customers

3.7.3.1 Customer Expansion

The new delivery voltage for service to an existing Customer contemplating an expansion that will result in a maximum customer peak demand greater than the limit specified in Table 3.7.1-1, is determined based on engineering considerations such as system loading, location of electric supplies, reliability, circuit protection and coordination, planning, operation and maintenance. The Customer shall reimburse the Company as set forth in the applicable Company tariff.

3.7.3.2 Voltage Migration at Customer's Request

Voltage migration may be permitted upon written request to the Company, provided: (1) such increase in delivery voltage shall be allowed only when in the Company's sole judgment, system or facility loading, reliability and safety will not be jeopardized; and (2) the provisions of the Company's applicable tariff shall apply to any such increase in delivery voltage requested by the Customer.

3.7.3.3 Voltage Migration at Company's Request

When, in the Company's sole judgment, and consistent with the Company's applicable tariffs, the Company determines that changes in delivery voltage are necessary to alleviate system or facility loading, reliability or safety problems, the Company will make such changes and will be responsible for the associated costs.

3.8 SERVICES NO LONGER STANDARD

Non-standard services include, but are not limited to: 25 Hertz, 2 phase systems, 2 wire 120 volts, 240 volts delta, 460 volts wye, 480 volts delta, 600 volts delta, 2400 volts, 4160 volts or 4800 volts services. While 2400 volts, 4160 volts, or 4800 volts are no longer standard, they may still be available at certain locations; consult the Company.

Customers now receiving non-standard service shall not expand the use of such service, except in very limited circumstances at the sole discretion of the Company.

Customers with an existing non-standard service requesting a service change shall consult with the Company to obtain a standard single or three phase 60 Hertz service at an appropriate delivery voltage.

3.9 LOAD BALANCE

The Customer, in taking electric service, shall connect its lighting and other loads so as to maintain as nearly as is reasonably possible, equal current in each of the line conductors at the point of delivery. Voltage unbalance resulting from unbalanced currents shall not exceed 2% or shall not cause objectionable effects upon or interference with the operation of the Company's facilities and service to others. The Company may require the Customer to install any necessary operating and safety equipment in accordance with the requirements and specifications of the Company, provided such installation does not conflict with applicable electrical codes, federal, state or municipal law. The Customer is responsible for bearing the cost of any changes necessary to correct an unbalanced load condition.

3.10 INCREASE IN SERVICE

Company facilities are normally designed to meet the Customer's initial electric demand requirements at the time service is installed. The Customer shall provide the Company reasonable advance written notice of any proposed increase in service required. This notice shall include the amount and character of the proposed increased service, including the timing, frequency, and duration of the peak load, as well as the date the increased load will be required. Load increases requiring changes to the supply facilities (other than metering equipment) for the sole use of the Customer may require a contribution to the Company in accordance with the Company's applicable tariff. See previous Section 3.7. The Customer shall not make additions unless the Company has notified the Customer that it can supply the increased load.

3.11 UNAUTHORIZED ATTACHMENTS

The Company forbids any unauthorized attachments to its poles and towers, such as banners, signs, clothes lines, antennas, basketball hoops, lighting fixtures, etc. It forbids the use of any of its facilities for placards or other advertising materials. The Company will remove any such unauthorized attachments without notice and may prosecute such trespassing.

The Company forbids any work by contractors on or in any of its facilities without prior written authorization by the Company.

The attachment of antenna systems to Customer-owned electric service masts or poles carrying the Company's conductors is strictly prohibited due to the possibility of serious results from accidental contacts. Such attachments will be removed immediately upon discovery by the Company, and the removal will be at the Customer's expense.

3.12 DISCONTINUANCE OF SERVICE

The Company may discontinue service where the Customer's equipment or its operation is deemed to be unsafe or results in objectionable effects on the operation of the Company's facilities or its other customers, consistent with the procedures set forth in the Company's applicable tariff. Reconnection of service will occur after the Customer has made the required corrections at its cost. See also Section 10.

Part B – “Electric Service Requirements”

4.0 SERVICE CONNECTIONS

4.1 GENERAL

Types of Service Connections

The Company offers the following service connections, depending on the Customer’s location, character of service, and expected electrical demand:

- Overhead Secondary Voltage Service Connection (Under 600V)
- Overhead Primary Voltage Service Connection (from 2.4kV to 15kV inclusive)
- Underground Secondary Voltage Service Connection (Under 600V)
- Underground Primary Voltage Service Connection (from 2.4kV to 15kV inclusive)

Definitions to be familiar with from Section 2:

Line	Primary
Emergency System	Service Point
Multiple Residential Occupancy Building	Supply Point
Service Connection	Service Equipment
Service Drop	Temporary Service
Service Lateral	URD
Service Line	UCD

4.1.1 Rights-of-Way, Easements

See Section 3.1.3 for property rights as a condition of service.

In UCD, URD, or multiple occupancy building applications, the Customer shall provide the Company with two copies of the approved development map, certified as final by a design professional or licensed land surveyor, which the plan shall have been recorded or filed with the Registry of Deeds. The map shall indicate lot lines, building setback lines, grade lines, sidewalk, roadway, sewer, water, drainage, and other facilities. The map shall also include the identification and, where appropriate, delineation of sensitive environmental resources including, but not limited to, wetlands, streams, archaeologically sensitive areas, and hazardous waste disposal areas, etc. In addition to this base information, this map shall clearly indicate the easement strips dedicated to the Company and the location of the lots (units) for which electric service is requested. The governmental authority having control over land use shall approve this map. In addition, when electronic maps are used, the Customer must consult the Company for submittal.

Rights-of-way and easements must be cleared of any obstructions at no charge to the Company. The applicant shall grade the right-of-way or easement to within six inches (150 mm) of final grade before the Company commences construction. The applicant must maintain the Company’s clearance and grading requirements.

4.1.2 Number, Routing and Location of Service Laterals or Service Lines

The Company will designate the number of service laterals or service lines required to provide service to a Customer. Normally, the Company runs only one service lateral or service line to a Customer. Service laterals or service lines will not be run from building to building. The Company will designate the location from which the service will be taken, the type of construction to be employed, the routing of the service lateral or service line, and the service point location. The Company will consider appearance, accessibility, available right-of-way, and the desires of the Customer in making this decision.

January 2019

4.1.3 Relocation of Service Laterals

When electric service relocation is at the request of the Customer, all costs associated with the relocation of the service lateral on both private and public land shall be borne by the Customer.

When the service lateral relocation is the result of an order by a public authority, the Customer shall pay for that portion of the cost associated with the service lateral movement on private property. In some instances, the public authority may compensate the Customer for this expense.

When the pole from which a customer-owned underground service lateral originates must be replaced it is the Customer's responsibility to move its service lateral to the new pole location at its sole expense.

For a customer-owned electric service lateral needing relocation, it is the Customer's responsibility to arrange with its contractor to move its service lateral. This responsibility includes coordination of this relocation with the Company and inspection of the newly relocated service lateral by an authorized electrical inspector.

Company-owned facilities involved with any relocation will be the responsibility of the Company.

4.1.4 Allowable Voltage Drop

The Company recommends that the Customer's conductors from the service point to the main service equipment (see Figure 2-1) be sized to limit voltage drop to 1%. Normally, the Company's voltage range measured at the service point for service below 600 volts is between 114 volts and 126 volts within the Company's service territory. Refer to 10.8 Voltage Tolerance Boundary for additional guidelines. It is the Customer's responsibility to maintain adequate voltage beyond the service point.

4.1.5 Minimum Size-Single Phase Service Connections

A new single-phase service connection for an installation of one meter shall have a current carrying capacity of not less than 100 amperes, and for an installation of more than one meter not less than 150 amperes. The Company, in its sole discretion may also allow non-dwelling type installations such as, but not limited to CATV equipment, signs, and service to traffic control systems to be a minimum of 30 amperes. The Company may grant an exception in writing if the Company determines adequate service facilities are assured. The Company recommends ampere capacities greater than the National Electrical Code's required minimum, when significant future load increases are expected.

4.1.6 Service Conductor Splicing

Service conductors may be spliced in accordance with the National Electrical Code (NEC) except for the following situations:

- above grade on Company pole unless in the supply space at transformer by Company,
- within meter socket enclosure,
- within conduits on pole, and
- inside of a building unless approved by the NEC.

Where extensions within a secondary transformer compartment or within a Customer vault are necessary, splicing is done by either the Company or the Customer depending on the application: for single-phase pad-mounted transformers, splicing is done by the Company; for three-phase pad-mounted transformers and vault installations, splicing is done by the Customer.

4.1.7 Routing of Metered and Unmetered Conductors

Metered and unmetered conductors of any voltage shall not be installed in the same raceway, auxiliary gutters and/or pull boxes. Where unmetered conductors are run through the Customer's premises, they shall be enclosed in a continuous run of (threaded) rigid metal conduit with no conduit bodies, or in service busway, or in concrete-encased ductline (which may be required by the AHJ for certain situations). The installation of pull boxes or other similar devices is only permitted on unmetered raceways on the Customer's premises with the Company's written approval.

Where unmetered plug-in type armor-clad busway is used to serve customers in the same building, all plug-in access openings shall be provided with a steel hasp assembly for the Company's padlocking of the hinged hood in the closed position.

The sealing of unmetered raceways with lead-wire or padlock type meter seals is not permitted by the Company.

4.1.8 Inhibiting Grease

Caution: Inhibiting grease shall not be applied on meter socket jaws or meter blades.

4.1.9 Electric and Gas Meter Clearances

Electric meters for newly installed services shall be located outdoors, unless permitted by the Company in certain limited circumstances. Electric meters shall not be located above or below gas regulating vents and must maintain a minimum 36" horizontal distance from a gas regulating vent. In all cases, the Gas Service Provider shall be consulted regarding the location of gas meters near electric meters or electrical equipment.

Figure 4.1.9-1 Electric Meter to Gas Meter Clearances

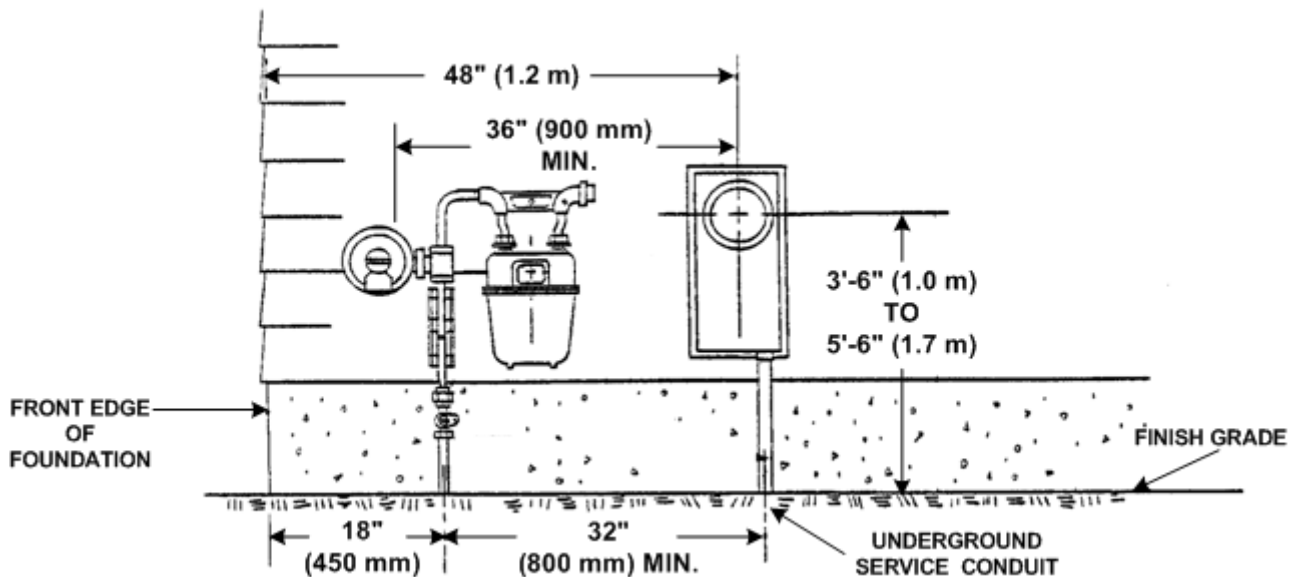

4.1.10 Temporary Service

Temporary service may include the installation of a line extension, service lateral or service line, setting meters or other extra work by the Company. The Customer may be required to pay, in advance, the entire cost of the temporary service including removal of the temporary service; see Section 3.3.

Temporary service is generally provided as an overhead secondary service voltage connection. The Customer will provide, as the point of attachment, either:

- A properly guyed wood pole or a building on which the service bracket can be attached. The wood pole shall be ANSI Class 3 minimum, pressure treated and of sufficient height to provide proper ground clearance for conductors. This installed pole shall be safe for climbing. Where a 25 ft. (7.5 m) pole is permitted, a 5 ft. (1.5 m) minimum burial depth is required. Installations determined to be unsafe by the Company shall not be energized. The span for the service drop shall not exceed 150 feet (45 m). Temporary service drops shall not be attached to construction trailers. This arrangement is shown in Figure 4.1.10-1

January 2019

Figure 4.1.10-1 Typical Overhead Service Pole for Permanent or Temporary Service Below 600V

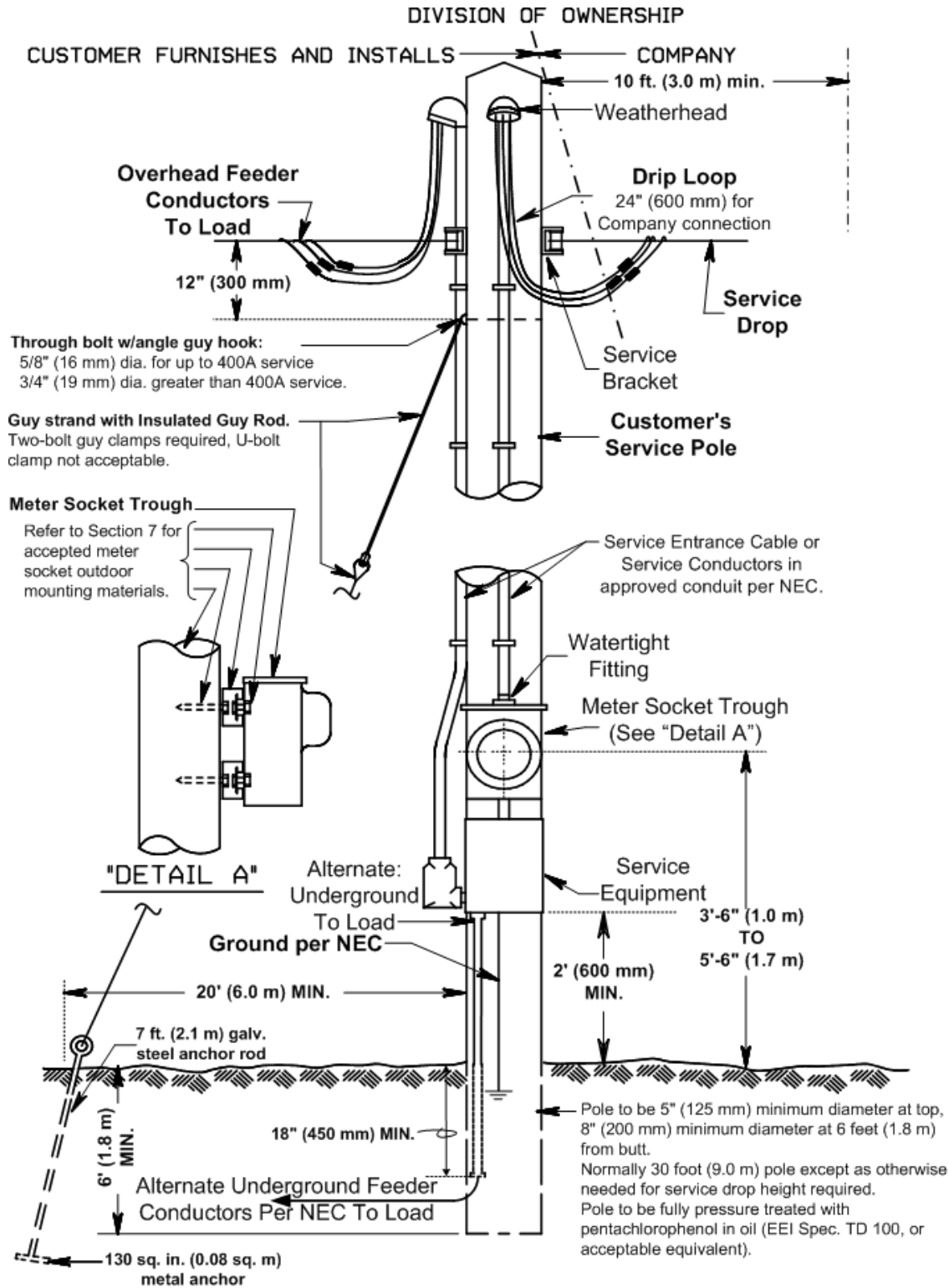

- For an alternate temporary overhead service arrangement, a 6" (150 mm) X 6" (150 mm) foundation grade treated post with cross bracing as shown in Figure 4.1.10-2 below may be permitted.

January 2019

Figure 4.1.10-2 Temporary Overhead Service Below 600 volts

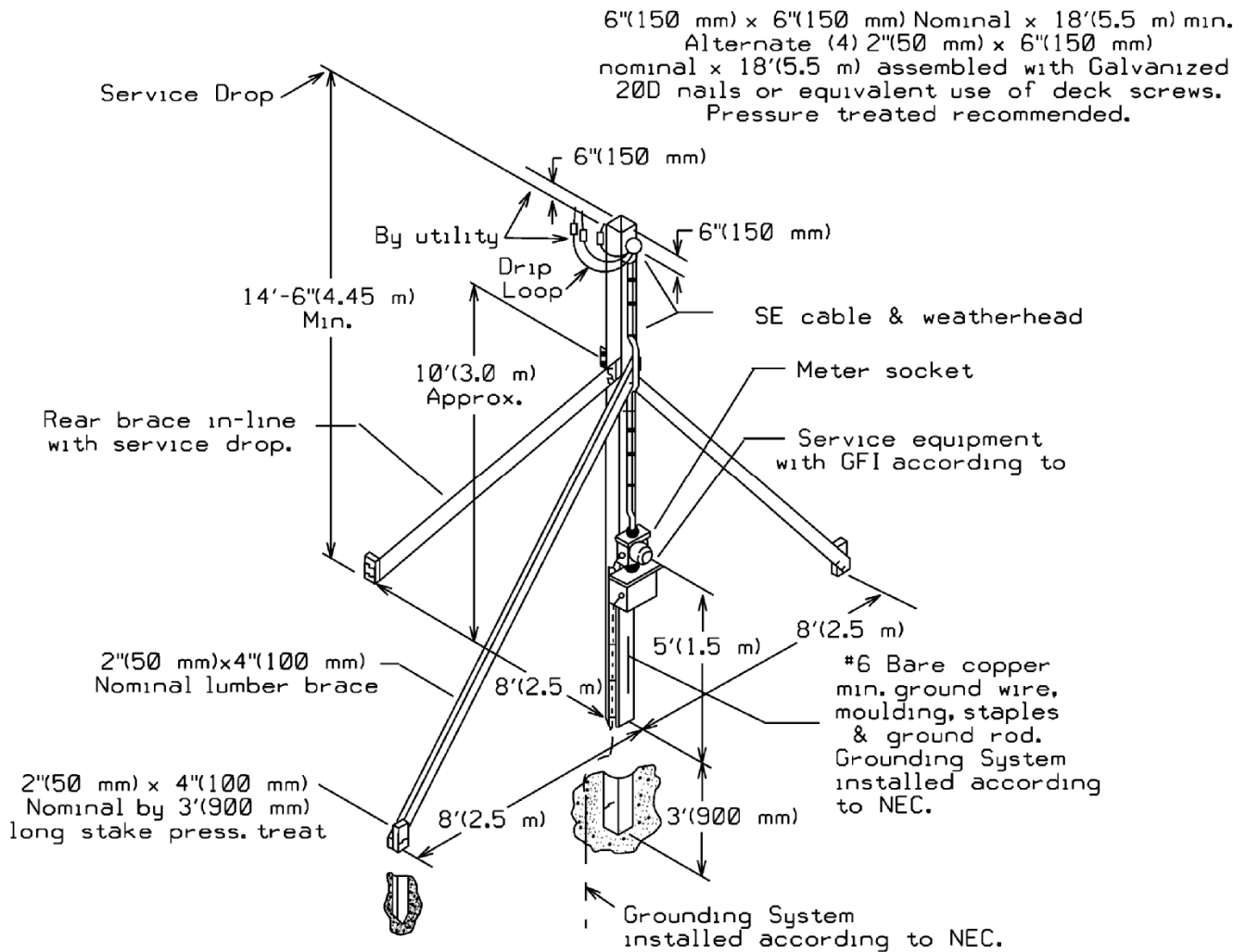

- In general, this type of temporary structure should be used for same side of street service drops. Clearance over access ways will need to meet NESC clearances. See section 4.2.4 Overhead service line clearances.
- Where conditions permit, an underground temporary service may also be obtained as shown in Figure 4.1.10-3 below.

January 2019

Figure 4.1.10-3 Temporary Underground Service Below 600 volts

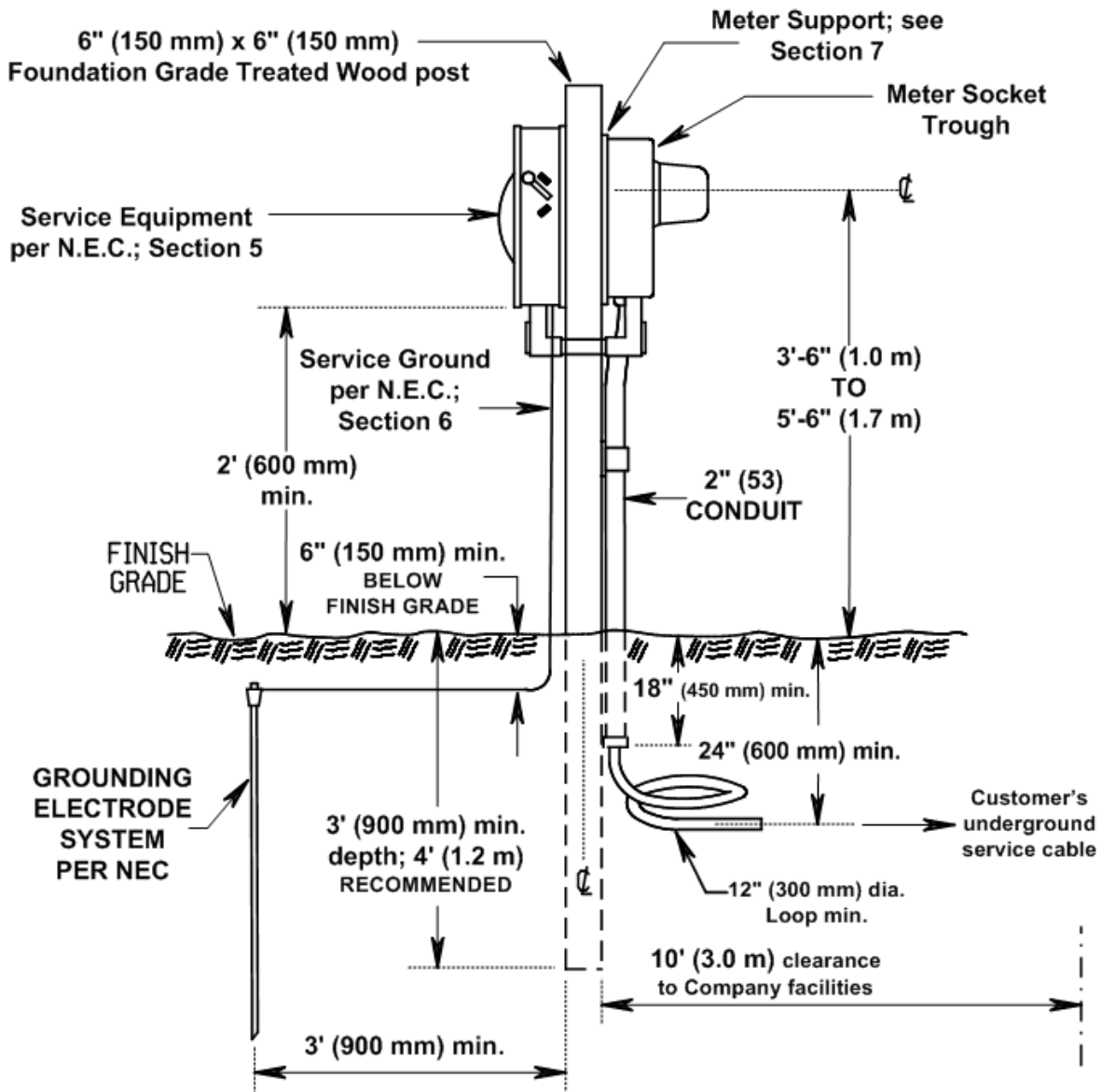

4.1.11 Fire Alarm and Emergency Systems

4.1.11.1 Fire Alarms

All fire alarm circuits shall be metered. If the authority having jurisdiction requires that the fire alarm service connection be ahead of the normal metering, then a second meter for the fire alarm shall be installed. Where self-contained meter sockets are applied, the meter socket provided by the Customer shall be equipped with a lever bypass. The Customer shall pay the entire cost of metering the fire alarm service.

4.1.11.2 Emergency Systems

Emergency systems may be served through the building's main service equipment or through separate main service equipment and separate metering, tapped ahead of the building's main service equipment. Due to NEC requirements for the continuous duty of emergency systems, these systems shall be instrument transformer metered only, and shall not be metered by self-contained meters. The Customer shall consult with the AHJ regarding specific requirements for emergency systems. The Customer shall pay the entire cost of separately metering the emergency system service.

4.1.12 Service to Manufactured and Mobile Homes, Mobile Home Parks, and Recreational Vehicle Parks

The provision of electric service to these types of structures present challenges to the Company and the Customer because general service drops and underground service laterals cannot be placed directly on the structure itself, but rather, must be metered and served through a remote meter assembly (meter pedestal or Customer service pole) and service equipment.

4.1.12.1 Service to Manufactured and Mobile Homes and Mobile Home Parks

Mobile home parks of certain sizes (number of lots) and within various locations may require the Company to comply with Underground Residential Development (URD) rules. These rules may differ by state. The Customer or Developer is urged to contact the Company prior to planning electric service to a new or expanding mobile home park to discuss the specific arrangements necessary to provide electric service consistent with the Company’s applicable tariff.

When the Company determines that overhead service shall serve a single manufactured or mobile home, the Customer shall install a Customer service pole, as shown in Figure 4.1.10-1. When the Company determines that underground service shall serve a single manufactured or mobile home, the Customer shall install a service post shown in Figure 4.1.10-3 or meter pedestal as shown in Figure 7.3-8.

Depending on the arrangement and number of manufactured or mobile homes to be served, a meter board may be installed as shown in Figure 4.1.12.1-1 below and in Figure 7.3-10. This arrangement allows a number of metered manufactured/mobile homes to be served from the same service point, and to be metered in the same location. The Customer/Developer is cautioned to comply with the necessary load calculations as described within the National Electrical Code and to comply with the requirements as set forth by the local AHJ.

Figure 4.1.12.1-1 Typical Overhead Service Installation for Mobile Home Park

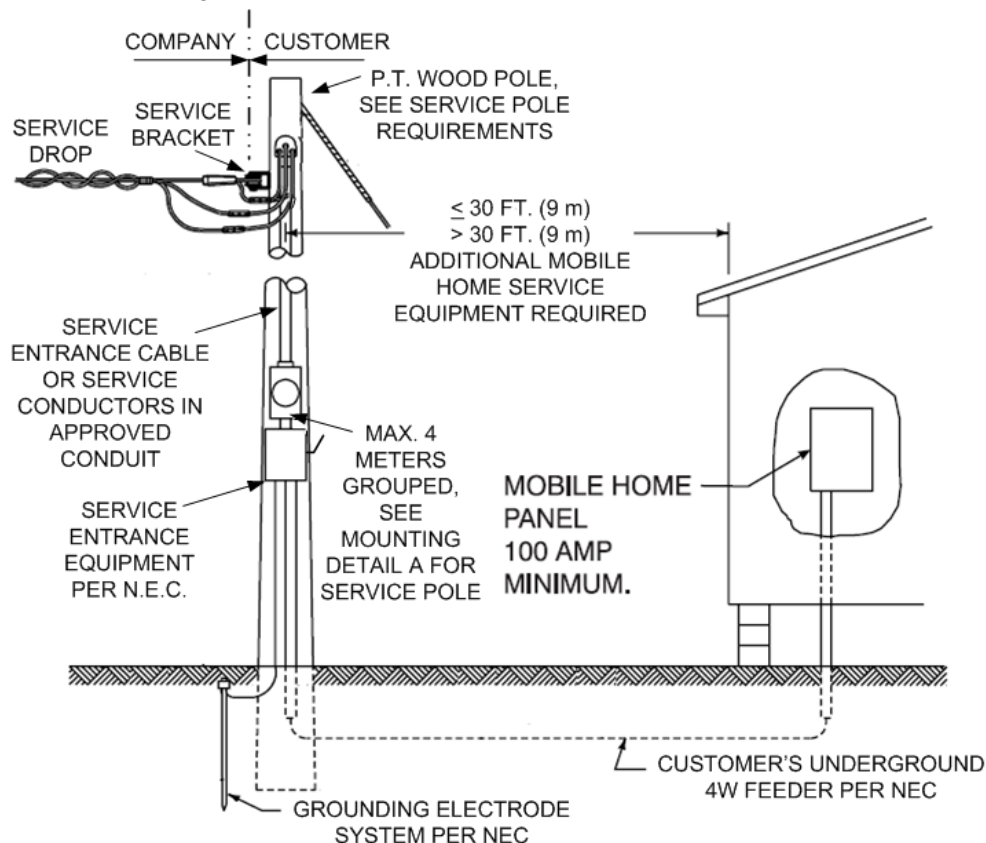

4.1.12.2 Service to Recreational Vehicle Parks

Electric service to Recreational Vehicle Parks shall be provided through one single service lateral or service line and one or more meters at a single location. Individual lots shall not be separately metered. The Customer/Developer shall comply with the NEC requirements regarding the distribution of its own electric service throughout the park. The Customer/Developer shall contact the Company regarding “Seasonal”, “Temporary” or “Permanent” service types. See Section 2 for definitions and Section 3.3 for short-term and temporary service requirements.

4.2 OVERHEAD SECONDARY VOLTAGE SERVICE CONNECTION (UNDER 600V)

4.2.1 General

An example of a typical Company-provided secondary voltage overhead service is shown in Figure 4.2.1-1 below. The Company will **construct, own and maintain all overhead service lines (service drop)**, that is, that portion of the supply circuit between the Company’s secondary distribution line serving other customers and the service point in accordance with the Company’s applicable tariff. Refer to Section 2 for the definition of the term service line.

An overhead service drop may be provided to supply services rated 800 amperes or less. No more than two sets of service entrance conductors, with their end terminations grouped at one location shall be connected to a service drop.

At single-phase installations where the anticipated demand as determined by the Company does not exceed 72 kVA, a self-contained meter shall be used; see Section 7. Where the anticipated single-phase demand exceeds 72 kVA, a current transformer installation shall be provided by the Company as indicated in Section 7. Where the anticipated demand exceeds 100 kVA, three-phase service is required.

Figure 4.2.1-1 Typical Overhead Service Installation under 600V

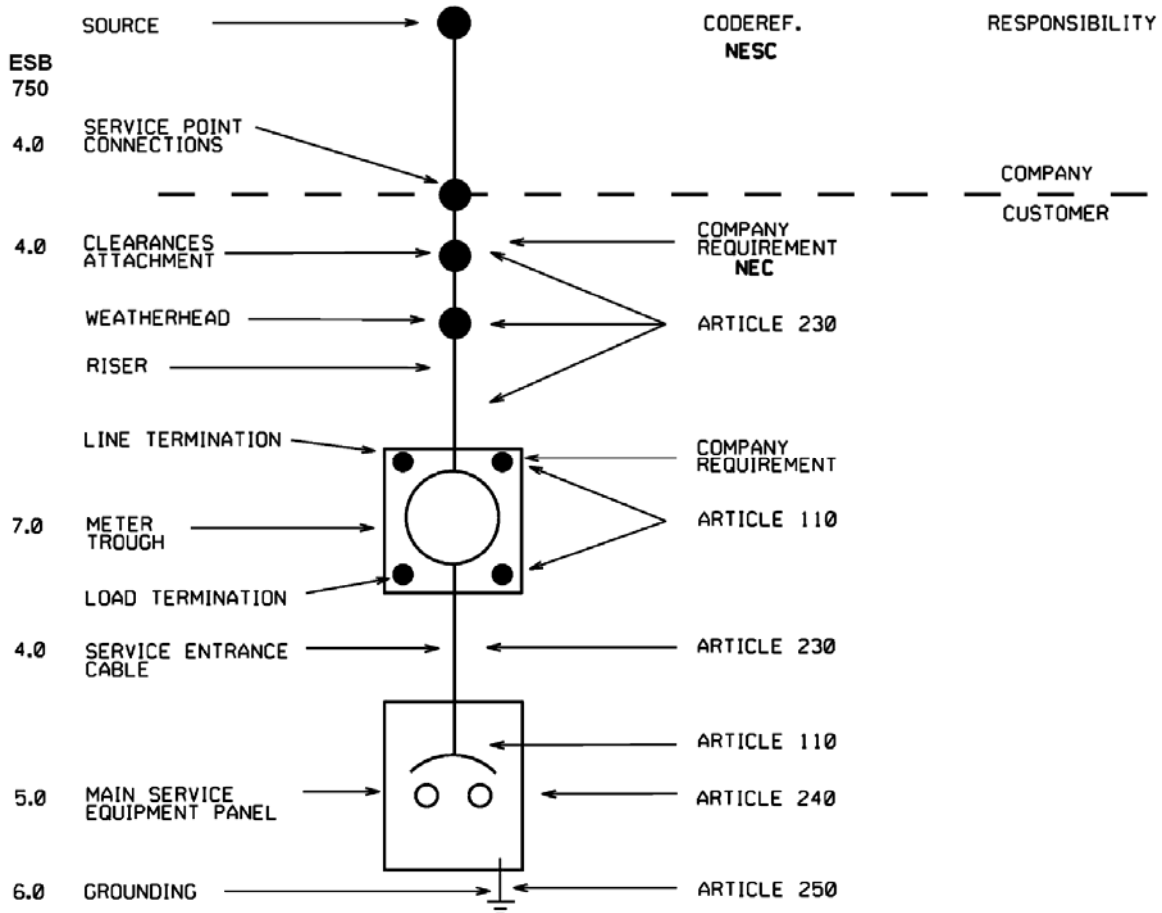

4.2.2 Service Attachment, Location

The Customer shall furnish, own, and install a 600 volt insulated service bracket assembly to which the Company’s service drop will be attached; see Appendix 1. This assembly shall be properly affixed to a structural member of the supporting building, service pole, or riser mast, and capable of withstanding the tension shown in Table 4.2.4.3-1 for the size of the service being installed. Attachments to chimneys are not permitted. The service bracket shall be positioned below the service entrance conductor weatherhead as shown in Figure 4.2.2-1.

Figure 4.2.2-1 Typical Residential Overhead Service under 300 volts and 400 amperes

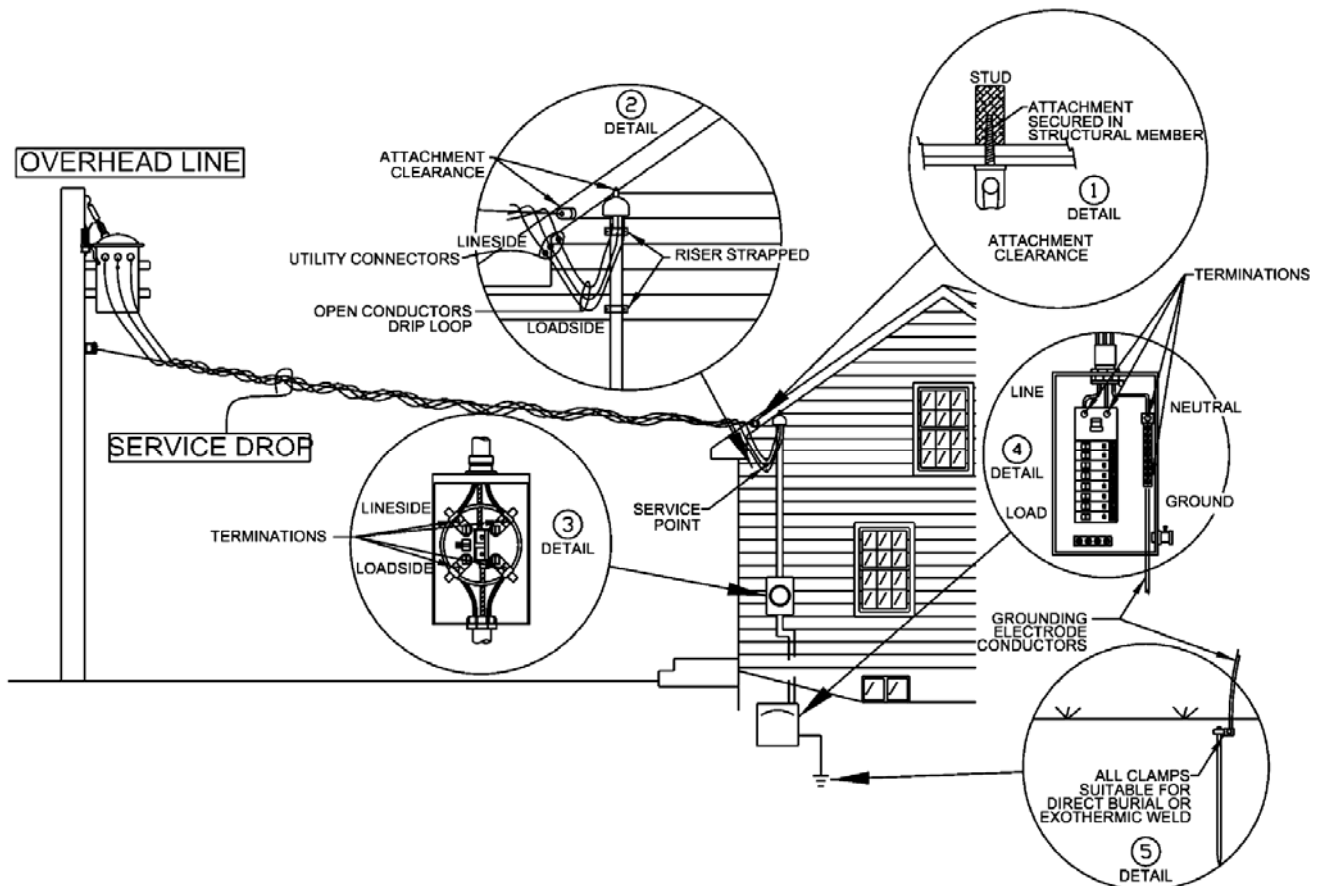

Notes to Figure 4.2.2-1:

- 1. Point of Attachment –** Installed by customer or customer’s electrician at proper clearance. See Sections 4.2.4.1 and 4.2.4.2 and NEC Sections 230.24 and 230.26 and APPENDIX 1.
- 2. Drip Loop –**
 - A.** To prevent the entrance of moisture drip loops shall be formed on individual conductors. See Section 4 and NEC 230.54.
 - B.** Open conductors’ clearances from openings – See Section 4.2.4.1 and NEC 230.9.
- 3. Meter Socket Trough –**
 - A.** Location, Mounting, and Work Space - See Section 7 and NEC 110.26.
 - B.** Independent Test Laboratory Certification – See Section 7.2 and NEC 110.3.
 - C.** Service conductors connected in terminals – See Sections 7.2 and 7.3 and NEC Sections 110.14 and 312.5.
- 4. Service Equipment (Main Disconnecting Means and Overcurrent Protection) –**
 - A.** Main means to disconnect and protect from overcurrent all premises wiring conductors. See Section 5 and NEC Sections 230.70, 230.71, 230.72, 230.90, and 230.91.

January 2019

- B. Service conductors shall be connected to the service disconnecting means. See Sections 4 and 5 and NEC 230.81.
- 5. **Grounding and Bonding** – The service equipment shall be grounded. See Sections 5 and 6 and NEC Sections 250.4 and 250.24.
- 6. **Electrical Inspection by the AHJ** – Final inspection through inspector field verification and approval. See Section 1.9 and NEC Sections 90.4, 90.7, 110.2, and 110.3.
 - A. Inspection approval sticker on right side of meter socket trough. See Section 1.9 and NEC 110.2.
 - B. For third party inspection agencies, see utility agreement for electrical inspection agencies and NFPA Electrical Inspection Manual. For other references see NFPA standards 73, 70B, and 70E.

4.2.3 Customer-owned Service Pole (When approved by the “Company”)

On farms, or other locations, where several buildings or structures are under one ownership; and, where a single electric service point and billing meter are feasible (service rating, 800 ampere, maximum), a Customer furnished, installed, owned and maintained service pole, complete with billing meter and service equipment, may be permitted. A service pole shall be installed according to the requirements noted in the Figure 4.1.10-1. All materials and methods used shall not be less than those specified in the applicable figures. For a service drop greater than 30 feet (9.0 m), guying of the pole is required. The Company shall be consulted in each case to determine installation requirements.

4.2.4 Overhead Service Line Clearances

Liberty Utilities’ overhead service line conductors must comply with the clearance requirements of the National Electrical Safety Code and Liberty Utilities’ Overhead Construction Standards. The Customer’s service bracket, located near the point of attachment, must be installed in such a location to allow for minimum clearance of overhead service line conductors to be met. Placement of swimming pools under existing overhead service line conductors is prohibited. Should a new service require placement over an existing swimming pool, the Company must be consulted to insure that minimum clearance requirements can be met. In all cases, the Company shall determine the location of the point of attachment.

4.2.4.1 General Overhead Service Line Clearances

The following general clearances are in effect for Liberty Utilities’ overhead service line conductors:

Clearance Requirement	Effectively Grounded Neutral, Grounded Guys and Ungrounded Guys Exposed to 0 to 300V		0 to 750V Multiplex Supply Cables	
	(ft.)	(m)	(ft.)	(m)
Vertical clearance above roads, streets, alleys, parking lots, driveways and other areas subject to truck traffic.	17.0	5.2	17.5	5.4
Spaces and ways subject to pedestrians or restricted traffic only.	12.0	3.4	13.5	4.2
Vertical or diagonal clearances over or under roofs or projections not readily accessible to pedestrians.	4.5	1.4	5.0	1.6
Vertical or diagonal clearances over or under balconies or roofs readily accessible to pedestrians.	12.0	3.7	12.5	3.9
Maximum vertical height above ground to service drop drip loop from finished grade.	25.0	7.7	25.0	7.7
Any direction from eaves trough or downspout.	0.5	0.2	0.5	0.2
Clearance in any direction to <u>unguarded</u> windows or doors.	4.5	1.4	5.0	1.6

January 2019

Clearance Requirement	Effectively Grounded Neutral, Grounded Guys and Ungrounded Guys Exposed to 0 to 300V		0 to 750V Multiplex Supply Cables	
	(ft.)	(m)	(ft.)	(m)
Vertical above window top and around <u>non-opening</u> windows (with no sag adders).	1.0	0.4	1.0	0.4

4.2.4.2 Clearances to Swimming Pools

Customers with noted clearance violations caused by the placement of an above ground or in-ground swimming pool will be responsible for the relocation of the swimming pool or the cost of relocation of overhead conductors to meet the Company's minimum clearance standards. Electric service will be discontinued if correction cannot be made within a reasonable time frame as determined by the Company, see Section 3.12.

Service lines within 25' (7.6 m) of the edge of the water surface of the swimming pool must meet the minimum requirements as described in the table below, otherwise, the standard clearance requirements above must be adhered to.

Clearance Requirement	Effectively Grounded Neutral, Grounded Guys and Ungrounded Guys Exposed to 0 to 300V		0 to 750V Multiplex Supply Cables	
	(ft.)	(m)	(ft.)	(m)
Clearance in any direction from the water level, edge of pool, base of diving platform, or anchored raft.	23.5	7.2	24.0	7.4
Clearance in any direction to the diving platform, tower, water slide or other fixed pool-related structures.	15.5	4.8	16.0	4.9

4.2.4.3 Service to Low Buildings

Where the Customer's building or structure is too low to serve as the attachment point for the service bracket, and clearances described by Section 4.2.4 cannot be met, the Company shall be consulted. When National Electrical Code and National Electrical Safety Code standards permit, the Customer can submit the matter to the Company which may approve the installation of the service bracket at an alternate point. As another alternative, the Customer may install a service "riser" to mount the service bracket at the required height. This service "riser" shall be galvanized rigid steel conduit or a galvanized structural steel member similar to the design shown in Figure 4.2.4.3-1. This service riser shall be capable of withstanding the service drop tensions in Table 4.2.4.3-1. The conduit for service riser masts shall be at least 2-1/2 inches (63). Where mast heights exceed the maximum heights allowed by Table 4.2.4.3-1, an anchor may be installed to resist the bending moment imposed by the wire as shown in the bottom of the table. Where clearance remains a problem, the Company recommends the Customer install an underground service lateral and service conductors as described in Section 4.5.

January 2019

Table 4.2.4.3-1 - Galvanized Riser Mast Bracing Requirements

Galvanized Steel Riser Mast								
Maximum Unbraced Height From Roof to Attachment Bracket								
See Details in Figure 4.2.4.3-1.	Service Rating							
	1 Phase 200A & Below		3 Phase 150A		1 or 3 Phase 400A		3 Phase 800A	
	lb.	kN	lb.	kN	lb.	kN	lb.	kN
Service Cable Tension →	650	2.9	680	3.0	1000	4.4	2000	8.9
Riser Material:	in.	cm	in.	cm	in.	cm	in.	cm
Angle Size								
3" (75 mm) x 3" (75 mm) x 1/4" (6 mm)	30	80	30	80	N/A	N/A	N/A	N/A
3" (75 mm) x 3" (75 mm) x 3/8" (10 mm)	42	110	42	110	24	60	2 @ 24 ea.	2 @ 60 ea.
3-1/2" (90 mm) x 3-1/2" (90 mm) x 3/8" (10 mm)	48	120	48	120	42	110	2 @ 42 ea.	2 @ 110 ea.
Channel Size								
6" (150 mm) x 2" (50 mm) - 8.2 lb (3.7 kg)	24	60	24	60	N/A	N/A	N/A	N/A
8" (200 mm) x 2-1/4" (57 mm) - 11.5 lb (5.2 kg)	42	110	36	90	24	60	2 @ 24 ea.	2 @ 60 ea.
9" (225 mm) x 2-1/2" (65 mm) - 13.4 lb (6.1 kg)	48	120	48	120	30	80	2 @ 30 ea.	2 @ 80 ea.
I-Beam Size (Detail B)								
4" (100 mm) x 2-5/8" (66 mm) - 7.7 lb (3.5 kg)	36	90	30	80	N/A	N/A	N/A	N/A
5" (125 mm) x 3" (75 mm) - 10.0 lb (4.5 kg)	48	120	48	120	36	90	2 @ 36 ea.	2 @ 90 ea.
6" (150 mm) x 3-3/8" (85 mm) - 12.5 lb (5.7 kg)	48	120	48	120	42	110	2 @ 42 ea.	2 @ 110 ea.
Nom. Diameter Steel Conduit (Detail A)								
2.5 inch (63)	36	90	30	80	24	60	2 @ 24 ea.	2 @ 60 ea.
3 inch (78)	48	120	48	120	36	90	2 @ 36 ea.	2 @ 90 ea.
3.5 inch (91)	48	120	48	120	48	120	2 @ 48 ea.	2 @ 120 ea.
4 inch (103)	48	120	48	120	48	120	2 @ 48 ea.	2 @ 120 ea.
Minimum Guy Wire Bracing	5/16" (8mm)		5/16" (8mm)		3/8" (10mm)		1/2" (13mm)	

Figure 4.2.4.3-1 Overhead Service Attachment and Riser Mast Requirements

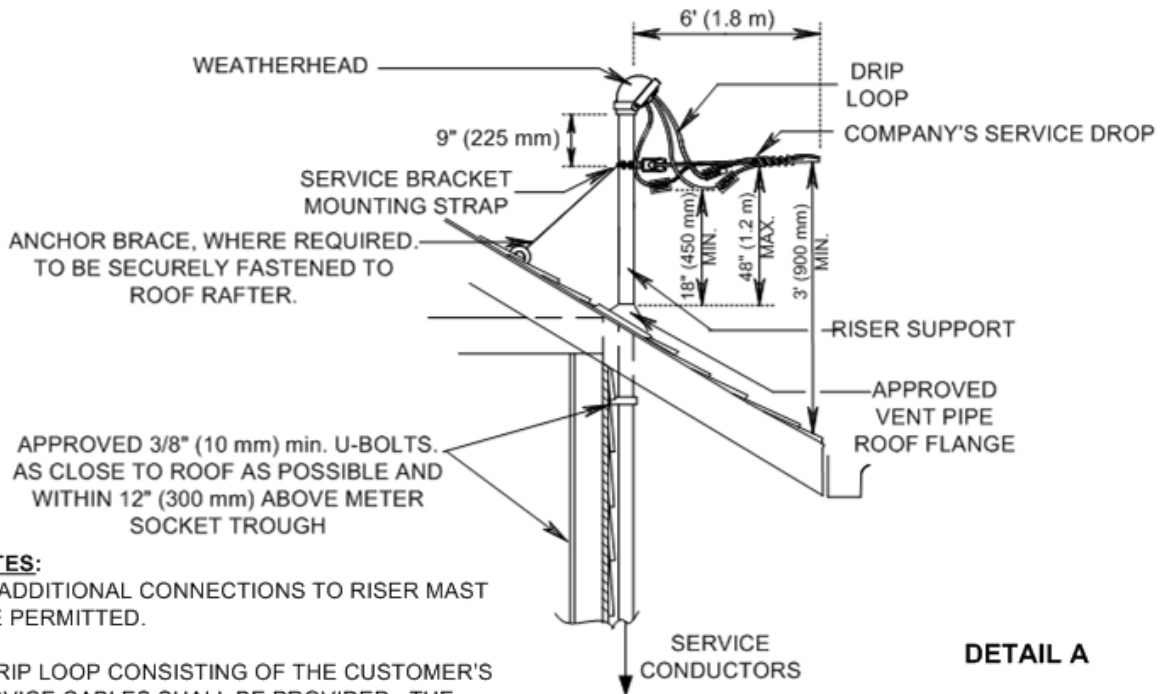

NOTES:

NO ADDITIONAL CONNECTIONS TO RISER MAST ARE PERMITTED.

A DRIP LOOP CONSISTING OF THE CUSTOMER'S SERVICE CABLES SHALL BE PROVIDED. THE LOOP SHALL MAINTAIN CLEARANCES SHOWN ABOVE THE ROOF AND SHALL BE INSTALLED WITHIN 6' (1.8 m) OF MAST.

UPON INITIAL INSTALLATION, LEAVE 24" (600 mm) OF SERVICE CONDUCTORS BEYOND ATTACHMENT BRACKET FOR SERVICE CONNECTION BY COMPANY.

SERVICES GREATER THAN 400A SHALL HAVE TWO MASTS WITH THEIR SERVICE CONDUCTORS PARALLELED AT ONE END.

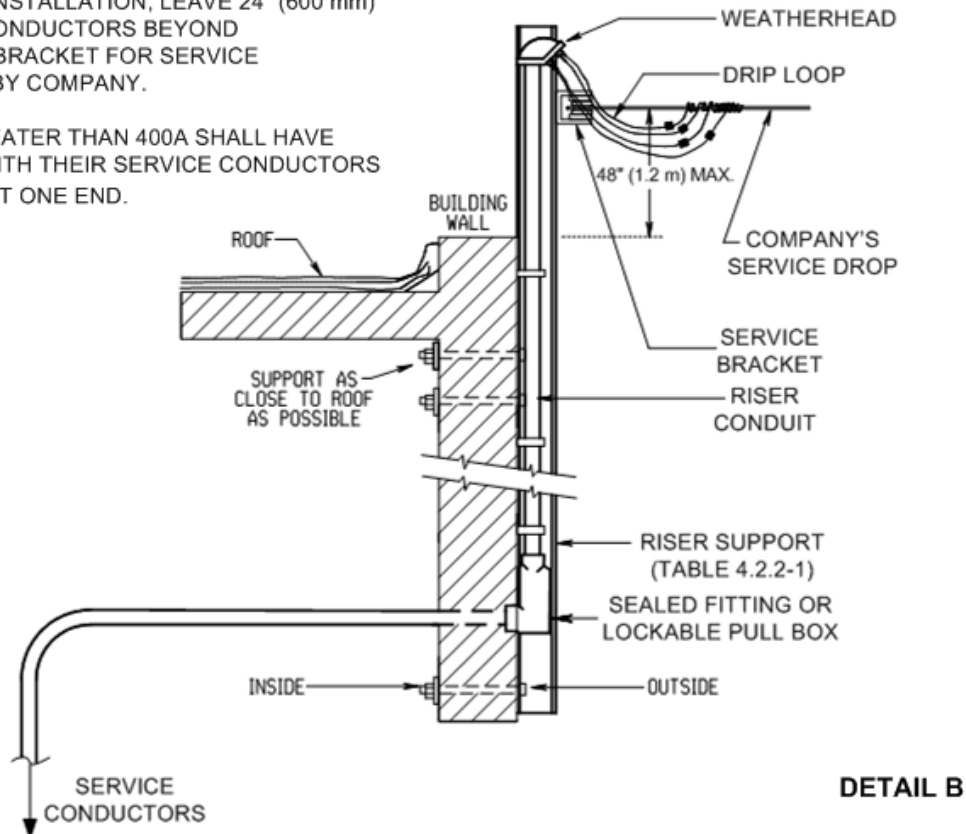

January 2019

4.2.5 Service Drop and Connection to Service Conductors

The Customer shall furnish, install, own and maintain all service entrance conductors and point of attachment. The Company shall make all connections, permanent or temporary, between the overhead service drop and these entrance conductors. The Company will not permit this connection to be made by others. (Exception: during emergency storm restoration the use of temporary connections may be allowed to be installed by electrician in communication with the AJH).

At least twenty-four inches (600 mm) of each service entrance conductor shall project beyond the weatherhead or termination of the service entrance cable for connection to the service drop conductors. Manufactured weatherheads shall be mounted vertically and filled with duct seal to inhibit water penetration.

The service entrance cable itself, or the conduit, or wireway containing the service entrance conductors, shall be exposed from the connection at the service drop conductors to the meter location, except where this service entrance directly passes through a roof or building wall. These openings shall be weatherproofed to prevent the entrance of water and protect the service conductors from physical damage up to the service equipment.

4.2.6 Customer's service meters are not allowed on Company owned poles

A customer's service meter (commercial and residential) is not to be installed on a Company JO or SO pole whether it is located on public or private property. An exception to this company rule would be for a Company Primary metering service and Communication Company power supply installations (See APPENDIX 3). Refer to Section 4.2.3 Customer-owned Service Pole and 4.1.12 Service to Manufactured and Mobile Homes, Mobile Home Parks, and Recreational Vehicle Parks.

4.3 OVERHEAD PRIMARY VOLTAGE SERVICE CONNECTION (2.4KV TO 15KV INCLUSIVE)

Primary service, by its nature, provides more opportunity for a given primary Customer to directly affect other electric system customers. Primary customers are responsible for obtaining and maintaining their own equipment.

The Company provides a number of services of this type. Normally, such services are three phase. Depending upon site location, actual service voltage, and use characteristics, certain load restrictions may apply. The Customer is urged to contact the Company prior to planning for an overhead primary voltage service.

The Company constructs, owns and maintains all overhead primary service lines in the voltage range from 2,400 volts and above. Where intermediate support is required, or an extension of the primary service lateral or line is necessary, the Customer may be required to contribute to the cost of that portion of the service lateral or service line, in accordance with the Company's filed tariffs.

When the service lateral terminates in a building or vault, the section between the last pole and the building or vault shall be cable.

January 2019

4.4 UNDERGROUND SECONDARY SERVICE VOLTAGE CONNECTION (UNDER 600V)

4.4.1 General

The Company will provide an underground secondary service connection by one of the following methods:

- Underground secondary service connection from the Company's overhead distribution supply line. All new **residential** services the Company will install, own, and maintain the underground secondary service conductors. Refer to **Appendix 4: ESB No. 759C Residential Underground Services**
For all commercial services (120/240V, 120/208V & 277/480V) the Customer shall install, own, operate, and maintain the underground service conductors (refer to Figure 4.4.4.2-1 Underground Secondary Service Riser Pole Detail).
- Underground secondary service connection from the Company's underground distribution supply line. New **residential** services the Company will install, own, and maintain the underground secondary service conductors. Refer to **Appendix 4: ESB No. 759C Residential Underground Services**
For **commercial** services the Customer shall install, own, operate, and maintain the underground service conductors

4.4.2 Facilities in Shared Trench

The Customer's underground electric service lateral may be installed in the same trench as facilities providing other utility services in accordance with the National Electrical Code and the National Electrical Safety Code. The Customer should contact the owners of these other utility facilities for their requirements on the use of shared trench. The Company shall be consulted for its requirements when its underground distribution line or service lateral cable is involved with trench shared with other underground facilities.

The use of a common trench for Customer owned underground facilities and Company distribution lines is not permitted; however, a perpendicular crossing may be allowed after approval by the Company.

4.4.3 Conduit System

The customer or its contractor is responsible for the trenching and conduit system installation. The Company or Authority Having Jurisdiction (AHJ) will inspect and approve the conduit system and trenching prior to backfill. Certain conduit construction techniques are essential to maintain the integrity of an electric service over its lifetime. For services less than 600 volts, Company conduit requirements are minimal, covering only situations where both the Company and the Customer have a mutual interest; however, the Customer's conduit installation shall meet the National Electrical Code. The Company requires that all conduits on the line side of the revenue metering be installed in a secure manner. No conduit body fittings (condulets) or unlocked access panels are permitted. For network services and services above 600 volts, where the Company furnishes, installs, and thereafter maintains the cable, there are more requirements as noted in this book.

Where conduit installations are made, it is especially important where future placement of conduit will be awkward, time consuming, and costly that a spare conduit be provided. Spare conduit is required for primary service laterals and all network services. Where the underground secondary voltage service cable terminates on the outside of a building in a meter socket or trough, the cable shall be protected by conduit. Where the underground secondary voltage service cable terminates in a building, the cable through the wall shall be protected by conduit.

For services supplied from radial underground systems, the Customer shall seal conduits where they enter the building to limit water ingress from either around or within the service conduits. For services supplied from the secondary network, the Customer shall install a fire-stop conduit seal to limit ingress of water, smoke, fire, and hazardous gases from either around or within the service conduits. The Customer is responsible for meeting the NEC and any other code requirements as necessary for sealing of underground conduits.

4.4.4 Underground Secondary Service Connection from the Company's Overhead Distribution Supply Line

4.4.4.1 Residential Underground Secondary Service Conductors (New installs as of 01/01/2019)

Where the Company elects to provide service from its overhead distribution supply line, the **Company shall own, operate, and maintain the underground service conductors from the service point at the Company's supply line to the service equipment.** Refer to **Appendix 4: ESB No. 759C Residential Underground Services.**

4.4.4.2 Commercial Underground Secondary Service Conductors

Where the Company elects to provide service from its overhead distribution supply line, the **Customer shall own, operate, and maintain the underground service conductors from the service point at the Company's supply line to the service equipment.** The Customer's underground service conductors installed in the public way shall be as permitted by the Customer according to the Company's applicable tariff. The Customer shall also be responsible for the conduit, fasteners and trenching required to attach to the Company's distribution pole. The conduit for underground service risers shall have an inside diameter of at least 2 inches (50 mm) see Figure 4.4.4.2-1.

Where the Company's pole is not located on the same side of the road as the proposed underground service, the Customer shall contact the Company to discuss the necessary arrangements. In some instances and in some roadway jurisdictions, the Customer may be allowed to install their own conduit and underground service cable across the road. Otherwise, the Company may be required to install an additional distribution pole on private property; the Company will designate the location, to provide this type of service. In these instances, as is the case with all customer riser pole installations, the Company requires an inspection of the installation, including the riser pole location, fastening and grounding only after the Company has set the required pole and all work in association with the electric service has been completed. Note, depending on the roadway jurisdiction and if service is in the public way, a petition to the roadway jurisdiction may be required, which will be obtained by the customer.

4.4.4.3 Company Riser Pole Attachments

The Company will permit the use of PVC Schedule 80 conduit on secondary voltage service riser poles. The conduit shall be placed flush to pole designated by Company, in a location on the pole away from traffic. **Primary voltage services must be installed within galvanized rigid steel conduit.** See Figure 4.5.4.2-1 as follows for requirements. Whether the riser is to be located in the street or on private property, the Customer shall furnish underground service conductors of sufficient length to reach the Company's secondary conductors on the pole or the transformer secondary terminals. **The maximum number of service conductors is two (2) per phase and is limited to maximum size of 500 kcmil.** No more than four (4) shall be installed on a riser pole, occupying no more than one-half (1/2) the circumference of the pole. The Company will furnish and install (U-Duct) that portion of the riser above the 10-foot conduit supplied by the Customer. If the Company is required to change the location of the pole on which an underground service terminates, the necessary changes to the underground service shall be at the Customer's expense.

January 2019

Figure 4.4.4.2-1 Commercial Underground Secondary Service Riser Pole Detail

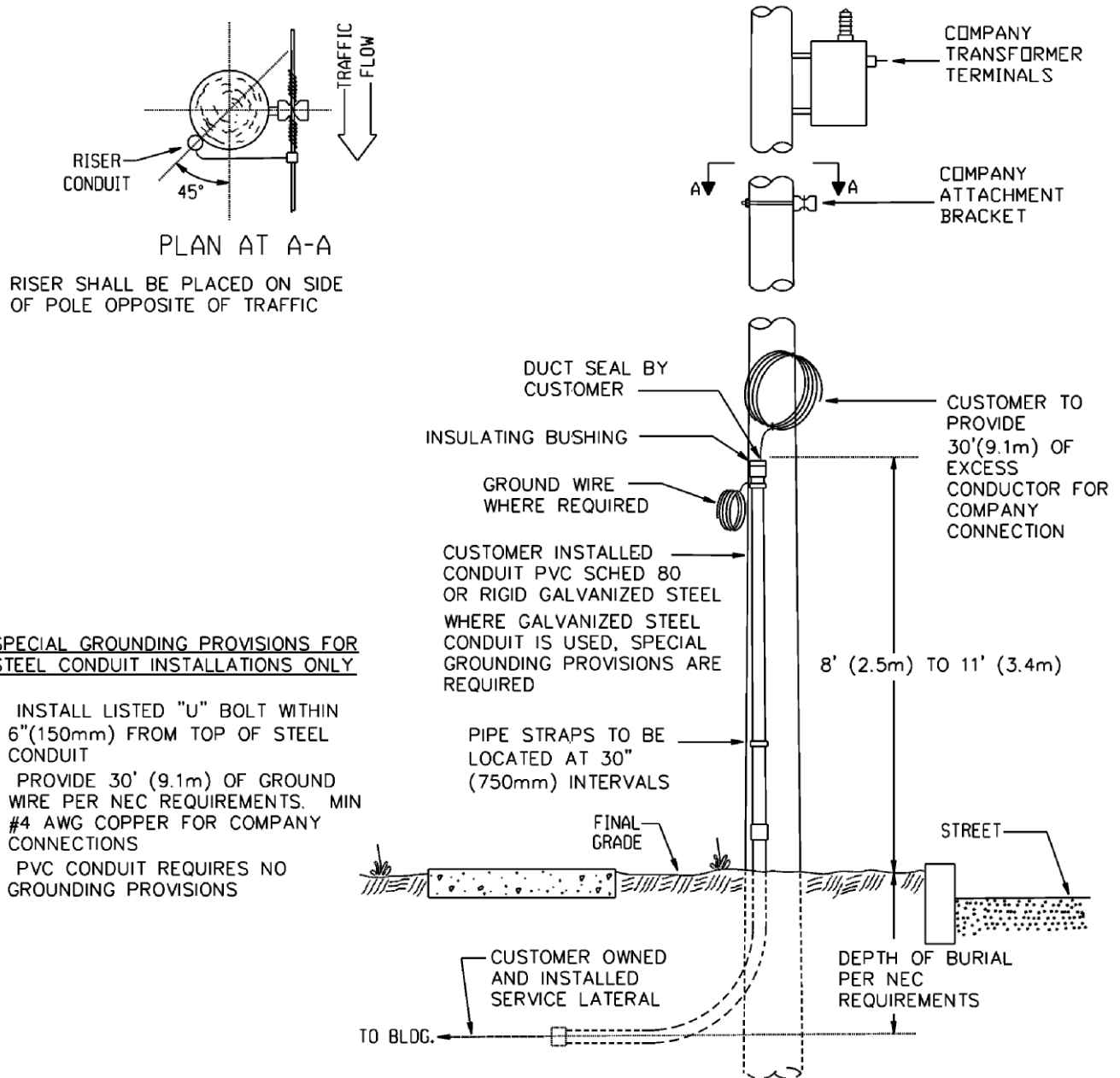

SPECIAL GROUNDING PROVISIONS FOR STEEL CONDUIT INSTALLATIONS ONLY

- * INSTALL LISTED "U" BOLT WITHIN 6" (150mm) FROM TOP OF STEEL CONDUIT
- * PROVIDE 30' (9.1m) OF GROUND WIRE PER NEC REQUIREMENTS. MIN #4 AWG COPPER FOR COMPANY CONNECTIONS
- * PVC CONDUIT REQUIRES NO GROUNDING PROVISIONS

4.4.5 Underground Secondary Service Connection from the Company's Underground Supply Lines (New installs as of 01/01/2019)

4.4.5.1 General

Refer to **Appendix 4: ESB No. 759C Residential Underground Services.**

Services of this type are normally found in underground residential developments (URD). **The Company shall own, operate, and maintain the underground service conductors from the service point at the Company's supply line to the service equipment.** Before proceeding with the work, the Customer (or Customer's Electrician) shall consult the Company as to the location of the service conduit and to identify the Company's service point. The service point location in an URD would be designated by the Company and would be a Company handhole or transformer padmount located at the property line. Refer to Figure 4.4.5-1 on the following pages for detail instructions.

Figure 4.4.5-1 Underground Residential Distribution (URD)

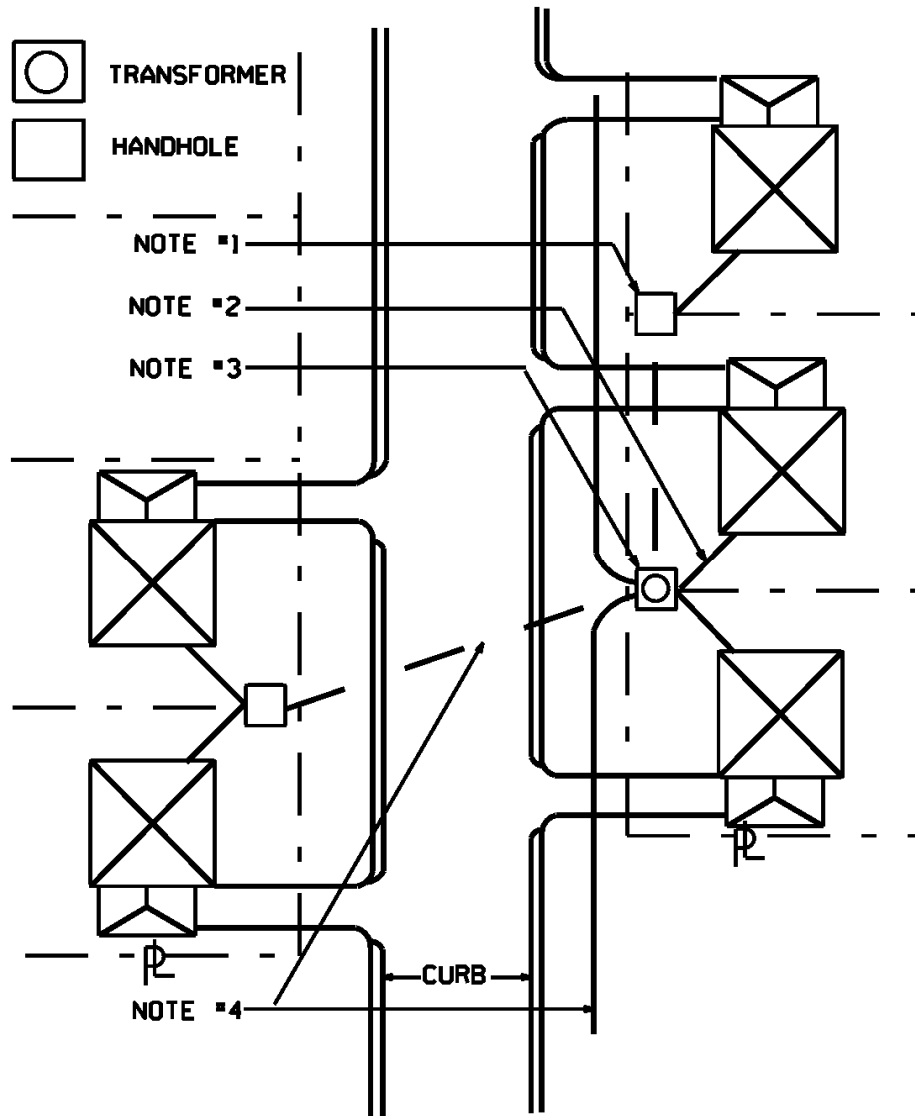

Refer to Liberty Utilities Supplemental Company Specification ESB No. 759A Underground Residential Distribution (URD) Guidelines for URD requirements for installation.

In URDs, the developer is responsible for the installation of a 3 inch PVC stub from handhole or transformer foundation pad for each future underground service served from the approved lot subdivision being served by the URD system.

For a residential underground single phase 120/240 volt service greater than 400A through 800A contact a Liberty Utilities electric service representative. These services, even on a small scale, present many unique challenges for the Company. Refer to Section 7.4 Transformer-Rated Metering 600 Volts and Less.

January 2019

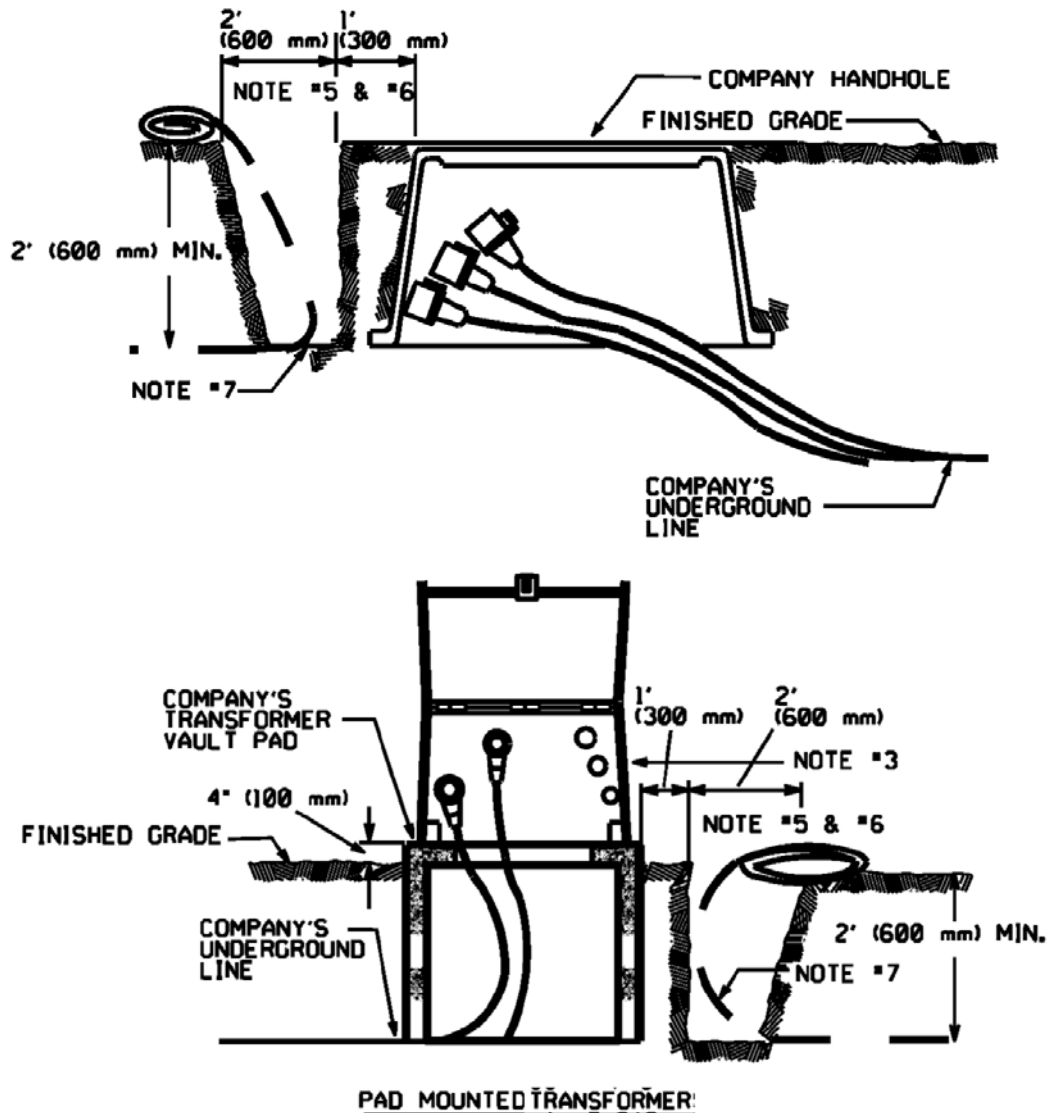

Notes to Figure 4.4.5-1:

- NOTE #1 Handhole by Company.
- NOTE #2 Underground service conductors.
- NOTE #3 Single phase transformer by Company.
- NOTE #4 Company's underground line.
- NOTE #5 200 A service -- not more than one set of service conductors – maximum size 4/0 AWG.
- NOTE #6 400 A service -- not more than one sets of service conductors, maximum size 350 kcmil.
- NOTE #7 Customer to seal cable ends to prevent entrance of moisture during installation.

- NOTE #8 Customer to trench and install conduit system to handhole or transformer pad foundation. If no conduit stub exists contact Company for access to company owned equipment. Conduit system shall be inspected and approved by AHJ or company.
- NOTE #9 The Company is committed to the pursuit of safety excellence through compliance with all OSHA, State, and Regulatory requirements. The Company advises the Customer or their Contractor to comply with the same requirements for safe trenching.

Figure 4.4.5-2 Underground Secondary Service Residential Meter Connection – Conduit

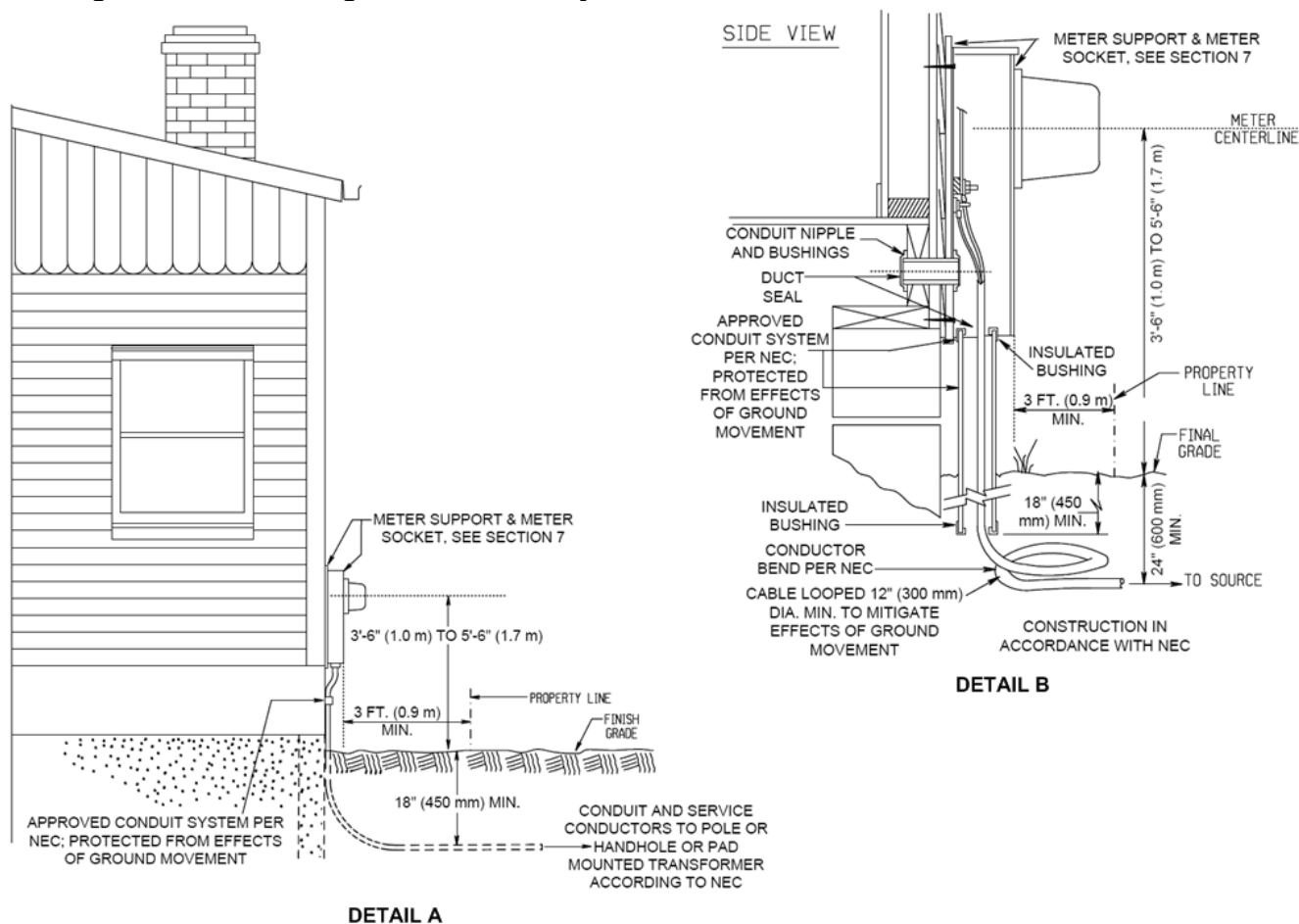

4.4.6 Underground Secondary Service Connection

4.4.6.1 From a Company-owned Primary Underground Service Lateral

Depending on the nature of service and/or the distance to the nearest Company supply point, the Customer may require a primary radial service lateral for a single phase Company-owned transformer, on private property. The Customer is responsible for the trenching and installation of conduit system from the primary supply point to the Company owned transformer to Company’s designed layout and specifications. The Company will install, own, and maintain the primary cable. Contact Liberty Utilities’ Electric Service Representative for more detail information and applicable Company Policy.

4.4.6.2 Service to Multiple Occupancy Buildings

These services, even on a small scale, present many unique challenges and often require extensive off-site and on-site electrical system work by the Company. **Liberty Utilities shall be contacted and consulted for Company requirements for multiple occupancy and high-rise buildings.** The initial goal for services of this type is the submittal of an approved plot plan complete with electrical facilities shown. This consultation is to include but not limited to, the number of metering rooms, the location of the metering rooms(s) and accessibility. Be sure to refer to the requirements in Sections 3.1, 3.4, and 4.1.1 in particular and Section 7.0 **METERING**. The appropriate Company representative will outline the service connection requirements necessary to provide electric service to the building and its tenants.

In General, group metering and/or metering rooms should be in one location and on ground floor and must be readily accessible to the Company personnel at all times.

All Meter Locations Must Be Pre-Approved By The Company.

January 2019

Unless otherwise exempt by the Company's tariff, the Company will provide underground distribution to a residential multiple occupancy building and the Customer will provide the necessary facilities for the padmounted transformer installation and conduit system installation. Primary underground lines installed to serve these buildings are considered underground residential or commercial distribution extensions.

For services above 600 volts consult the Company.

Where there is an inquiry for supplying service to individual tenants within a building, the Customer shall install and maintain feeders from a Company designated service entrance location to connect each such tenant. The Customer shall provide transformation required for other utilization voltages within the building on the load side of the meter.

4.5 UNDERGROUND PRIMARY VOLTAGE SERVICE CONNECTION (FROM 2.4KV TO 15KV INCLUSIVE)

Refer to the Company's Electric System Bulletin ESB No. 759B Section 7.0 Responsibility and Ownership and contact Liberty Utilities' Electric Service Representative at least 6 months prior to your service requirement date, so that all details concerning the design and installation of an Underground Primary Radial Service located on private property can be initiated. The division of ownership and responsibility shall be as specified by the State of New Hampshire PUC Tariff for Retail Delivery Service. For Liberty Utilities NH the customer will provide, install, own, and maintain the conduit system and transformer pad, reinforcement and grounding (per Company specifications and Designed Layout). The Company will designate the riser pole or switchgear and padmount transformer location, and provide, install, own and maintain the primary cable and Padmounted Transformer, Current and Potential Transformers and Metering.

Also, see Section 7 for metering requirements.

5.0 SERVICE EQUIPMENT

5.1 GENERAL

Most of the Company's requirements in this section account for specific Company operating practices or concerns. Company imposed requirements address in particular: network services, where high fault values are available; theft of service precautions; and certain required service configurations to permit the Company to operate its supply system in a safe and reliable manner for all customers.

5.1.1 Service Equipment Required

Service Equipment shall be furnished, installed owned and maintained by the Customer as part of the permanent wiring of each service entrance for any Company-provided service.

All service equipment shall meet the requirements of the National Electrical Code and all local authorities having jurisdiction. Service equipment rated above 400 amperes shall also meet the requirements of the American National Standards Institute and National Electrical Manufacturers Association (NEMA) as well as the additional requirements as outlined in this section. All service equipment housed in a compartment shall be adequately ventilated to limit the temperature rise in accordance with the latest NEMA Standards.

As stated in the National Electrical Code (NEC), Customer service equipment shall be located at the nearest point of entrance of the service conductors and ample workspace shall be provided. On group installations, all service equipment shall be permanently marked by the Customer to clearly identify the space, office, store, apartment, etc. to which it is connected.

5.1.2 Service Equipment Minimum Continuous Current Rating

For single residential and small commercial applications, service equipment shall have a minimum rating of 100 amperes. Consult the Company for acceptable minimum service equipment ratings for other uses.

5.1.3 Service Equipment Minimum Short Circuit Withstand Capability

Service equipment shall be suitable for the short circuit current available at its supply terminals. For residential single phase services supplied from the Company's radial supply system, the minimum short circuit withstand current shall be no less than 10,000 amperes RMS symmetrical. For services supplied directly from a transformer, see Section 9.3 for available fault current. For network services, see Section 5.3.

5.1.4 Routing of Metered and Unmetered Conductors

See Section 4.1.7. Portions of the service equipment shall have provisions for security locking by the Company from the supply point to the metering location where they contain unmetered conductors.

5.1.5 Taps Ahead of Main Service Equipment

Any tap made ahead of the main service equipment for emergency systems, control power for circuit breaker, etc. shall be provided with disconnecting means and overcurrent protection adequate for the duty. Such connections shall be made only where specifically accepted by the Company and approved by the NEC.

5.1.6 When Service Equipment Ahead of Metering is Required

Refer to Section 7 for accepted metering configurations where a Customer shall install main service equipment ahead of metering in applications 600 volts and less. Consult the Company for metering and service equipment configurations in applications above 600 volts.

January 2019

5.1.7 Service Equipment on Service Poles, Pedestals, or Posts

5.1.7.1 Service equipment must be installed by the Customer on all service poles, pedestals, or posts:

- where the service pole, pedestal, or post is greater than 10 feet (3.0 m) from a single building or structure; see the NEC for disconnect requirements in the building;
- where more than one building or structure is supplied by a service pole that is served overhead by the Company; and
- for mobile home(s).

Note: Conduit is required for all service entrance conductors installed underground between the meter and service equipment.

5.1.7.2 **Meter** pedestals are free-standing units intended to be mounted outdoors on a concrete pad in conjunction with underground wiring. If a free-standing meter pedestal is used, it shall extend a minimum below the finished grade or ground line with stabilizing means extending below the frost line to ensure that the meter mounting stays in a plumb position. See Section 7 for further details. Meter pedestals for self-contained metering must be listed devices and shall also incorporate circuit breakers, but these are not intended to replace the service disconnecting means required at the building.

5.1.8 Grouped Metered Services to Separate Buildings on One Premise

Where the Company and local AHJ approve more than one metered service to separate buildings on a Customer's premise, all metering shall be grouped at a specific location(s) approved by the Company. These metered services shall have associated service equipment on the load side of the meter at the grouped meter location. All meters and service equipment must be properly identified.

5.1.9 Service Equipment Arrangement

The Service Equipment may consist of multiple circuit breakers or fused switches with fuses, provided:

- the number of breakers or fused switches does not exceed six;
- breakers and fused switches must be in a common enclosure, or in a group of separate enclosures grouped in one location.

Exceptions:

- Service to a building in a network area having main switch capacity up to and including 4,000 amperes requires a single main disconnecting device.
- Service to a building in a network area having main switch capacity greater than 4,000 amperes, may generally have a maximum of three main disconnecting devices, with no device smaller than 2,000 amperes.
- Service less than 600 volts from an underground distribution line (excluding URD and UCD) requires a single main disconnecting device.
- Standby generation with a transfer switch need not be grouped; however, identification is required in accordance with the National Electrical Code.
- A Customer-designated emergency system that requires separate service equipment for a Customer supplied by the Company's radial system. This service equipment shall be located within 100 circuit feet (30 circuit meters) from a padlockable load break disconnect switch installed in the service entrance cable at the building's grouped main service equipment location.

Any service equipment located on the line side of meters (cold sequence) shall be an enclosed type, with facilities for sealing by the Company. Fuse replacement or breaker reset must be possible without disturbing the enclosure seal.

Where multiple service equipment is provided for either commercial or dwelling occupancy, each disconnecting means shall be marked in a conspicuous, legible, and permanent manner to indicate which portion of the installation it controls.

January 2019

5.1.10 Service Equipment Minimum Attributes

Service equipment 600 volts and less shall meet the following minimum requirements:

5.1.10.1 Interrupting Rating

See Section 5.1.3 and the National Electrical Code to select proper service equipment to withstand the maximum available fault current from the Company's supply and utilization equipment contribution.

Overcurrent protection shall provide fault interrupting capability, at service voltage, not less than the value specified by the Company (see Section 9).

The disconnecting means shall be capable of opening load current.

5.1.10.2 Inductive Heating

Current carrying parts shall be sufficiently spaced from enclosure metals to preclude inductive heating. Enclosures of nonferrous metals may be used, if desired.

5.1.10.3 Metering Transformer Space

Where used, provide required space and accessible mounting facilities for the Company's metering transformers based on full rating of the service equipment.

5.1.10.4 Bonding

All non-current carrying metal parts, mounting brackets, frameworks, enclosures, etc. shall be bonded to an equipment ground.

5.1.10.5 Spare Fuses

Where a switch and fuse combination is used, the Customer shall be responsible for maintaining a readily accessible stock of spare fuses.

5.1.10.6 Circuit Breaker

If an air circuit breaker is used, it shall meet the following requirements in addition to those in 5.1.10.1 and 5.1.10.4 above:

5.1.10.6.1 No Undervoltage Tripping

No undervoltage tripping devices except by Company's permission.

5.1.10.6.2 Control Circuit Protection

A control circuit used only for closing the circuit breaker may be connected on its line side provided the tap is protected by high interrupting capacity fuses of a type acceptable to the Company.

5.1.11 Instrumentation and Control Wiring

All instrumentation and control wiring shall utilize stranded conductors rated for the use intended, refer to IEEE Std. 525 for a design and installation guide of cable systems.

5.2 RESIDENTIAL

It is recommended that service equipment for a residence include the necessary feeder and branch circuit protective devices in accordance with the National Electrical Code.

5.3 NETWORK SERVICE**5.3.1 General**

Network Service is not available from the EPS in Liberty Utilities' service territory. Contact Company's Customer Care Group for new commercial service installations or upgrades in underground supplied systems.

5.4 RADIAL SERVICES

Service Equipment specifications and arrangements shall be discussed with the Company for approval prior to the purchase of equipment or proceeding with the installation.

The Company will inform the Customer concerning the magnitude of the current that the service equipment may be called upon to interrupt.

5.4.1 More than Six Service Disconnects

A single main service equipment shall be installed where there are more than six disconnects and overcurrent means at one location.

Where line-side connected, self-contained grouped meter sockets are installed, additional service equipment on the line side of meters is required if the number of line-connected meters exceeds six.

5.4.2 Radial Service, 300 amperes Continuous or Less Served at Less Than 600 volts

Note: Excluding URD areas, service equipment rated 300 amperes continuous or less served from radial underground lines shall conform to requirements of service equipment for network service. (See Sections 5.3.3 to 5.3.6)

Where the Service Equipment is rated 300 amperes continuous or less, and the secondary service voltage is as indicated, the Customer shall terminate its service entrance conductors at a location designated by the Company in the following manner: (See figures in Section 7.)

- in a self-contained meter socket for all 240 volt single phase and below including 208/120 volt three phase services.
- in service equipment on the line side of a self-contained meter socket for all 480 volt class services.

5.4.3 Radial Service, Above 300 amperes Continuous Served at Less Than 600 volts

Note: Service equipment rated above 300 amperes continuous, served from radial underground lines shall conform to requirements of service equipment for network service. (See Sections 5.3.3 to 5.3.6.) An overcurrent device on each pole of an air circuit breaker, if used, shall provide time delay overload protection and instantaneous tripping for currents of fault magnitude.

For service equipment less than 600 volts rated above 300 amperes continuous, it is important that the Company be consulted at an early stage concerning the design and coordination of the service lateral connections with the service equipment. The Customer shall submit detailed plans and specifications to the Company for approval before the purchase of the service equipment.

5.5 INDIVIDUAL MULTIPLE OCCUPANCY BUILDING SERVICE

In multi-occupancy buildings several stories high, the installation of unmetered risers in conduit to a single approved, accessible meter center located on various floors shall conform to the following criteria and be reviewed by the Company for acceptance and Approval. (**Non-Standard Installation**)

- Disconnecting and protective equipment shall be provided at the service entrance point for each floor level(s).
- Disconnects at the service point shall indicate the floor level(s) served.
- Where a single riser is being provided for several floor levels, disconnecting and protective equipment shall be provided at each grouped meter location. The purpose of this requirement is to allow isolation of equipment on a specific floor without affecting the service to other floors.
- Any disconnect, pull box or any access to unmetered conductors shall have provisions for sealing by the Company.

All Meter Locations Must Be Pre-Approved By The Company.

January 2019

5.6 RADIAL LOADS SERVED ABOVE 600 VOLTS

The Customer shall consult the Company in every case where the service voltage may exceed 600 volts. The Company will designate the type of service based on the location, size and nature of the proposed load and its relation to the Company's facilities. See Company's Electric System Bulletin Nos. 759A, 759B, or 756 for further details.

The location of the service equipment and the general electrical arrangement will be agreed upon after mutual consideration of all factors by the Customer and the Company. Based on the electrical arrangement selected, the Company will advise the Customer concerning its requirements for basic insulation level, protective equipment and metering facilities and will supply such additional information as short circuit data, relay recommendations, etc., so the Customer can complete the design of its installation. The Customer shall submit detailed plans for inspection and approval by the Company prior to the purchase of equipment or proceeding with the installation in accordance with the applicable supplement to these specifications noted above.

6.0 GROUNDING

6.1 GENERAL

This section applies to services 600 volts and below. Refer to the applicable supplements to these specifications and consult the Company for grounding applications above 600 volts.

6.2 EQUIPMENT TO BE GROUNDED

The Customer shall provide an effective ground and shall connect it to the service equipment and the following equipment in accordance with the National Electrical Code (NEC):

- The grounding stud of a self-contained meter socket trough for existing meter pole services without service equipment.
- The grounding stud of a transformer rated meter socket trough from the Customer's service ground or for pad mounted transformers, the transformer ground grid.
- The grounding stud and neutral bus of the service equipment.
- All metal service enclosures and conduits.
- The frames and secondary neutral of all instrument transformers.
- The rigid metal conduit riser on the Company's pole at a point ten (10) feet above ground.
- CSST gas piping systems shall be bonded to the electrical service grounding electrode system at the point where the gas service enters the building in accordance with NFPA 54. The bonding jumper shall not be smaller than 6 AWG copper wire or equivalent.

6.3 GROUNDING METHODS

6.3.1 All grounding shall be done in accordance with the NEC as a minimum or any other applicable code enforced by the inspection authority having jurisdiction. The Company is not responsible for problems or damage to customer equipment due to a less-than-optimum grounding electrode system. The Company shall not be liable for damage to the property of the Customer resulting from unbalanced voltage conditions due to the opening of a neutral service conductor.

6.3.2 In the absence of a suitable water piping system, the Customer's grounding system shall consist of electrodes as permitted by the NEC.

6.3.3 Achieving a resistance to ground value that exceeds NEC requirements provides better protection from lightning transients and can help improve power quality. A single grounding electrode, which does not have a resistance to ground of 25 ohms or less, shall be augmented by additional electrode(s) in accordance with the NEC.

6.4 GROUNDING RESTRICTIONS

Exclusive of the above requirements:

- Gas service piping and gas meters shall not be used as a grounding electrode for the connection of a grounding electrode conductor.
- A grounding electrode conductor shall not be connected to the meter socket trough.
- The meter socket trough shall not be used to ground other equipment.
- Consult the Company on existing 3-phase delta services no longer standard where the service conductors shall be insulated from the service equipment according to the NEC and grounded only at the Company's supply transformer.

6.5 GROUND FAULT PROTECTION

The Customer shall install ground fault protection for its equipment in accordance with the NEC.

7.0 METERING

7.1 GENERAL

In most instances, the Company will furnish, install, own, maintain, and connect all meters required for billing purposes at the delivery voltage on the Customer's side of the service point in accordance with the Company's applicable tariff and applicable state laws and regulations. This includes meter instrument transformers and meter cable when required. **All Meter Locations Must Be Pre-Approved By The Company.** The Company's metering equipment shall not be used to operate any Customer devices except for metering pulse signals as permitted in Section 7.6. The Customer, regardless of equipment ownership, shall permit minor alterations by the Company for the metering purpose. Service meters are not allowed on Company owned poles, an exception would be a Primary metered service and Communication Company metered power supply installations (See APPENDIX 3).

7.1.1 Access

It is in the interest of both the Customer and the Company that a suitable and adequately protected meter location be provided to ensure accuracy and to facilitate installation, reading, and maintenance. All metering equipment must be readily accessible to the Company's personnel at all times. The Company will designate this location. The Company requires the Customer to install its service wiring so that the meter is accessible to Company employees from the outside of the Customer's building in accordance with the Company's applicable tariff. Meter installations for services 600 volts and less up to and including 320 continuous amperes, normally will be located outdoors.

Meters shall not be installed in, or allowed to remain in areas that later become, stairways, fire escapes, coal bins, fruit cellars, bathrooms, toilets, bedrooms, attics, store windows, transformer vaults, behind shelves, near moving machinery or similar inconvenient or dangerous locations.

7.1.3 Working Clearances

7.1.3.1 Indoor Installations

In those cases where transformer rated meters or grouped meters are installed indoors, they shall be located as close as practicable to the point where the service enters the building and adjacent to the service equipment.

For multiple metering centers, the mounting height to the center of the meters shall be 6 feet (1.8 m) maximum and 2 feet (600 mm) minimum above floor indoors.

A clear working space of at least four feet (1.2 m) shall be provided and maintained in front of all meter socket covers with a minimum headroom of 6-1/2 feet (2.0 m). And should be located 3'-0" minimum from a sidewall or structure.

7.1.3.2 Outdoor Installations

The mounting height of individual or ganged meter troughs shall be mounted with the center of the meter 3-1/2 to 5-1/2 feet (1.0 to 1.7 m) above final grade. For multiple metering centers, the mounting height of the center of the meters shall be 6 feet (1.8 m) maximum and 2-1/2 feet (750 mm) minimum above final grade outdoors. And should be located 3'-0" minimum from a sidewall or structure.

For Traffic Signal services where the Company's service drop is attached to the Customer's traffic pole structure in the public way, the bottoms of the traffic control box, the meter socket trough, and any wire drip loops must be more than 8 feet (2.5 m) above grade. Or, the tops of the traffic control box and the meter socket trough must be below 6 feet (1.8 m) and there must be 8 feet (2.5 m) clear space without handholds or footholds starting at no higher than 6 feet (1.8 m) above grade. The meter socket trough shall be mounted in a location away from traffic for reasonable protection from damage and preventing climbing into energized overhead conductors.

January 2019

7.1.4 Physical Protection

Electric Meters shall be located away, or fully protected in a manner acceptable to the Company, from opening doors, commercial driveways, areas used for the piling of snow and where, in the Company's determination, the meter or service entrance is subject to damage through vibration or any other physical means. Examples of suitable protection methods include bollards, fender posts, guardrails, etc.

Where the meter is located in residential driveways or walkway areas, it shall be mounted to have reasonable protection from damage.

On a customer owned service pole, post, or pedestal, the meter shall be mounted to have reasonable protection from damage. Metering facilities for customers shall not be installed on a Company pole.

Where the Company provides the gas service, no electrical equipment or electric meter(s) shall be located directly over or under any gas meter or regulator vent. Eighteen inches (450 mm) of horizontal clearance shall be maintained between any electric meter socket and a gas regulator vent. Consult the Company prior to the installation of either service to avoid conflicts of meter location or where the gas service is supplied by others, consult that company.

7.1.5 Violations

Any Customer or Contractor wiring to a meter or service location that is not approved by the Company is done at its own risk. Corrections of such violations shall be at the Customer's or Contractor's expense.

7.1.6 Unmetered Wiring

The Company will seal all meters and meter facilities on the Customer's premises. All cabinets, equipment enclosures and conduit fittings containing unmetered wiring of any voltage shall be made secure before the service will be energized.

No conduit body fittings (condulets) or pull boxes in raceways containing unmetered service conductors are permitted. Where unavoidable in some special situations, pull boxes or wiring troughs may be permitted upon the Company's prior acceptance and shall have provisions for the Company's lock and seal and be accessible to the Company.

The breaking of seals or tampering with meters or unmetered wiring by unauthorized persons is prohibited. Attention is called to the criminal laws in the states where service is rendered, which make such unauthorized tampering a misdemeanor punishable by fine or imprisonment, or both.

7.1.7 Taps Ahead of Metering

Any tap made ahead of the main service billing meter(s), for emergency systems, control power for utilization equipment, etc. shall be specifically approved by the Company and shall be metered.

Exception: Control power for circuit breaker operation only shall be permitted to be unmetered.

7.1.8 Meter Relocation or Alteration

Whenever it is necessary to relocate an existing service entrance, service equipment, or meter board, the new installation shall be made by the Customer at its expense in accordance with these specifications. When the change is to be made, the Customer's electrician should make a definite time arrangement in advance, so the Company can have the new service drop or lateral and the meter available on completion of the Customer's electrical work. The service changes must be approved by the inspection authority having jurisdiction before the Company will connect to the Customer's equipment. No service entrance shall be left unmetered.

All Meter Locations Must Be Pre-Approved By The Company.

7.1.9 Group Metering

Where two or more meters are to be installed, all shall be grouped at one location. Prior to the Company setting the meters, each meter position shall be permanently marked by the Customer to clearly identify the space or apartment to which it is connected.

Where the Customer desires to provide either a meter center (multi-socket panel base assembly) or a pedestal style metering assembly, they must be approved by the Company prior to installation. See Section 7.2 for specifications. Meter centers and metering assemblies are limited to either 120/240 volts or 208Y/120 volts or 277/480 volts or 480Y/277 volts, with individual meters rated for either 100, 150, 200 or 320 amperes.

7.1.10 Emergency System Metering

Customer designated emergency system metering in most cases will be transformer rated. Consult the Company for specific guidance.

7.1.11 Shared Metering

In a multiple tenant building with individual metering, the house load requires a separate meter. The house load is that which is common to the property such as halls, entryways, outdoor lighting, building appliances, etc. and under the property owner's management. The Company shall be consulted in each case.

7.2 METER APPLICATIONS AND REQUIREMENTS 600 VOLTS AND LESS

The following tables are the Company's specified metering applications and requirements for services 600 volts and less.

Table 7.2-1 Meter Socket and Transformer-rated Meter Applications

<i>Note #</i>	<i>Service Type</i>	<i>Service Voltage</i>	<i># Phases</i>	<i>Service Size (Amps)</i>	<i># Wires</i>	<i># Meter Terminals</i>	<i>Hot / Cold Sequence</i>	<i>Manual Bypass Required</i>	<i>Figure #</i>
Self-contained									
	Residential	120/240	1	100 / 200	3	4	Hot	No	7.3-1
	Residential URD	120/240	1	200	3	4	Hot	No	7.3-2
	Residential 2-6 gang	120/240	1	150 each	3	4	Hot	No	7.3-7
1	Residential	120/240	1	400	3	4	Hot	Yes	7.3-3
2	Residential	120/208	1	100 / 200	3	5	Hot	No	7.3-4
3	Commercial	120/240	1	100 / 200	3	4	Hot	Yes	7.3-1
	Commercial 2-6 gang	120/240	1	200 each	3	4	Hot	Yes	7.3-7
1	Commercial	120/240	1	400	3	4	Hot	Yes	7.3-3
2	Commercial	120/208	1	100 / 200	3	5	Hot	Yes	7.3-4
2	Commercial - Network	120/208	1	200	3	5	Cold	Yes	7.3-4
	Commercial 2-6 gang	120/208	1	100 each	3	5	Hot	Yes	7.3-7
	Commercial	277/480	1	100	3	5	Cold	Yes	7.3-4
1	Commercial	277/480	1	400	3	5	Cold	Yes	7.3-3
	Commercial	208/120	3	200	4	7	Hot	Yes	7.3-5
1	Commercial	208/120	3	400	4	7	Hot	Yes	7.3-6
1	Commercial - Network	208/120	3	400	4	7	Cold	Yes	7.3-6
	Commercial	480/277	3	200	4	7	Cold	Yes	7.3-5
1 & 4	Commercial	480/277	3	400	4	7	Cold	Yes	7.3-6

January 2019

above 400A (non-self contained, metering transformers are used)								
	Residential	120/240	1	Above 400	Company Supplies Socket	Hot	N/A	7.4.1-1, -4
	Commercial	208/120	3	Above 400	Company Supplies Socket	Hot	N/A	7.4.1-1, -2, -4
	Commercial	480/277	3	Above 400	Company Supplies Socket	Hot	N/A	7.4.1-1, -2, -4
	Commercial - Network	208/120 480/277	3	400	Company Supplies Socket	Cold	N/A	7.4.1-3
Notes								
1	A 400A service with a class 320 meter and socket is limited to 320 continuous amperes load capacity - See Table 7.2-4 for rating requirements of service.							
2	5 th meter terminal is located in the 9:00 o'clock position and connected to the neutral.							
3	Where a non-standard 120V, 2 wire, 30A service is maintained, use 240V, 3 wire, 100A service and use 2 wire for load connection.							
4	This service (self-contained 480V class - 400A) shall be suitable for available fault current, see Table 7.2-2.							

Table 7.2-2 Self-contained Meter Socket Requirements

Req.	Self-contained Meter Socket Criteria
1	All meter sockets shall have independent test laboratory listing agency label certifying to ANSI/UL 414, ANSI C12.7, NEMA 250, NEMA Publication No. EL-17, and NFPA 70 (NEC).
2	All meter sockets shall be ringless and individual covers must have a hasp provision for the Company's seal.
3	All meter socket enclosures shall be outdoor NEMA 3R rated and withstand the ambient and environmental conditions where located. Meter facilities shall be protected from dust, moisture, corrosion, etc. (Some extreme conditions may require a minimum NEMA 4X rated enclosure.)
4	Overhead types shall have hub opening at top for top entry in meter socket or central wiring space of ganged sockets.
5	All meter sockets shall have adequate continuous duty and short circuit withstand ratings applicable for the service connection. Refer to Sections 5 and 9 and note following this table.
6	Jaw assembly shall permit use of "Mylar plastic disconnect sleeves" being applied over the blades of the watt-hour meter without cutting or mutilation of the insulator material.
7	100A and 150A rated meter socket jaw assemblies shall be compatible with Class 200 rated watt-hour meters.
8	Neutral position shall be bonded to the meter socket enclosure.
9	Bolted or lay-in type terminals and terminal blocks shall have Allen or hex head terminal screws rated for 150 inch-pounds (17 Newton-meters) tightening torque minimum.
10	Underground (bottom entry) types and central wiring space of ganged types shall have 3/8 inch (10 mm) diameter stud terminals capable of pulling tensions up to 400 lbs. (1.78 kN) force. <ul style="list-style-type: none"> ✓ The Customer shall install crimp type or approved spring-type compression connectors. Mechanical (bolted) connectors are not acceptable. ✓ Parallel conductors (2 maximum) attached to stud terminals shall be terminated with stackable crimp type compression connectors (or spacers approved for the purpose). ✓ Completed connection requires two threads of the stud exposed.
11	Connection temperature rating is preferred at 90 degrees C and insulation material to be rated 600V and arc track resistant.
12	The meter socket meets the wire bending requirements within the enclosure and at terminations according to the NEC.
13	A manual, single handled By-Pass with locking jaw and safety arc shield is required for all commercial and 320A class residential applications.

January 2019
Note: Meter Socket Minimum Short Circuit Withstand Capability

Meter sockets shall have a minimum short-circuit withstand rating of 10,000 amperes rms symmetrical at 300 volts AC. The exceptions are 200 and 320 ampere-rated single or three phase meter sockets having short circuit ratings based on the use of an overcurrent protective device on a circuit capable of delivering not more than:

RMS SYM. AMPS, MAX.	MAX. OVERCURRENT PROTECTION, AMPS	VOLTS MAX.	RMS SYM. AMPS, MAX.	MAX. OVERCURRENT PROTECTION, AMPS	VOLTS MAX.
200,000	200 CLASS J or T FUSE	600	25,000	100 CIRCUIT BREAKER	240
100,000	400 CLASS J or T FUSE	600	22,000	1 ph. 125 CIRCUIT BREAKER	240
100,000	100 CLASS RK5 FUSE	600	18,000	200 CIRCUIT BREAKER	240
50,000	600 CLASS T (300V) FUSE	300	14,000	ANY CIRCUIT BREAKER	600
42,000	200 CLASS RK1 FUSE	480			

Table 7.2-3 General Self-contained Meter Socket Installation Responsibilities Checklist
The Company will:

- ✓ Designate Service and Meter Locations.
- ✓ Furnish and install service drop conductors to the point of connection and make final connection, except as permitted under Section 4.2.6 for residential overhead service upgrade projects.
- ✓ Install the meter.

Customer will:

- ✓ Furnish and install the service entrance conductors and equipment in accordance with the requirements of the National Electrical Code and the Company.
 - Use an approved oxide inhibiting compound on aluminum conductors (not on meter jaws).
 - Install expansion joint in underground conduit according to NEC Article 300 for underground served meter socket
- ✓ Make connections in meter socket trough.
 - Use approved compression connectors on stud-type underground line connections for URD type meter sockets.
- ✓ Install the meter socket on approved support according to Section 7.7.
- ✓ Obtain an electrical inspection certificate from a recognized electrical inspection authority.

Table 7.2-4: 320A Meter Socket Applications

Those applicants or existing customers applying for 400-ampere service at a delivery voltage of 120/240, 120/208 or 277/480 volts that propose to install a self-contained 320-ampere meter socket shall meet the following criteria:

- ✓ Group the Class 320 meter socket with an 80% derated main circuit breaker service equipment.
- ✓ Demonstrate as part of the municipal or third party inspection approval that the load side capacity is not more than 320-ampere continuous (see NEC Article 220).
- ✓ Customer designs resulting in higher calculated peak load current or using 100% rated main circuit breaker or fuses greater than 320 amperes will require an instrument transformer metered service.
- ✓ The Customer shall reserve space for a future instrument transformer meter cabinet, since any failure of the Company's self-contained meter due to loads exceeding 320 continuous amperes will require an upgrade to instrument transformer metering prior to re-energization.
- ✓ All 480 volt class self-contained metering installations shall be cold sequenced and include line side service equipment that allows the meter(s) to be de-energized by Company employees. Additional disconnects may be installed between the service equipment and each self-contained 480V meter as necessary for multiple metered applications.

Note: In all cases, the Company reserves the sole right to specify the final metering configuration based on the Customer's load characteristics and Good Utility Practice.

7.3 SELF-CONTAINED METER SOCKET INSTALLATIONS

Meter socket troughs shall not be used as junction boxes or wiring troughs for splices or taps. The Customer shall consult with the Company prior to meter trough installation when considering a meter installation using other than the preferred wiring configuration. The following illustrations are typical arrangements required for the applications and requirements specified in Section 7.2.

Figure 7.3-1 Typical Single Phase Residential or Commercial Meter Socket Connections 120/240 Volt, 3 Wire, 200 Ampere Maximum Continuous Duty

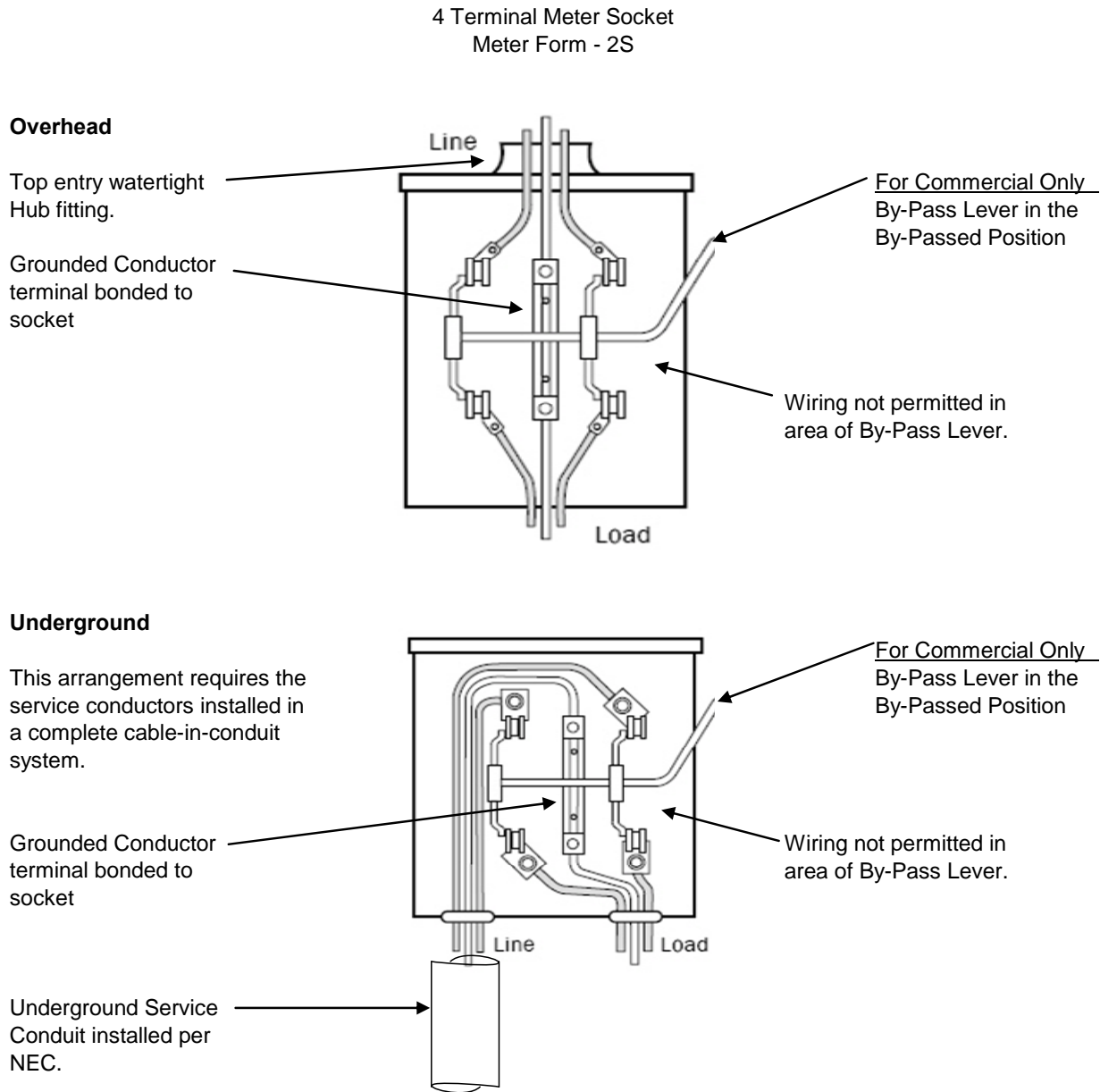

See Tables 7.2-1 through 7.2-3 for further details on application, requirements, and responsibilities.

January 2019

Figure 7.3-2 Typical Single Phase Residential URD Meter Socket Connection 120/240 Volt, 3 Wire, 200 Ampere Maximum Continuous Duty

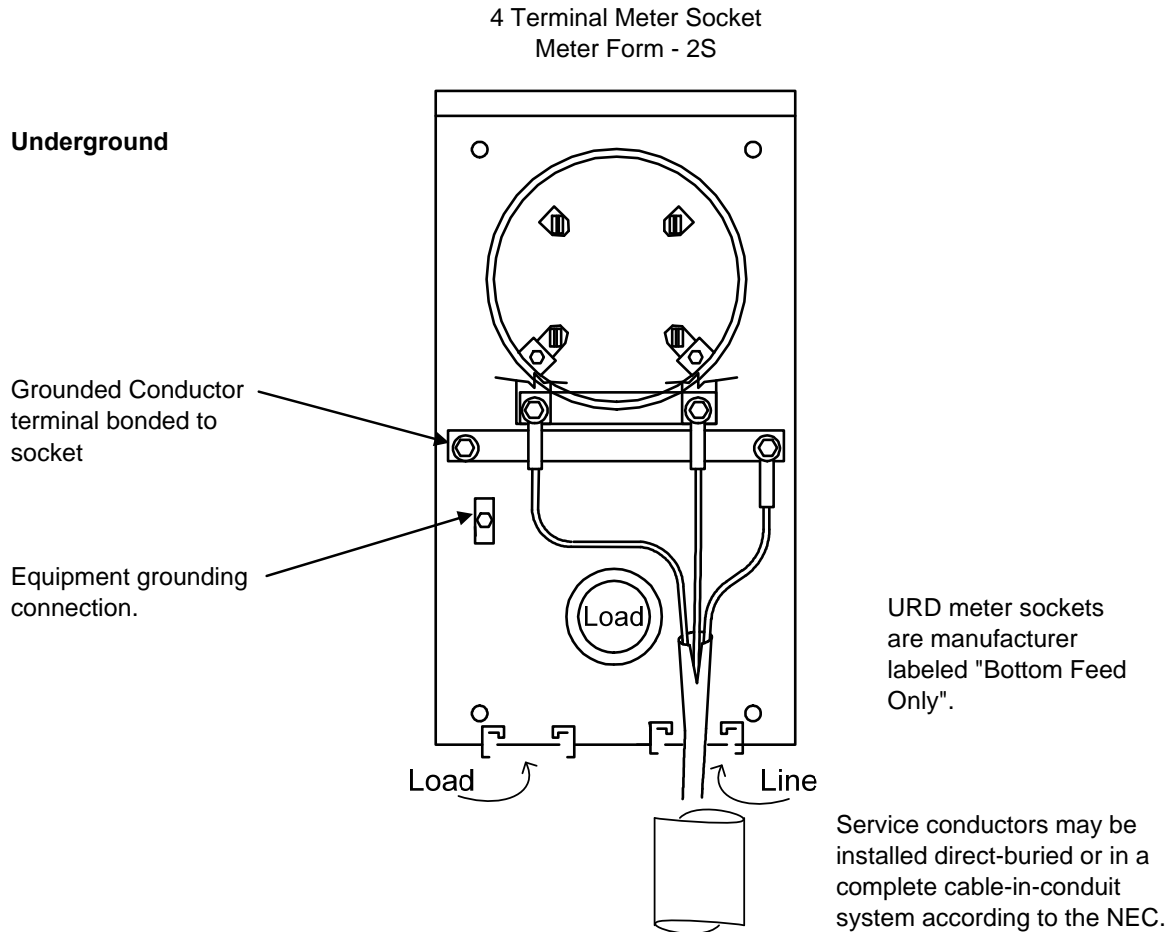

See Tables 7.2-1 through 7.2-3 for further details on application, requirements, and responsibilities.

January 2019

Figure 7.3-3 Typical Single Phase Residential or Commercial Meter Socket Connections 120/240 Volt or 120/208 Volt or 277/480 Volt, 3 Wire, 320 Ampere Maximum Continuous Duty

4 and 5 Terminal Meter Sockets
Meter Forms - 2S and 12S

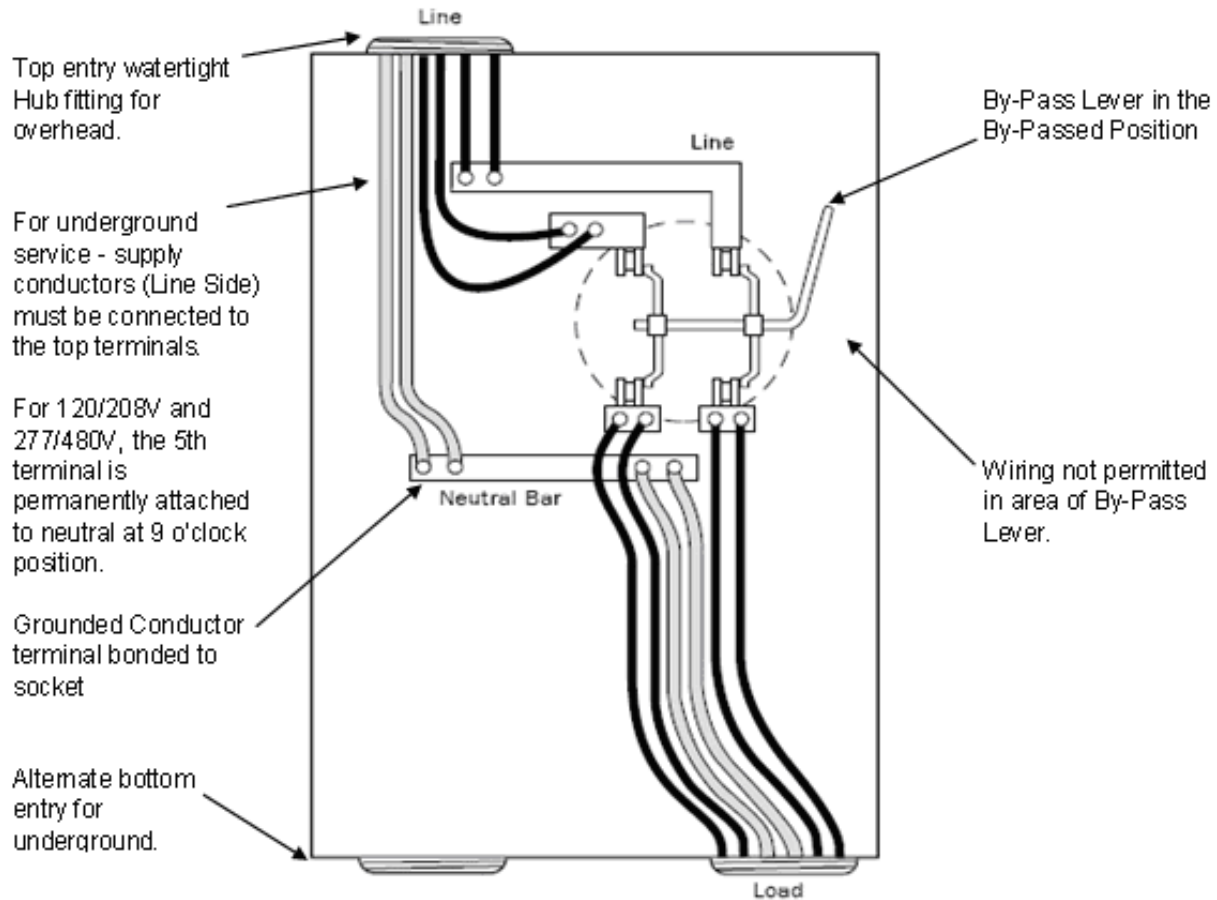

- ✓Applications: For Single phase 3 wire 120/240 volts or 120/208 volts or 277/480 volts 320 ampere continuous service (one meter installation).
- ✓Service entrance cable or service entrance conductors shall be installed according to the NEC. Side or rear entry (exit) not permitted. The preferred wiring for overhead installation is in the top of the meter socket and exiting the bottom. The preferred wiring for underground installation is in the bottom left side of the meter socket and exiting the bottom right side.
- ✓Underground service conductors for residential may be installed direct-buried or in a complete cable-in-conduit system according to the NEC. Conduit is required for commercial.

See Tables 7.2-1 through 7.2-3 for further details on application, requirements, and responsibilities.

January 2019

Figure 7.3-4 Typical Single Phase Residential or Commercial Meter Socket Connections 120/208 Volt and 277/480 Volt, 3 Wire, 200 Ampere Maximum Continuous Duty

5 Terminal Meter Socket
Meter Form - 12S

Overhead

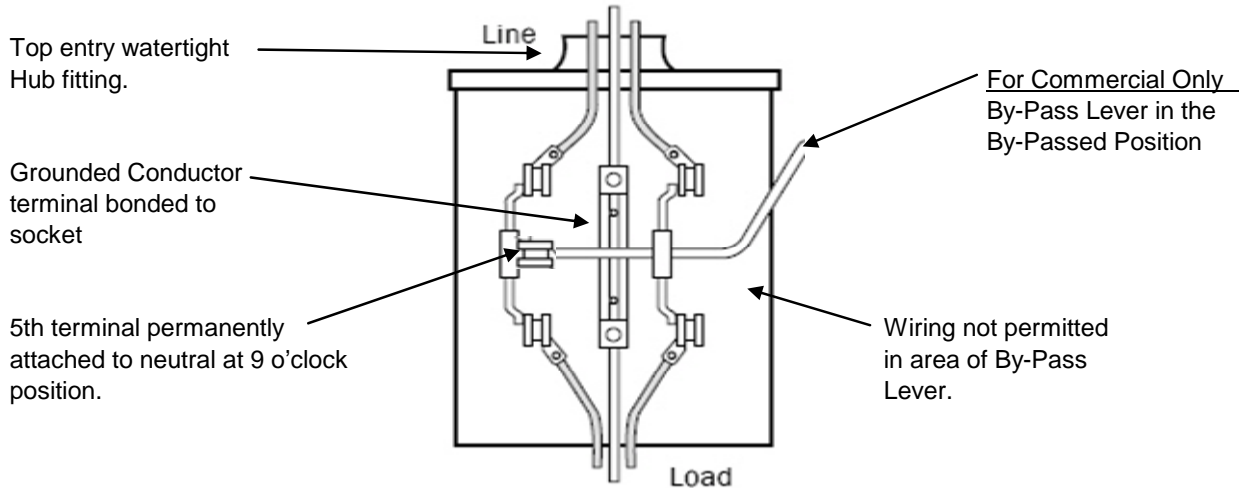

Underground

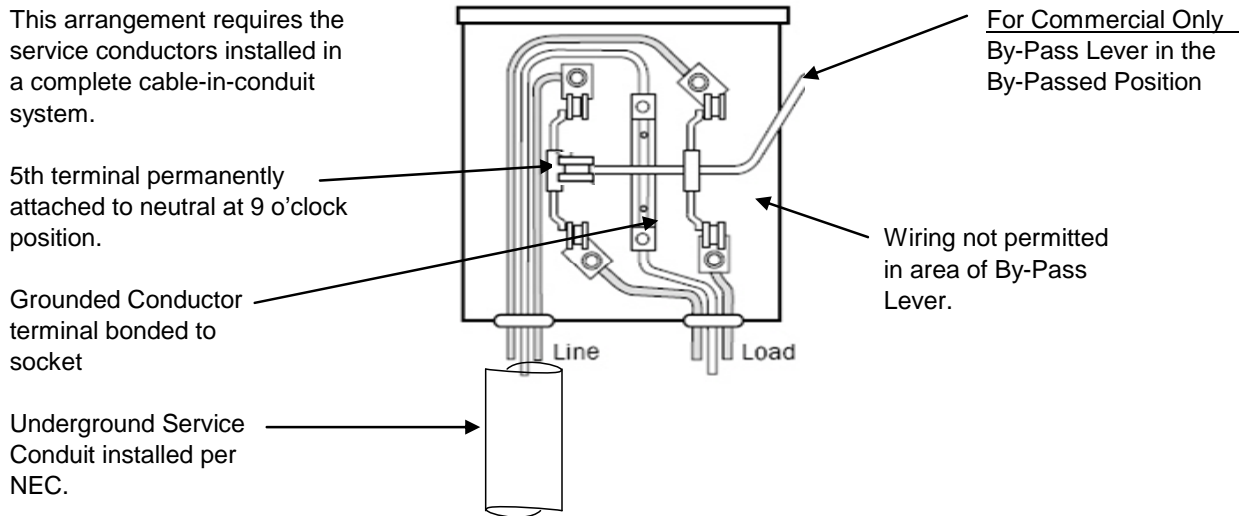

All 480 Volt class self-contained meters shall be cold sequenced.

See Tables 7.2-1 through 7.2-3 for further details on application, requirements, and responsibilities.

January 2019

Figure 7.3-5 Typical Three Phase Commercial Meter Socket Connections 208Y/120 Volt and 480Y/277 Volt, 4 Wire, 200 Ampere Maximum Continuous Duty

7 Terminal Meter Socket
Meter Form - 16S

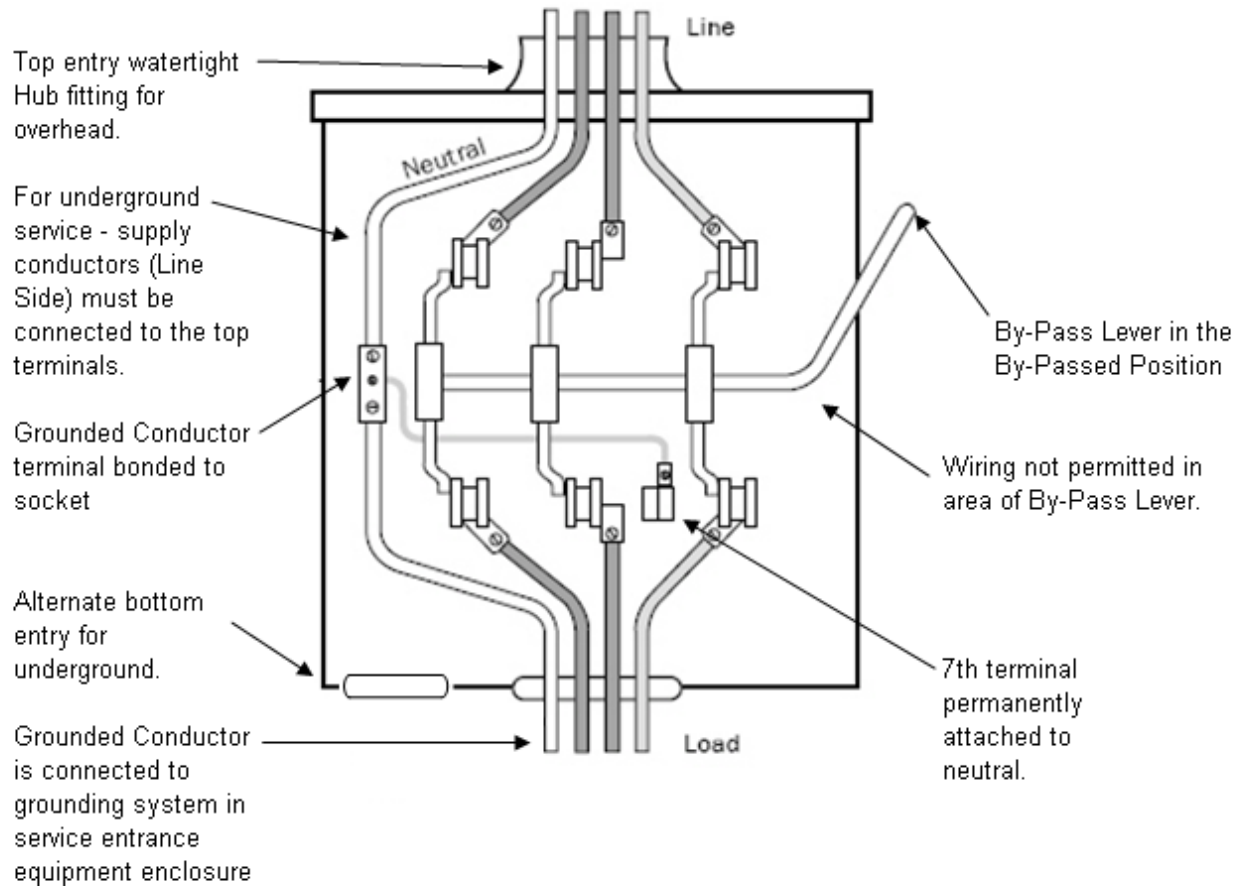

Service conductors shall be installed in a complete cable-in-conduit system according to the NEC.

All 480 Volt class self-contained meters shall be cold sequenced.

See Tables 7.2-1 through 7.2-3 for further details on application, requirements, and responsibilities.

January 2019

Figure 7.3-6 Typical Three Phase Commercial Meter Socket Connections 208Y/120 Volt and 480Y/277 Volt, 4 Wire, 320 Ampere Maximum Continuous Duty

7 Terminal Meter Socket
Meter Form - 16S

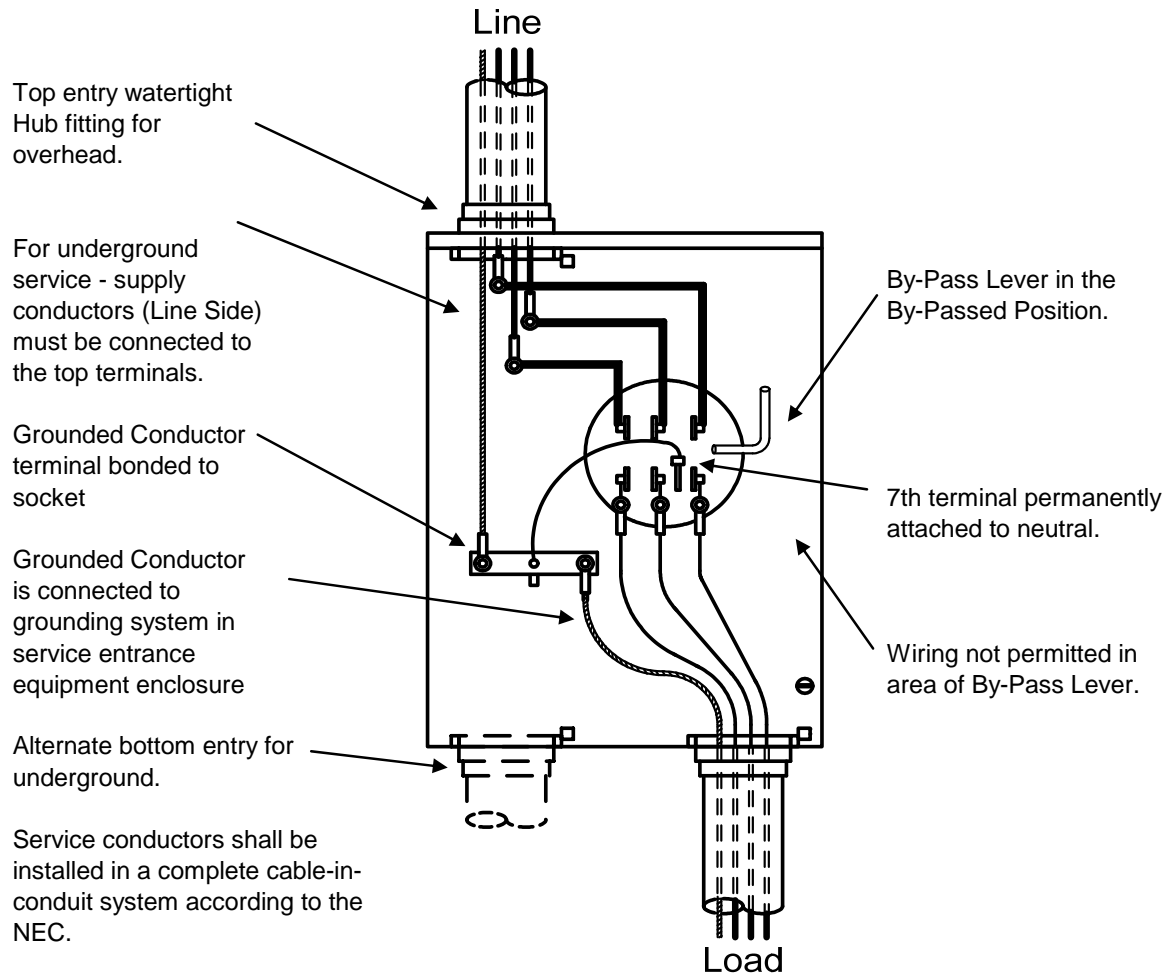

- ✓ Applications: For three phase 4 wire 208 wye/120 volts or 480 wye/277 volts 320 ampere continuous service (one meter installation).
- ✓ Service entrance cable or service entrance conductors shall be installed according to the NEC. Side or rear entry (exit) not permitted. The preferred wiring for overhead installation is in the top of the meter socket and exiting the bottom. The preferred wiring for underground installation is in the bottom left side of the meter socket and exiting the bottom right side.
- ✓ Cold sequence metering arrangement is required if single-phase 277/480V or 3 phase 480Y/277V service.

See Tables 7.2-1 through 7.2-3 for further details on application, requirements, and responsibilities.

January 2019

Figure 7.3-7 Typical Single Phase Residential or Commercial 2-to-6 Ganged Meter Socket Connections 3 Wire, 120/240 Volt 150 Ampere and 120/208 Volt 100 Ampere, Maximum Continuous Duty per Position

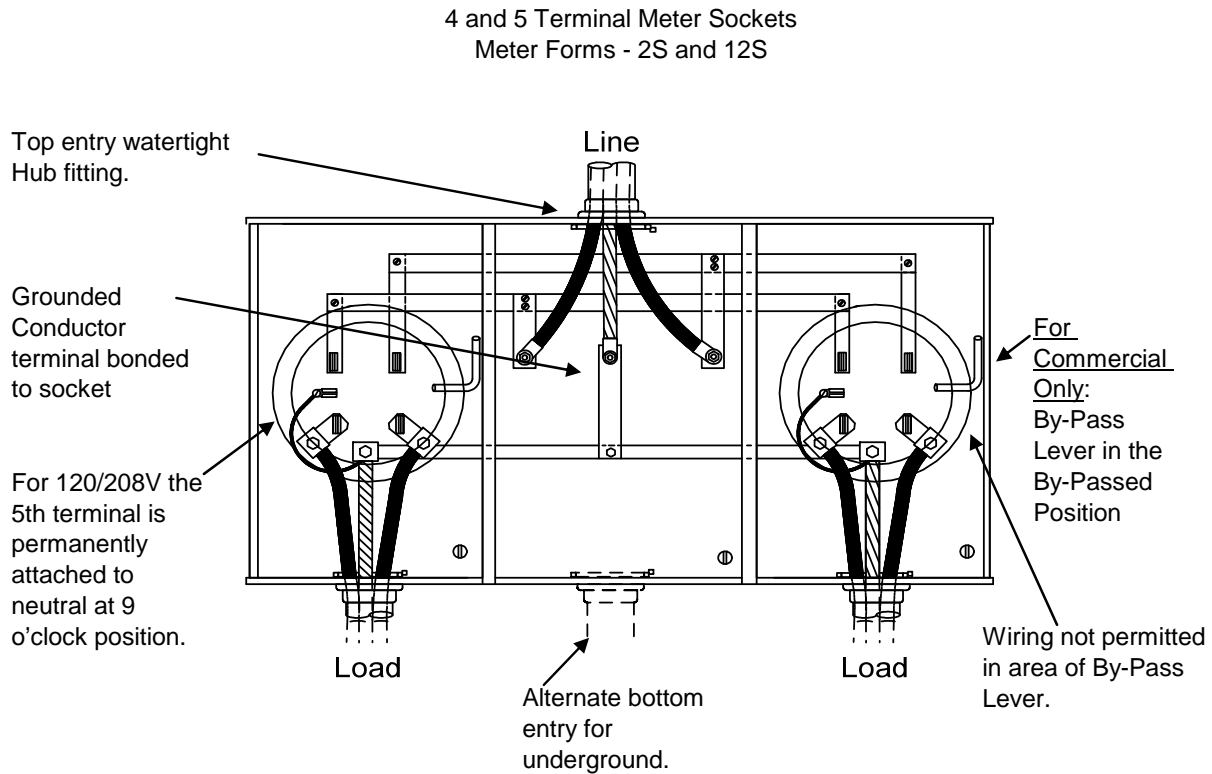

- ✓ One-hole pad crimp-type or spring type compression connector for 3/8"(10mm) stud size to be furnished and installed by customer.
- ✓ Fifth terminal supplied by Customer. Connected to socket trough neutral stud by Customer with #10 AWG copper insulated conductor.
- ✓ Multimeter channel cannot be modified for additional positions.
- ✓ Connect grounded circuit conductor to service equipment neutral bus.
- ✓ Grounding system shall be installed according to NEC requirements.
- ✓ Load side to Customer's service equipment. If the meters serve another building or structure, service equipment shall be adjacent to the meters.
- ✓ For underground service, service conductors for residential may be installed direct-buried or in a complete cable-in-conduit system according to the NEC. Conduit is required for commercial.

See Tables 7.2-1 through 7.2-3 for further details on application, requirements, and responsibilities.

Figure 7.3-8 Typical Residential or Commercial Service Pedestal Single Phase Service 120/240 Volt 200 Amp and 120/208 Volt 100 Amp, 3 Wire

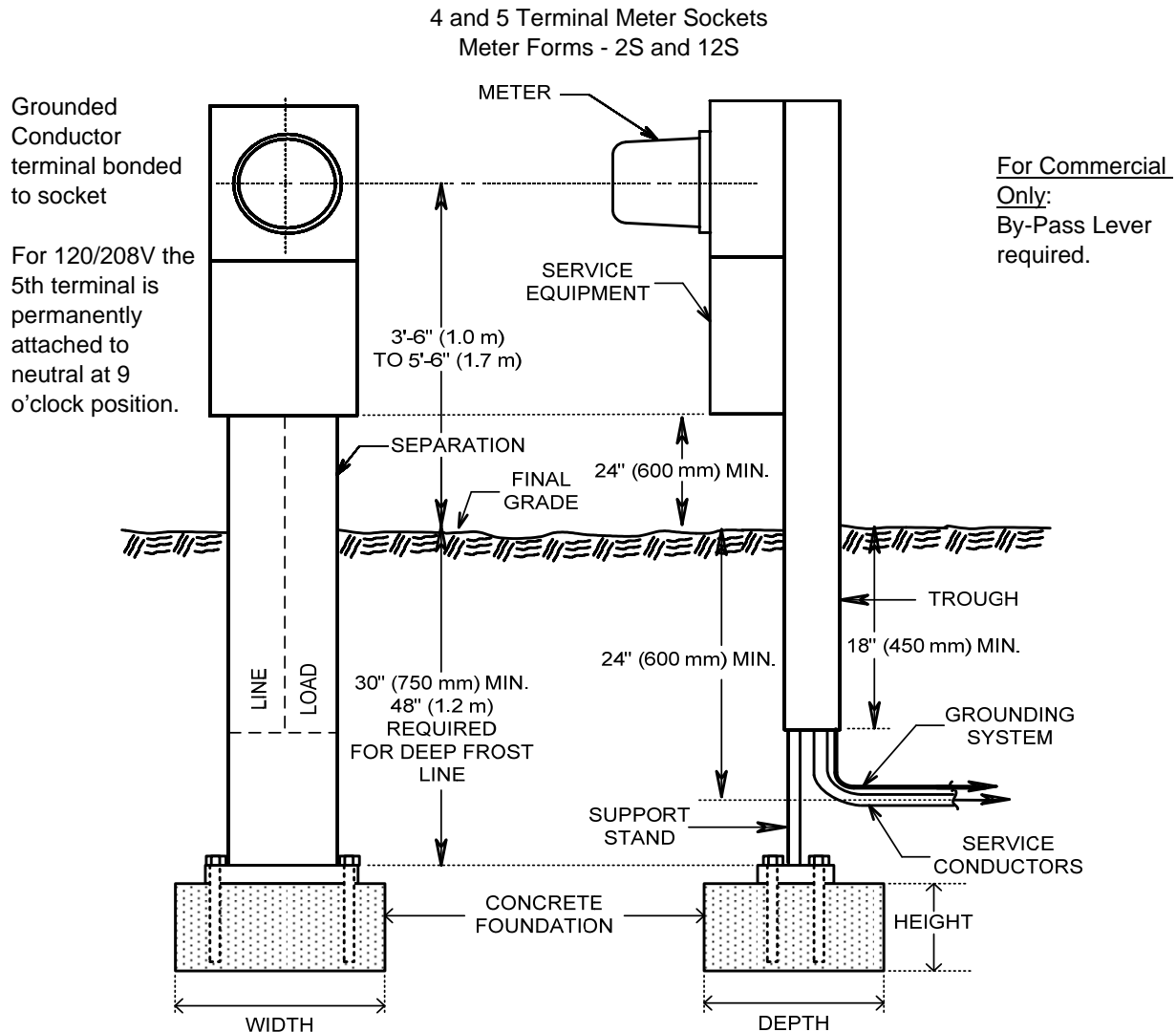

- ✓ Applications include mobile homes, residential, and small commercial service.
- ✓ Grounding system installed as required by NEC.
- ✓ Underground service conductors to handhole or transformer by Customer for residential may be installed direct-buried or in a complete cable-in-conduit system according to the NEC. Conduit is required for commercial. Metered and unmetered conductors shall not occupy same raceway. Six inch (150mm) minimum cable separation between line and load cables in common trench.
- ✓ Concrete footing minimum dimensions shown for a single pedestal [28" (710mm) wide, 18" (450mm) deep, 12" (300mm) high] greater size footing required for multiple or larger pedestal units.
- ✓ Service pedestal to be furnished, installed and maintained by Customer. Pedestal shall meet Table 7.2.-2 for meter socket section. Pedestal location shall be accepted by the Company.
- ✓ Other service supports may be considered. Prior approval is required from the Company.

See Tables 7.2-1 through 7.2-3 for further details on application, requirements, and responsibilities.

Figure 7.3-9 Typical Residential or Commercial Meter Center (more than six meters) Single Phase and Three Phase Service 120/240 Volt 200 Amp and 120/208 Volt 100 Amp, 3 Wire and 208Y/120 Volt, 4 Wire

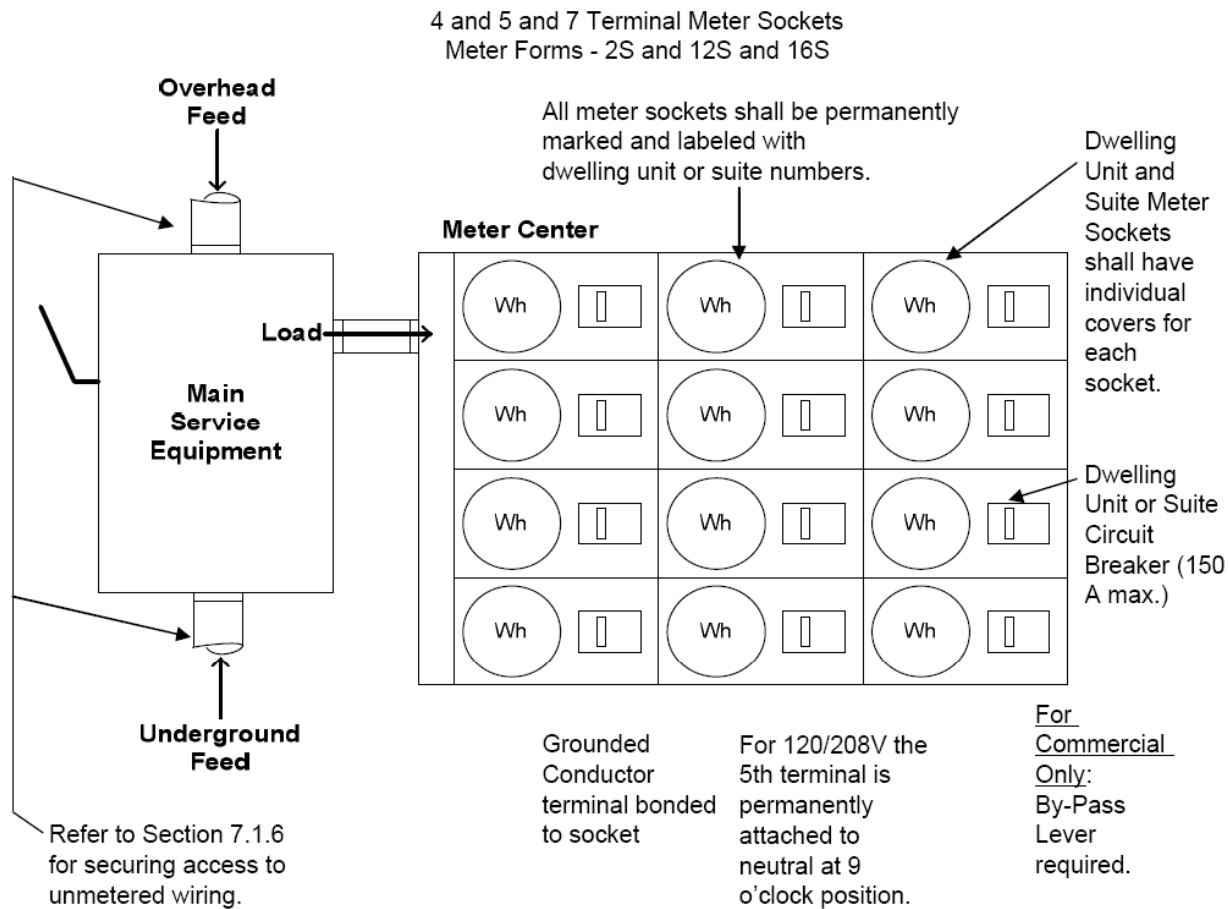

- ✓ Bond metallic conduit in accordance with NEC Article 250.
- ✓ See Section 4 for service entrance conductors in approved conduit and sized according to the NEC.
- ✓ Meter board/support construction according to Section 7.7 and securely mounted, at least 6" (150mm) from top of meter board to ceiling or beam.
- ✓ Fifth terminal is needed at 9 o'clock position for 120/208 Volt 3wire installations.
- ✓ Meter centers may be mounted vertically or horizontally, depending upon manufacturer's specific design. Raintight where located outdoors.
- ✓ 6'-0" (1.8m) maximum above floor or final grade to center of top row of meters.
- ✓ 2'-0" (600mm) minimum above floor indoors and 2'-6" (750mm) minimum above final grade outdoors to center of bottom row of meters.

See Tables 7.2-1 through 7.2-3 for further details on application, requirements, and responsibilities.

Meter Center (more than six meters) should be located 3'-0" minimum from a sidewall or structure. All meter locations must be pre-approved by The Company.

January 2019

Figure 7.3-10 Typical Mobile Home and Recreational Vehicle Park Meter Socket Applications

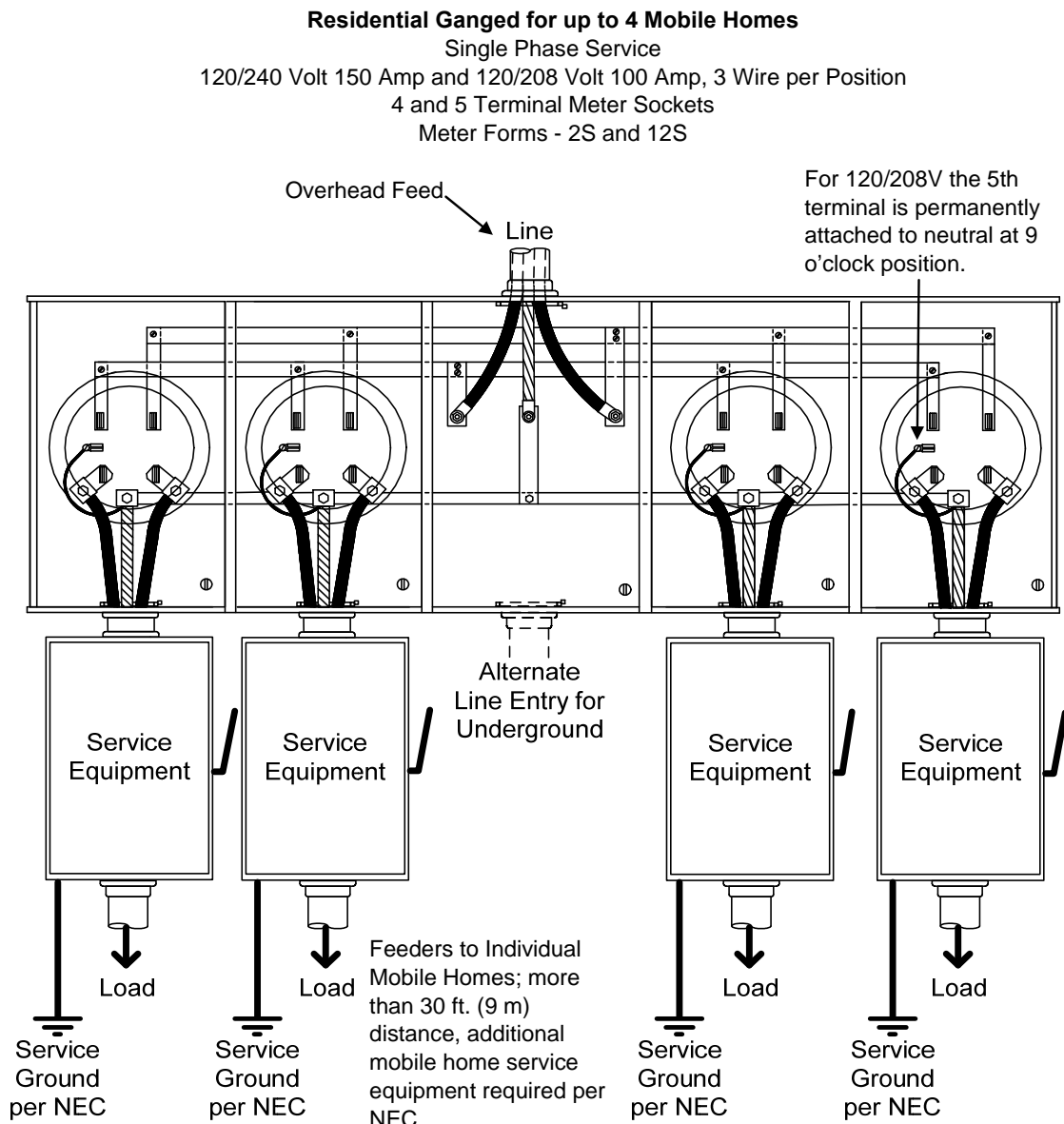

- ✓ Service arrangement to be used for existing overhead served mobile home parks or new groups of up to four mobile homes where URD rules do not apply and where single meter or grouped indoor meter installation is not practical.
- ✓ See Section 4 for service entrance conductors in approved conduit and sized according to the NEC. If metallic conduit, bond conduit in accordance with the N.E.C.
- ✓ Install service entrance ground in accordance with N.E.C.
- ✓ Outdoor meter support materials and construction according to Section 7.7 and securely mounted.
- ✓ Meter sockets are supplied by the Customer and the Company will supply meters.
- ✓ All meter sockets shall be permanently marked and labeled with individual mobile homes served.

See Tables 7.2-1 through 7.2-3 for further details on application, requirements, and responsibilities.

For metered service pedestal serving a mobile home underground, see Figure 7.3-8.

January 2019

7.4 TRANSFORMER-RATED METERING 600 VOLTS AND LESS, 400 AMPS AND ABOVE

7.1.1 Instrument Transformers and Enclosures

The Company will specify and furnish the quantity and type of all current and voltage transformers for revenue metering. The Customer shall install all instrument transformers except those for pad-mounted metering. **Enclosures shall be approved by the Company** but furnished and installed by the Customer. All transformer enclosures must have facilities for Company locks. Instrument transformer cabinets shall not be used as junction boxes or for branch circuit wireways. The preferred entry and exit wiring method for metering transformer cabinets are from the side not the top or bottom. The Customer shall consult with the Company prior to transformer-rated meter cabinet installation when considering a meter installation using other than the preferred wiring configuration. In some cases, the Company may choose to supply the instrument transformers to be installed by the switchgear manufacturer. Contact Liberty Utilities Meter Department for submittal and approval of metering enclosures or cabinets.

The following illustrations are typical transformer-rated metering arrangements required for the applications and requirements specified in Section 7.2.

Figure 7.4.1-1 Typical Commercial CT Cabinet Secondary Metering Installation
120/240 volt Single-phase
208Y/120 volt & 480Y/277 volt Three-phase
400 A through 800 A

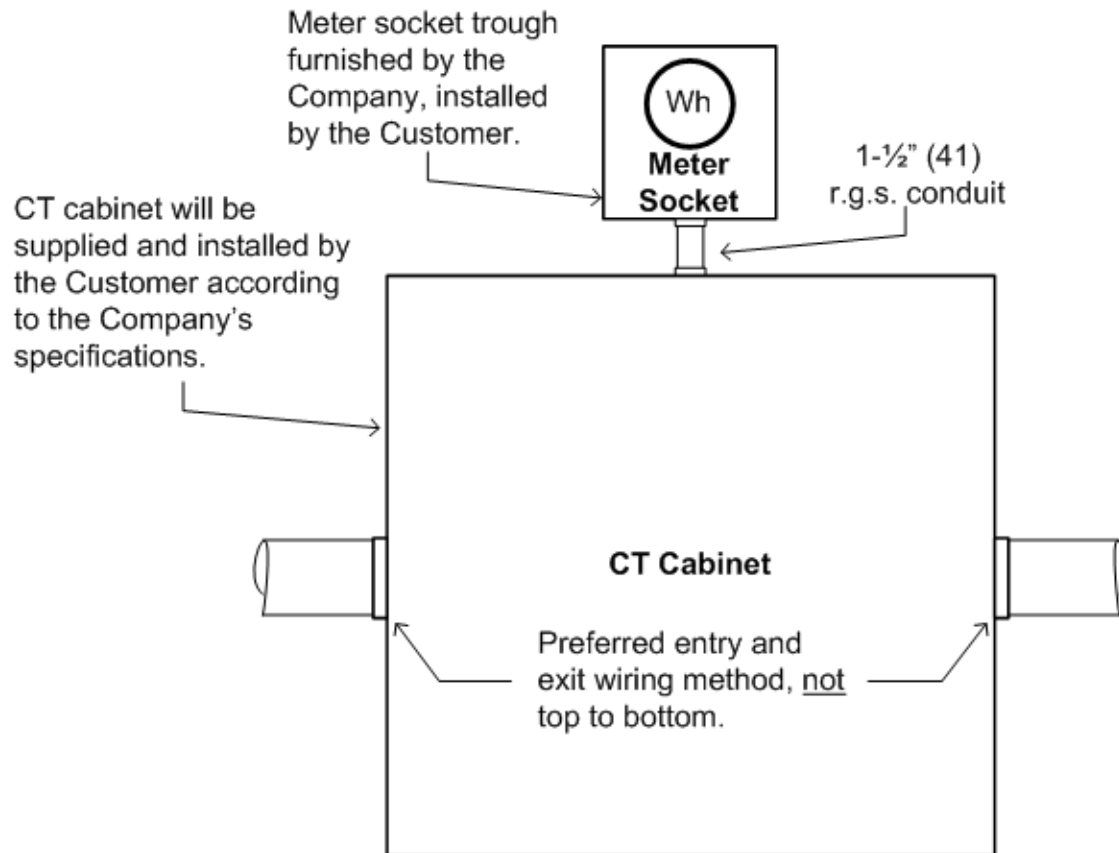

Customer-owned Metering CT Cabinet Requirements:

- ✓ Minimum Size - 36" (900 mm) wide x 36" (900 mm) height x 10" (250 mm) deep
- ✓ Rolled Lip Cover
- ✓ Permanently installed hinge pins, removable cover in open position
- ✓ Padlock and Sealing Provisions
- ✓ NEMA 3R Rainproof Enclosure Indoor/Outdoor Use
- ✓ Listed by Independent Recognized Testing Laboratory
- ✓ Mounting Provisions for Field-installed Instrument Current Transformers
- ✓ Preferred entry and exit wiring on sides; not top and bottom
- ✓ Grounding Stud

See Tables 7.2-1 through 7.2-3 for further details on application, requirements, and responsibilities.

Figure 7.4.1-2 Typical Indoor Commercial Installation Two to Six Meter Service Entrance 800A Maximum From Overhead Line

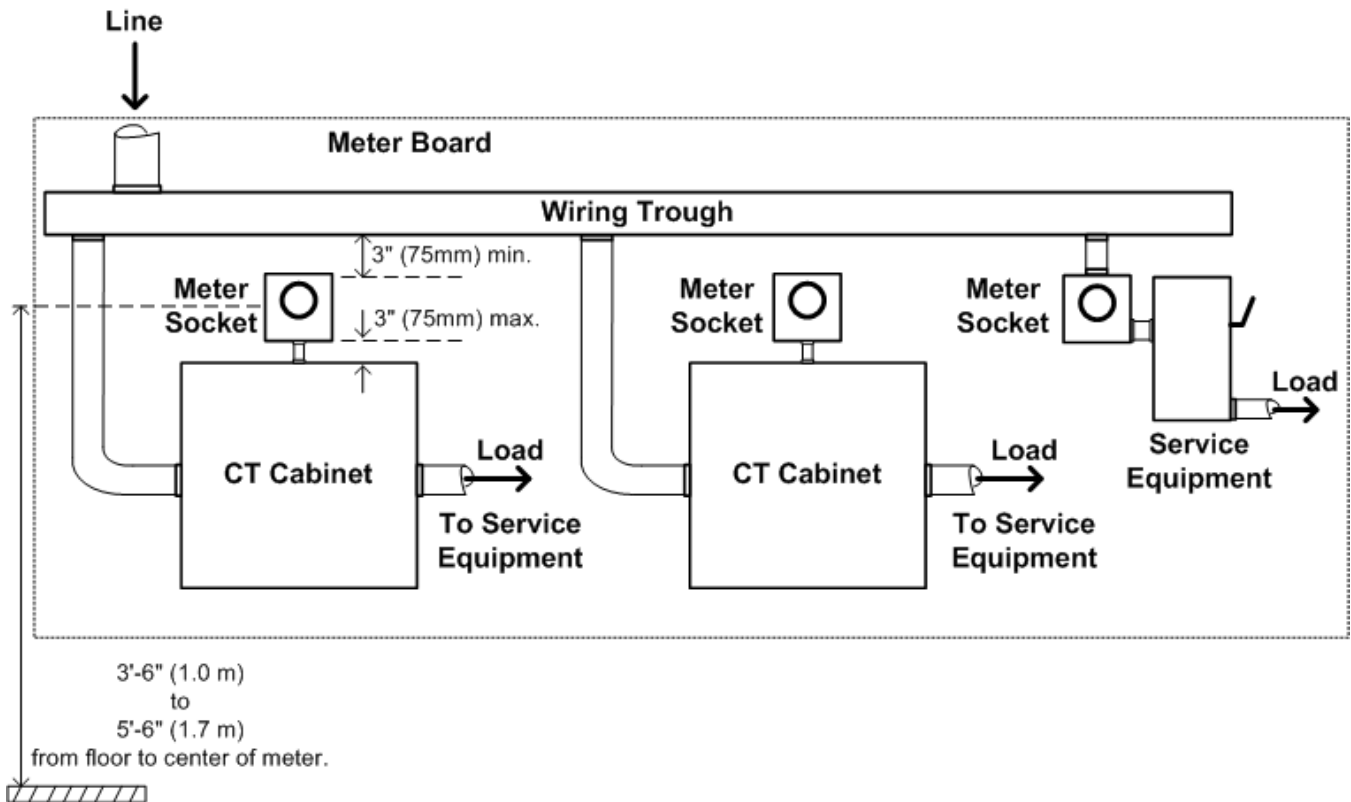

- ✓ See Section 7.4.1 and Figure 7.4.1-1 for metering CT cabinet requirements, 400A to 800A.
- ✓ 1-1/2" (41) rigid galvanized steel conduit required between CT cabinet and meter socket.
- ✓ See Sections 7.2 and 7.3 for appropriate self-contained meter socket installations below 400A. Cold sequence installation required for 480V class self-contained meter sockets.
- ✓ Wiring trough in accordance with NEC requirements and includes provisions for locking or sealing by the Company.
- ✓ See Section 7.7 for Meter Board requirements.

See Tables 7.2-1 through 7.2-3 for further details on application, requirements, and responsibilities.

Current Transformer (CT) Enclosure 120/240V Single Phase-208Y/120V & 480Y/277V 3 Phase

Millbank or approved equivalent

400A-800A	10" D x 36" W x 36" H with P series blank panel cat# 363610-CT3R
800A-1200A	12" D x 48" W x 48" H with P series blank panel cat# 484812-CT3R

Figure 7.4.1-3 Typical Indoor Commercial Installation One Meter Service Entrance from Network or Radial Underground Line Three-Phase, 4 Wire, 208Y/120V, 400A

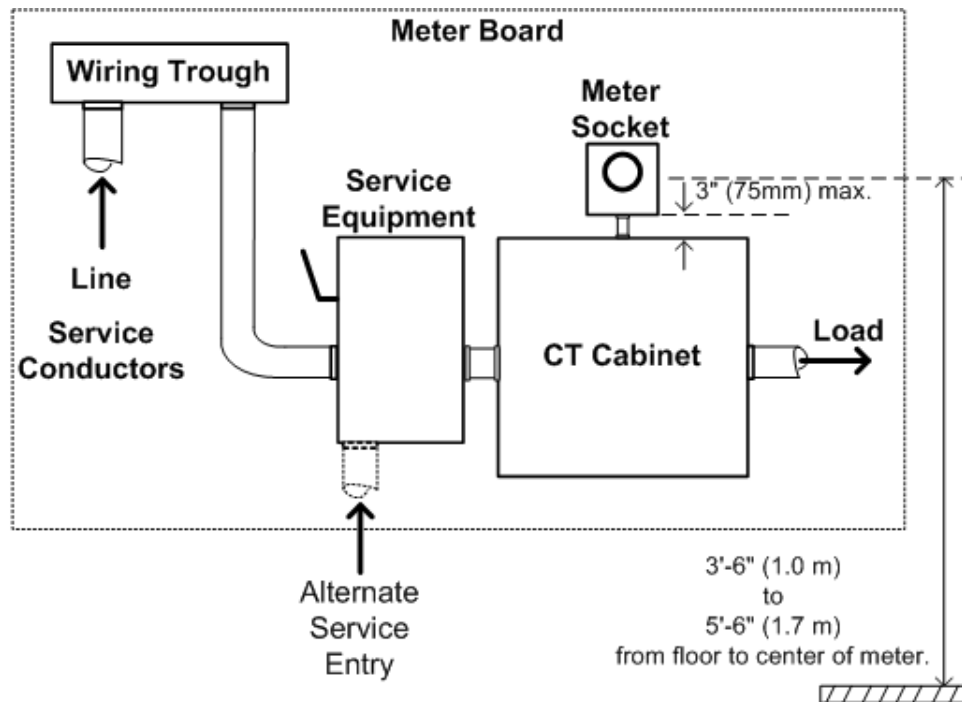

- ✓ See Section 7.4.1 and Figure 7.4.1-1 for 400A metering CT cabinet requirements.
- ✓ 1-½" (41) rigid galvanized steel conduit required between CT cabinet and meter socket.
- ✓ Wiring trough in accordance with NEC requirements and includes provisions for locking or sealing by the Company.
- ✓ See Sections 4 and 5 for underground service connection requirements (radial underground line and network services).
- ✓ See Section 7.7 for Meter Board requirements.

See Tables 7.2-1 through 7.2-3 for further details on application, requirements, and responsibilities.

Figure 7.4.1-4 Typical Outdoor Service Pole Installation Single-Phase, 3 Wire, 120/240V for Loads 72 to 100kVA Demand or Three-Phase up to 800A From Overhead Line

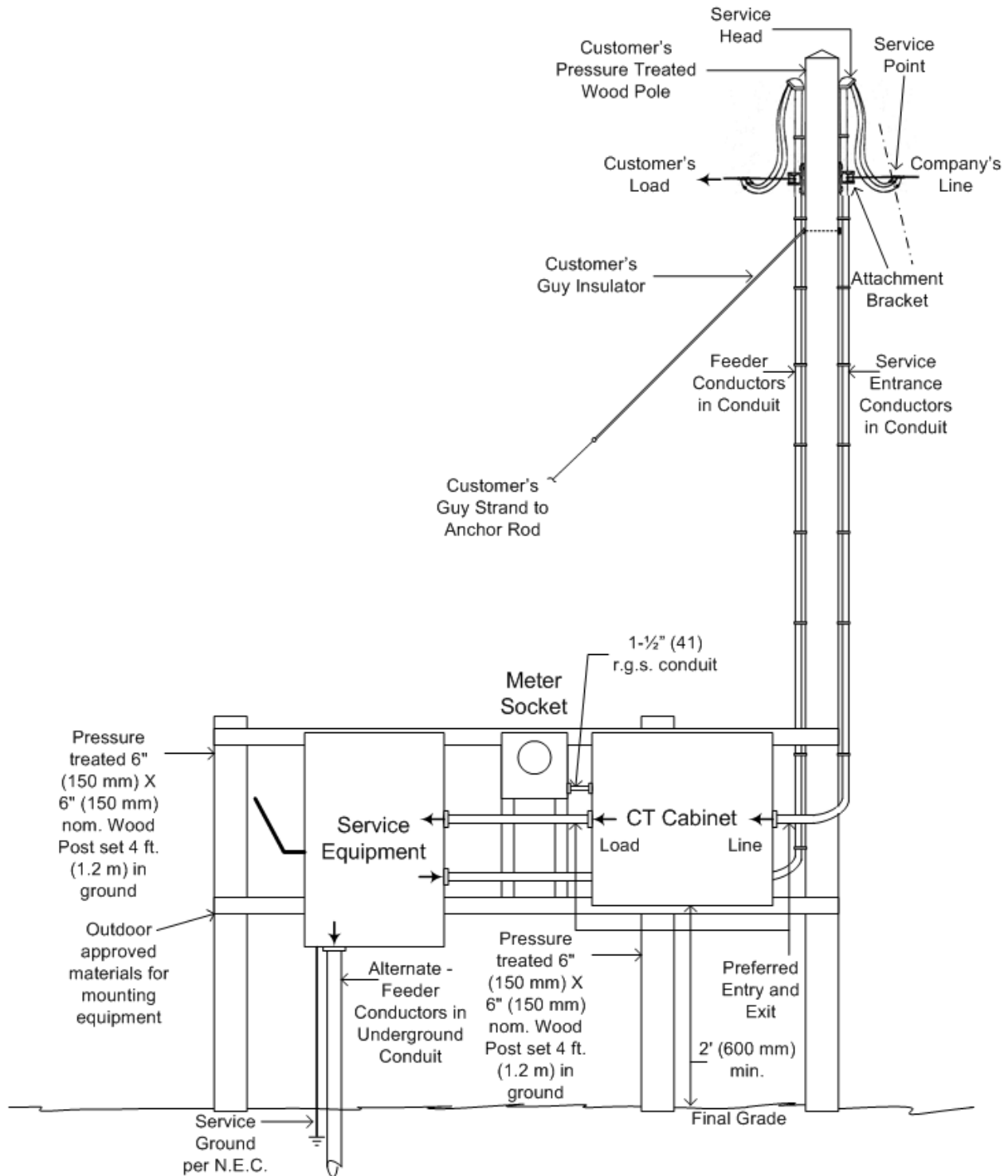

- ✓ See Section 7.4.1 and Figure 7.4.1-1 for metering CT cabinet requirements, 400A to 800A.
- ✓ See Section 7.7 for Meter Support requirements.

See Tables 7.2-1 through 7.2-3 for further details on application, requirements, and responsibilities and Section 4 for overhead service connection requirements.

January 2019

7.4.2 Meter Sockets

The Company will furnish meter sockets for use with instrument transformers. Meter socket enclosures shall be installed by the Customer at the Company's specified location and wired by the Company. Where the metering is on a pad-mounted transformer, the Company will both install and wire the meter socket.

7.4.3 Metering Sequence

All metering equipment shall be installed on the line side of the service disconnecting means (**Hot Sequence**) with the exception of network services. Network services shall have metering equipment installed on the load side of the service disconnecting means (**Cold Sequence**).

7.4.4 Instrument Transformer Secondaries

The Customer will furnish and install a 1-1/2 inch (41) rigid galvanized steel conduit between the instrument transformer enclosure and the meter socket which shall be in the same location within sight. The use of conduit body fittings (condulets) with removable covers is not acceptable. The maximum distance between the instrument transformers and the meter shall be 50 feet (15 meters). Secondary wiring will be furnished and installed by the Company.

7.4.5 Pad-mounted Transformer Service Metering

At the Company's option where a single customer is supplied from a 300 kVA or larger pad-mounted transformer, bushing current transformers will be used. The meter socket will be mounted on the outside of the secondary voltage compartment of the pad-mounted transformer.

7.4.6 Metal-Enclosed Free-Standing Service Cubicles Rated 600 volts or Less (Secondary Voltage Installations)

7.4.6.1 General

The Customer shall provide the Company with equipment specifications prior to ordering any equipment. All components of equipment shall conform to the latest editions of all applicable ICEA & ANSI standards, and the Company recommends that all equipment be certified and approved by a laboratory testing organization such as UL, ETL, CSA, etc.

7.4.6.2 Metering Sequence

Refer to Section 7.4.3 and see Figure 7.4.6.2-1.

Figure 7.4.6.2-1: Instrument Transformer Metering Sequence - Service Cubicles Rated 600 volts

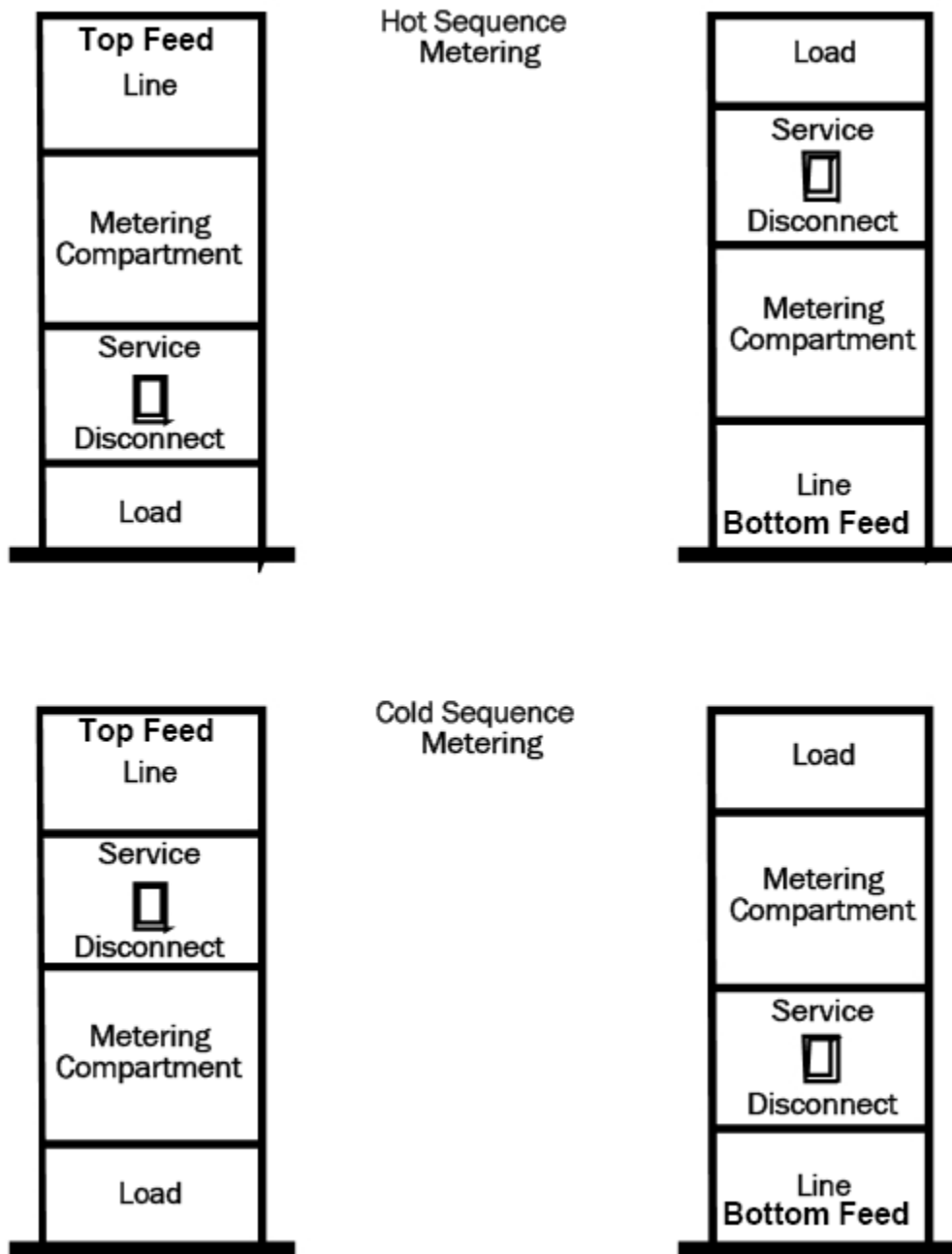

Note: Cold sequence metering is required on the network system.

7.4.6.3 Unmetered Supply Conductors

Compartments enclosing unmetered supply conductors shall be accessible through hinged doors or removable panels provided with hardware for the installation of locks as specified by the Company.

7.4.6.4 Meter Location

A meter location shall be provided that is large enough for mounting a meter socket supplied by the Company. The meter socket shall be installed at the location assigned by the Company, as near as practical to the instrument transformers. The maximum distance between meter and instrument transformers shall not exceed 50 feet (15 meters). A continuous run of rigid metal conduit shall be provided by the Customer between the meter socket and the instrument transformers.

January 2019

7.4.6.5 Customer's Auxiliary Equipment

The connection of the Customer's auxiliary transformer for heat, light and receptacle(s) installed at the meter panel location and elsewhere within the Customer's switchgear, shall be on the load side of the Company's instrument transformers.

7.4.6.6 Metering Transformer Equipment Compartment

A separate properly barriered compartment, completely isolated within the equipment, shall be provided for the installation of current and voltage transformers of a type and rating as specified and furnished by the Company. This compartment shall be designed so that each of the transformers can be readily removed or changed without disturbing the others after installation and shall be solely accessible by the Company. (See Figure 7.4.6.7-1.) The Customer shall have provisions in the metering transformer compartment for the Company's connection of the metering potential neutral to the service equipment neutral bus.

Where the metering transformer compartment is located in an unheated area or building, provisions shall be made for heating the compartment to prevent condensation. The Customer shall maintain a minimum 10 feet (3 m) unobstructed clearance in front of the instrument transformer compartment door. The compartment shall be solely accessible by the Company, any section-to-section openings for through bus shall be as small as phase to ground clearance will allow. Phase buses shall be mechanically independent of the instrument transformers and the transformers shall be not part of the bus support system. Removable bus bar sections shall be provided by the Customer to permit installation and removal of current transformers. Silicon-bronze bolts and stainless steel nuts and washers shall be provided by the Customer for connection of the Company's current transformers.

Access to the metering compartment shall be through a full door hinged to permit horizontal swing of at least ninety degrees and provided with hardware for locking as specified by the Company.

No equipment other than Company owned metering equipment shall be installed in the compartment.

Transformers shall be installed in each position so that the rating and polarity marks are readily and safely readable.

January 2019

**Figure 7.4.6.6-1: Metering Instrument Transformer Compartment in Service Cubicles Rated 600V
Hot Sequence Metering**

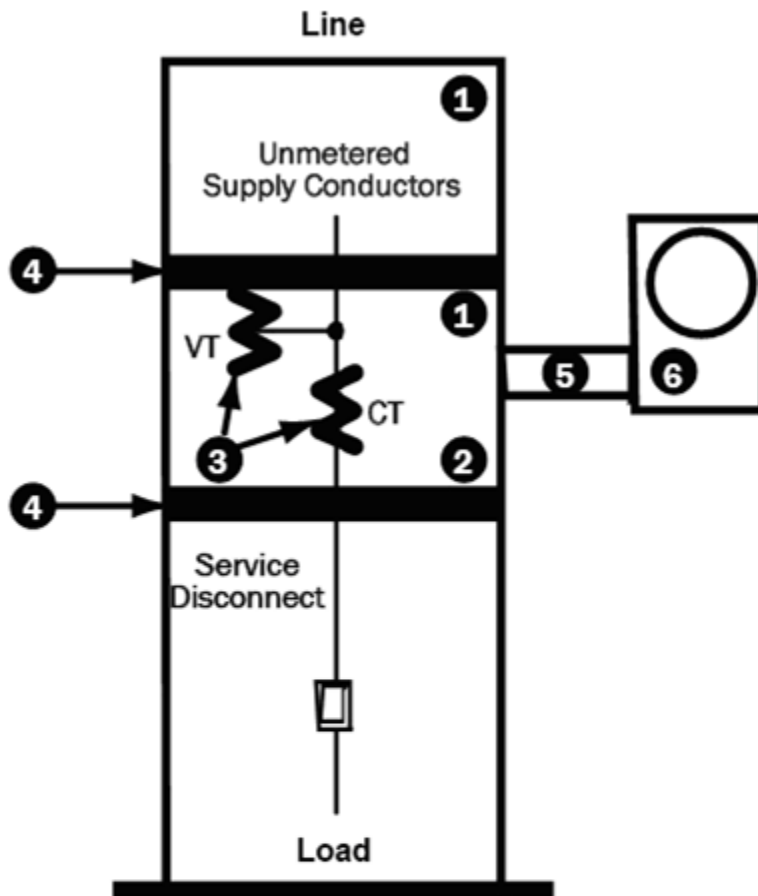

Notes:

1. Compartments lockable.
2. Instrument transformer compartment.
3. Metering transformer supplied by the Company.
4. Insulating barriers.
5. 1-1/2" (41) Rigid Galvanized Steel conduit.
6. Meter socket mounted adjacent to service cubicle.
7. A connector shall be provided in the metering transformer compartment for purposes of connecting the metering potential neutral to the incoming service neutral.

7.4.6.7 Voltage Transformers

In general, voltage transformers will be supplied for metering services where the supply is 240 volts or greater. Primary connections for the voltage transformers shall be made on the supply side of the current transformers. Instrument transformer-rated metering 400 amperes and greater, do not require voltage transformers.

7.5 METERING ABOVE 600 VOLTS

Where the service exceeds 600 volts, the Customer shall consult the Company. In such cases, the Company will furnish additional information about the metering requirements.

7.6 METERING PULSE SIGNALS

At the Customer's request, the Company will install at the Customer's expense at the point of metering a source of kWh pulses so that the Customer may monitor load/demand for the purpose of load control. Time pulses will not be provided. The Company is not responsible for customer equipment failure for the loss of pulse signals.

Analog signal provisions are subject to the Company's applicable tariff; consult the Company for application.

7.7 METER BOARDS AND SUPPORTS

7.7.1 Meter Mounting

All meters shall be durably and securely mounted in a true vertical position on a flat surface.

7.7.2 Approved Materials

The Customer shall provide and mount a meter support for each installation.

Materials acceptable for all installations are:

- 3/4 inch (19 mm) marine grade plywood.
- Galvanized steel slotted framing channel (Kindorf, Unistrut, Superstrut, or approved equal) 12 gauge zinc coated steel, with holes, 1-1/2-inch (38 mm) h X 3/4-inch (19 mm) w X (length = width of associated meter socket), two required, one for top, one for bottom. Zinc coated steel bolts 1/4-inch (6 mm) dia. X 3/4-inch (19 mm) long with nut and washer, total of four required, two for top, two for bottom of meter socket.
- 1-1/2-inch (38 mm) thick minimum pressure treated wood (approved outdoor ground contact rating minimum) with zinc coated lag bolts, two required, one for top, one for bottom of each board secured to structure.
- Masonry or solid brick wall of building with corrosion inhibiting protection applied to the meter enclosure.

Painted and/or treated 3/4-inch (19 mm) plywood board is acceptable in dry indoor locations. The support shall provide a clear space for mounting the Company's metering devices. Provision should be made for air circulation behind the meter board to inhibit "dry rot".

Where a meter support is required or used in an outdoor location, material used shall be protected from the effects of weather.

Irregular surfaces require provisions for flat support of meters. Meter boards are the preferred installation, alternatively, the building structure sub-surface may be used and the siding trimmed around the meter without interference of knockouts and meter cover.

Where service connection is made to the building, the meter shall be mounted on that building.

An outdoor manufactured meter pedestal as specified in Section 7.3 is also an approved meter support method.

8.0 MOTORS and CONTROLLERS

8.1 GENERAL

It is important that the Company be consulted concerning the type of electric service available to insure correct application (phase and voltage) of the motor to be used. The correct application of motors is the Customer's responsibility. Motors should be sized to tolerate possible phase voltage unbalance, must be of a type that uses minimum starting current, and must conform to the Company's requirements and the applicable electrical code as to wiring, kind of equipment, and control devices. Starting current limitations are prescribed for conventional motorized equipment rated in horsepower and air conditioning or heat pump equipment rated in Btu/hr. Cases not covered in this section shall be referred to the Company.

8.2 SINGLE PHASE MOTORS

8.2.1 120 Volt Supply

Motors with ratings of one half ($\frac{1}{2}$) horsepower or less and window-type air conditioning units whose running-load current does not exceed $7\frac{1}{2}$ amperes, with not more than four (4) starts per hour and with a locked-rotor current not exceeding 50 amperes, may be connected to 120 Volt supply. Motors having a full load running current of more than $7\frac{1}{2}$ amperes but less than 12 amperes, and conforming to the above locked-rotor current limitations, may be connected to a 120 Volt branch circuit only if such branch circuit supplies the one unit and does not supply lighting units or other appliances. It is strongly recommended that units drawing more than $7\frac{1}{2}$ amperes full-load running current be connected to 240 or 208 Volt circuits. Generally, motors larger than 5 HP should be three phase but the Company may require that single-phase motors be used where three-phase service is not readily available.

8.2.2 208 or 240 Volt Supply

Motors with ratings larger than one half ($\frac{1}{2}$) but less than six and one-half ($6\frac{1}{2}$) horsepower will be regularly supplied at 208 or 240 volts, provided the locked-rotor current does not exceed the values given in Table No. 8.6-1. In predominantly residential areas, and for small commercial installations, the Company should be consulted before installing motors with ratings of three (3) horsepower or larger.

8.2.3 Maximum Locked-Rotor Currents

Single-phase motors supplied from combined light and power secondary systems shall not have locked-rotor current values in excess of those shown in Table No. 8.6-1. Motors having locked-rotor current values in excess of those shown in the table shall be equipped with starters that will limit the current to the values specified. Domestic laundry equipment with operating cycles and electrical characteristics as currently available are considered acceptable.

Motors that start more than four (4) times per hour are an exception to the above and may cause interference to other customers. Automatically (frequently) started motors for general use, such as motors for refrigerators, oil burners, and similar devices, shall not have a locked-rotor current exceeding 23 amperes at 120 volts or 19 amperes at 240 volts. For multi-motored devices arranged for starting of motors one at a time, the locked-rotor current limits shall apply to the individual motors.

8.2.4 Single-Phase Motors on Three-Phase Service

Where single-phase motors are supplied from a 3-phase service, they shall be properly balanced across the three (3) phases.

8.3 THREE-PHASE MOTORS

8.3.1 Size of Motors

In order that the proper capacity may be available to supply the load, the Company should be advised of the motors to be installed. In predominantly residential areas, the Company should be consulted before installing 3-phase motors with ratings over five (5) horsepower.

8.3.2 Maximum Locked-Rotor Currents

Three-phase motors supplied from a combined light and power secondary system shall not have locked-rotor current values in excess of those shown in Table No. 8.6-2. Starting compensators are ordinarily required for 3-phase motors seven and one-half (7½) horsepower and larger. Exceptions to this practice will be allowed to the extent local distribution facilities permit. Motors having current values in excess of those shown in the table shall be equipped with starters, which will limit the current to the values specified. Increment start motors must have not less than a one-half-second interval between steps. The Company should be consulted concerning the installation of three-phase motors ten (10) horsepower or larger and must be consulted on motors larger than 15 horsepower.

8.4 MOTOR PROTECTION

Protective devices shall be installed on the load side of the meter.

8.4.1 Overload Protection

All motors should be properly protected against overload, including overloads caused by low voltage conditions.

8.4.2 Protection Against Single-Phase Operation

Three-phase motors shall be protected against the possibility of the failure of any one phase of the supply circuit. Three overcurrent (overload) units shall be used, one in each phase, unless the motor is protected against single-phase operation by other approved means. It is the Customer's responsibility to protect three phase motors against the possibility of single-phase operation.

8.4.3 Reverse Phase Protection

On motors for passenger and freight elevators, cranes and hoists, and other equipment where reversal or direction of rotation might cause property damage or injury, approved reverse phase relays together with circuit breakers, or equivalent devices, should be used on all three phase installations so that the motor circuit will be opened in the event of loss of any phase or phase reversal. The operation of this relay and associated circuit breaker should be instantaneous and should be such that the circuit cannot be re-energized until the normal phase relations are restored.

8.4.4 Undervoltage Protection

Motors that cannot be safely subjected to full voltage at starting, or would start on return of normal voltage after an interruption and endanger life or property, shall be provided with automatic undervoltage protection. Such protective device shall ensure that with either no voltage or undervoltage, the motor will be disconnected from the line and the starter will be returned to the "off" position. Where continuous operation of motorized equipment is essential, motor controllers should be arranged to allow motors to operate through a transient no voltage condition lasting for 1/2 second. The Company shall be consulted where problems of this nature may be encountered.

8.5 MOTOR-STARTING REQUIREMENTS

8.5.1 Objectionable Voltage Variation

Momentary fluctuation of the circuit voltage occurs each time a motor is started on the circuit. Where this effect is pronounced, a visual disturbance or lighting flicker may be observed by the Customer or

January 2019

other Customers served from the same system. In extreme cases, the motor itself may have difficulty starting.

8.5.2 Current Inrush Limitation

To suppress objectionable voltage variations and maintain proper service to the Customer and its neighbors, it is necessary to set maximum permissible limits to the current drawn from the service during each step of a motor-starting operation, based upon the frequency of starts. These limits are designed to cover typical cases and the Company gives no warranty that particular conditions may not later require a change.

The specific motor-starting current limitations stated in Section 8.6 or furnished by the Company indicate the maximum allowable increases in current on the line side of the motor-starting device at any instant during the starting operation.

These limitations do not restrict the total current that can be taken by the motor, but may require that this total be built up gradually, or in steps during starting. Where a step-type starter is used, an appreciable time must be allowed on each step and the current increase of each step shall not exceed the imposed limitation. Closed transition between starting steps is required.

When motors are started in a group instead of individually, the starting current limitations apply to the group and not the individual motors.

8.5.3 Favorable Locations

There are locations on the Company's system where starting currents larger than specified above can be permitted. These locations are on services from network systems, which supply large loads or where special conditions exist. The Company shall be consulted to determine whether larger starting currents per step will be permitted for a specified installation.

8.5.4 Company Notification of 3 HP Single Phase and 10 HP Three Phase Applications

The Company shall be advised before any single phase motor 3 HP (equivalent 25,000 Btu/Hr.) or larger, or any three phase motor rated 10 HP (equivalent 75,000 Btu/Hr.) or larger is purchased and/or installed by a Customer. The information to be given the Company shall include:

- Largest HP
- Rated Voltage
- Rated PF
- Is Motor started under load?
- Type and characteristics of starter employed, if any
- Motor application (i.e. sawmill, stone crusher, elevator, air conditioner, etc.)
- Single phase or three phase
- Locked Rotor indicating Code Letter
- Frequency of motor starting and inrush current surges.
- Type and characteristics of starter employed, if any

8.6 MAXIMUM PERMITTED STARTING CURRENT

These tables are based on not more than four (4) starts per hour with long periods of continuous operation under maximum load conditions. Consult the Company if these conditions cannot be met.

The maximum starting currents permitted for a single phase and three-phase conventional motorized equipment rated in horsepower and for air conditioning or heat pump equipment rated in Btu/Hr. are:

Table 8.6-1 - Single Phase Motor Starting Current

Service Voltage	Max. Starting Current Per Step Max. Four Starts Per Hour	Max. Equiv. Rating of Air Conditioner or Heat Pump Btu/Hr.
120 volts	50 amperes	10,000
208 or 240 volts	60 amperes for 2 HP motor	20,000
208 or 240 volts	80 amperes for 3 HP motor	25,000
208 or 240 volts	Residential use - Consult Company. Commercial use - 120 amperes for 5 HP to 6.5 HP.	40,000

Table 8.6-2 - Three Phase Motor Starting Current

Service Voltage	Max. Starting Current Per Step Max. Four Starts Per Hour	Max. Equiv. Rating of Air Conditioner or Heat Pump Btu/Hr.
208 volts	100 amperes up to 5 HP motor	40,000
208 volts	130 amperes for 7-1/2 HP motor	50,000
208 volts	160 amperes to 10 HP motor	75,000
208 volts	230 amperes for 15 HP motor	150,000
480 volts	50 amperes up to 5 HP motor	40,000
480 volts	65 amperes for 7-1/2 HP motor	50,000
480 volts	80 amperes for 10 HP motor	75,000
480 volts	115 amperes for 15 HP motor	150,000

9.0 TRANSFORMER INSTALLATIONS ON CUSTOMER PREMISES

9.1 GENERAL

The Company may require installation of its transformers and other line equipment on the Customer's property. Customer shall provide suitable space, vaults, foundations or pads, conduit and enclosures as required by the Company. Customer shall provide satisfactory access at all times to the space, enclosures, or vaults for the Company to install, or remove, operate and maintain its equipment. Consult the Company for transformer installations in network, UCD, and URD areas.

9.2 INSTALLATIONS

One of the following general transformer installations may be used for services rated below 600 volts:

9.2.1 Cluster Mounted Overhead Transformers

9.2.1.1 Recommended

Where:

- the Company's system is a primary supply voltage,
- the required transformation does not exceed 3-50 kVA transformers for 208Y/120 volts, or 3-50 kVA transformers for 480Y/277 volts, and
- aesthetics are not of prime concern.

Note: At the Company's sole discretion, request for overhead service above 200A at 480Y/277 volts or above 400A at 208Y/120 volts may be served by the Company's overhead secondary service conductors. **However, demand of 150kVA or more is generally preferred to be supplied by a pad mounted transformer service.** The Company shall discuss service arrangements with the Customer or Applicant accordingly.

9.2.1.2 Company Furnishes

The Company will furnish, install, own and maintain:

- the primary service lateral including transformer pole, equipment, transformers, and
- one overhead service drop.

See Section 4 for service limitations, allocation of service line cost, and service drop requirements.

9.2.1.3 Customer Furnishes

The Customer shall provide:

- property on which to erect the terminal pole for the cluster mounted transformers, and
- the necessary right-of-way for the overhead primary circuit including guying.

9.2.2 Outdoor Single Phase Pad Mounted Transformer

9.2.2.1 Recommended

Where the length of the underground service lateral would be excessive.

9.2.2.2 Provisions:

The installation provisions and costs shall be in accordance with the Company's filed tariffs in the state of New Hampshire. See Section 4 for the underground primary service lateral and secondary service conductor connection provisions to single-phase pad mounted transformer installations.

January 2019

Table 9.2.2-1 Company and Customer Outdoor Single Phase Pad Mounted Transformer Provisions

State	Company furnishes, installs, owns and provides maintenance for:	Customer furnishes, installs, owns and provides maintenance for:
NH	<ul style="list-style-type: none"> transformer box pad foundation an outdoor pad mounted transformer ground grid 	<ul style="list-style-type: none"> property on which to construct the transformer foundation outdoor pad mounted transformer foundation excavation bollards, if required by the Company

9.2.2.3 Installation Method

- For pad mounted transformer location considerations and requirements, refer to the Company's ESB 759B.
- The Customer's underground service conductors approved for direct burial installed according to the NEC shall extend at least 10 feet (3.0 m) and be coiled within one foot (300 mm) of transformer for connection by Company.
- All connections, permanent or temporary, at the Company's transformer shall be made by the Company. The Company will not permit this connection to be made by others.
- Refer to the following figures for typical outdoor Single-Phase Pad Mounted Transformer installation requirements.

See Section 4 for service limitations, allocation of service lateral cost, and service lateral cable installation requirements.

9.2.3 Outdoor Three Phase Pad Mounted Transformer

Refer to the Company's Electric System Bulletin No. 759B for outdoor three-phase pad mounted transformer installation requirements.

9.2.4 Transformer Vault in Non-Network Area

Contact Liberty Utilities' Customer Care Account Manager for indoor three-phase vault type transformer installation requirements.

9.3 AVAILABLE FAULT CURRENT

For equipment rating purposes, the following tables list the maximum fault currents available at the Company's transformer secondary terminals. These fault currents are based on the lowest impedance of transformers the Company procures and on infinite supply impedance on the primary side. Customer motor or parallel generator contributions and customer service conductor impedances are not included in figures given. Consideration for future load growth and subsequent transformer change-out may require initial installation of service equipment to have a larger fault current interrupting rating to ensure its suitability according to the NEC. Any costs associated with changes to Customer-owned equipment shall be borne by the Customer.

9.3.1 Network Services

Not available in Liberty Utilities' Electric Supply System.

9.3.2 Single Phase Transformers

Table 9.3.2-1 Single Phase Transformers Available Fault Current

kVA 1 ϕ Unit Transformer Rating	amperes RMS Symmetrical 240 Volt
25 & below	10,500
50	13,900
75	20,900

January 2019

100	27,800
167	46,400

9.3.3 Three Phase Overhead Transformers
Table 9.3.3-1 Three Phase Overhead Transformer Available Fault Current

3 - 1 ϕ Units	kVA		amperes Symmetrical Fault Current	
	Total 3 ϕ Bank		208Y/120 volts	480Y/277 volts
3-10	30		10,000	----
3-25	75		20,900	10,000
3-50	150		27,800	12,100
3-75	225		41,700	18,100
3-100	300		55,600	24,100
3-167	500		92,600	40,100
3-250	750		138,800	60,200
3-333	1,000		----	80,200
3-500	1,500		----	120,300

9.3.4 Three Phase Pad Mounted Transformers
Table 9.3.4-1 Three Phase Pad Mounted Transformer Available Fault Current

3 ϕ Units Pad Mounted	kVA		amperes Symmetrical Fault Current	
			208Y/120 volts	480Y/277 volts
75			20,900	10,000
150			34,700	15,100
300			69,400	30,100
500			92,600	40,100
750			41,700 *	18,100 *
1,000			55,600 *	24,100 *
1,500			----	36,100 *
2,000			----	48,200
2,500			----	60,200

* Size interrupting rating for largest fault current the service could expect.

10.0 DISTURBANCES AND POWER QUALITY

10.1 GENERAL

Customers with equipment that cause interference on the Company's system affecting other customers; shall, upon notice from the Company, take immediate remedial measures to avoid such interference.

Customers shall provide any facilities necessary to secure their own equipment against disturbances including but not limited to loss of phase, transients, voltage pulses or harmonic or carrier frequencies whether originating with their own equipment or elsewhere. These facilities shall be installed on the load side of the Customer's service equipment.

The Company is not responsible for disturbances resulting from weather conditions, acts of God, operations on the Company's system that are within good utility practice, or that may be generated by the operation of other Customer-owned equipment. The Company's goal is to provide a high quality service, and it will make every effort to work with its Customers to identify and to minimize the effects of these disturbances. If disturbances do occur, the Customer is advised to call the Company's Customer Service Center.

10.2 MOTORS

All motors connected to the Company's lines shall be of a type that shall have inrush current and other operating characteristics deemed acceptable by the Company. (See Section 8 for recommendations and guides on motors and controllers.)

10.3 DEVICES WITH INTERMITTENT HIGH CURRENT

The operation of large flashing signs over 10 kVA, arc welders, resistance welding machines, arc furnaces, dielectric and induction heaters, electric furnaces and boilers, heat pumps, X-ray equipment, motors connected to variable load machinery, reciprocating compressors, pumps, molding machines, rock crushers and similar apparatus having intermittent flow of large currents sometimes interferes with other users of the electric service and may require special facilities for satisfactory service. The Customer shall consult the Company in each case so that the type of electric service that will be supplied, the corrective equipment needed and other special precautions that must be taken will be mutually known factors before planning to use such apparatus. The Company in accordance with its applicable tariff may withhold connection to such loads which are considered detrimental to the service of other customers.

10.4 AUTOMATIC RECLOSING

Where the Company has installed on its facilities equipment for automatic reclosing after an interruption of power supply, it shall be the obligation of the Customer to provide at its expense:

- adequate protective equipment for all electrical apparatus of the Customer that might be adversely affected by the Company's reclosing equipment, and
- such equipment as may be required for the prompt disconnection of any apparatus of the Customer that might affect proper functioning of the Company's reclosing equipment.

10.5 ELECTRICAL INTERFERENCE

If at any time devices (i.e. carrier frequency systems, SCR controllers, etc.) installed by the Customer are causing interference on the electrical system of the Company, Customer, or to any other person, then upon notice from the Company, it shall be the responsibility of the Customer to install remedial equipment or take such other measures as may be necessary to reduce such interference to a tolerable level. Table 10.5-1 can generally be used as a guide for what are tolerable levels for current distortion. The Company, at its own discretion, may relax these limitations provided no interference is

January 2019

experienced. Table 10.5-2 for voltage distortion shall be adhered to. In certain cases a more stringent limitation may apply.

Table 10.5-1 Harmonic Current Limits for Non-Linear Loads at the Point-of-Common-Coupling (PCC) with Other Loads, at Voltages of 120V to 69kV

MAXIMUM HARMONIC CURRENT DISTORTION IN % OF FUNDAMENTAL						
I_{sc}/I_L	HARMONIC ORDER (ODD HARMONICS)					THD
	< 11	11 ≤ h < 17	17 ≤ h < 23	23 ≤ h < 35	35 ≤ h	
< 20*	4.0	2.0	1.5	0.6	0.3	5.0
20-50	7.0	3.5	2.5	1.0	0.5	8.0
50-100	10.0	4.5	4.0	1.5	0.7	12.0
100-1000	12.0	5.5	5.0	2.0	1.0	15.0
>1000	15.0	7.0	6.0	2.5	1.4	20.0

Notes:

1. Even harmonics are limited to 25% of the odd harmonic limits above.
2. *All power generation equipment is limited to these values of current distortion, regardless of actual I_{sc}/I_L .
3. Where I_{sc} = Maximum short circuit current at PCC.
4. And I_L = Maximum load current (fundamental frequency) at PCC.

Table 10.5-2 Harmonic voltage limits for power producers (Public Utilities or Non-Utility Generators)

HARMONIC VOLTAGE DISTORTION IN % AT PCC FOR SYSTEM NORMAL CONDITIONS*			
Maximum for:	≤ 69kV	69-138kV	>138kV
Individual Harmonic	3.0	1.5	1.0
Total Harmonic Distortion (THD)	5.0	2.5	1.5

*For start-up, inrush conditions, limits can be exceeded by 50%.

10.6 POWER SUPPLY TO VOLTAGE SENSITIVE EQUIPMENT COMPUTERS AND SENSITIVE EQUIPMENT

Customers who use computers, microprocessor controlled equipment, solid state devices, x-ray equipment, or other voltage sensitive electronic equipment should consider the installation of auxiliary devices designed to protect this equipment from power disturbances. These power disturbances may be in the form of voltage sags or surges, spikes, temporary loss of power, or any other deviation from normal. The Customer may have to safeguard this equipment by the application of line filters, solid state line-voltage regulators, transient suppressors, isolating transformers, uninterruptible power supply (UPS) systems or motor generators. Utility distribution systems normally operate between certain voltage limits as established by National Standards and state rules. The Company should be contacted for further guidance.

10.7 ISOLATION TRANSFORMER

Where lighting or other reduced-voltage equipment is permitted from existing 3-phase, 3-wire, delta non-standard services, isolation transformers are required. The secondaries of these isolation transformers shall be properly grounded. The minimum number of single-phase transformers that may be used to serve the reduced-voltage load on a 3-phase, 3-wire service is shown in the following table:

January 2019

Table 10.7-1 – Minimum Number of Single-phase Transformers to Serve Reduced-voltage Load on a 3-phase, 3-wire Service

Reduced-Voltage Load in Kilowatts or % of Total Demand on Service (whichever is larger)	Number of Transformers
Less than 5	1
5 to 10 inclusive	2
Over 10	3

The Company should be consulted prior to buying isolation transformers for this type of installation. Since auto-transformers do not provide isolation between primary and secondary windings, they shall not be used on 3-phase, 3-wire, ungrounded-delta service except to supply reduced voltage for motor starting. Auto-transformers used to supply other branch circuits shall be supplied only by a grounded system as outlined in the National Electrical Code or of any other applicable code.

10.8 VOLTAGE TOLERANCE BOUNDARY

Liberty Utilities follows the guidelines set forth in ANSI C84.1-2016 American National Standard for Electric Power System and Equipment – Voltage Ratings (60Hz).

Basically, the Range A service voltage range is plus or minus 5% of nominal. The Range B utilization voltage range is plus 6% to minus 13% of nominal.

If a customer's service voltage falls outside of Range A the company will investigate in a timely manner to determine if the issue is with Company service equipment or customer service equipment.

Nominal Standard	Service -5%, +%5	Utilization -13%, +6%	Nameplate Motor	NEMA -10%, +10%
120	114 - 126	104.4 - 127.2	115	103.5 - 126.5
208	197.6 - 218.4	181 - 220.5	200	180 - 220
240	228 - 252	208.9 - 254.4	230	207 - 253
277	263.2 - 290.9	241 - 293.6		
480	456 - 504	417.6 - 508.8	460	414 - 506
	bandwidth 10%	bandwidth 19%		bandwidth 20%

11.0 CUSTOMER-OWNED ELECTRIC SOURCES – INCLUDING STANDBY GENERATORS

11.1 GENERAL

Installations of Customer-owned generating equipment (or other electric sources) require adherence to fundamental rules for the safeguard of all personnel and the Company's equipment. Any generating equipment that is or can be connected to any circuit which is, or can be supplied from the Company's distribution system shall meet the requirements of this section. This is to prevent any unanticipated backfeed of electricity into the Company's system as required by the Company's applicable tariffs.

With the exception of emergency or standby generators, permitted by the Company for sole use during utility outages, all generating sources shall be metered at the generator(s) output.

Any non-residential Customer generation on its premise requires submittal of documentation to the Company in accordance with the Company's applicable tariff prior to installation. Consult the Company for the prescribed forms.

11.2 EMERGENCY AND STANDBY ELECTRIC SOURCES

11.2.1 Compliance Criteria

The Customer shall notify the Company prior to installing non-parallel, standby generating equipment and obtain approval for the method of connection. Where the Customer installs a standby generator for the purpose of supplying all or a part of the load in the event of an interruption in the supply of Company service, the Customer's wiring shall be arranged so that no electrical connection can occur between the Company's service and the Customer's other source of supply. This will require the installation of a double-throw, "break-before-make" type switch. This transfer scheme must meet these requirements established by the Company; see illustrations below. Unless required in Section 11.2.3, residential standby generator installations will not need prior Company approval since the Customer's electrical inspection approval certificate will ensure compliance with these Company specifications and the NEC.

January 2019

Figure 11.2.1-1 Standby Generator Non-parallel Operation with Company Connection Supplying Customer's Entire Load

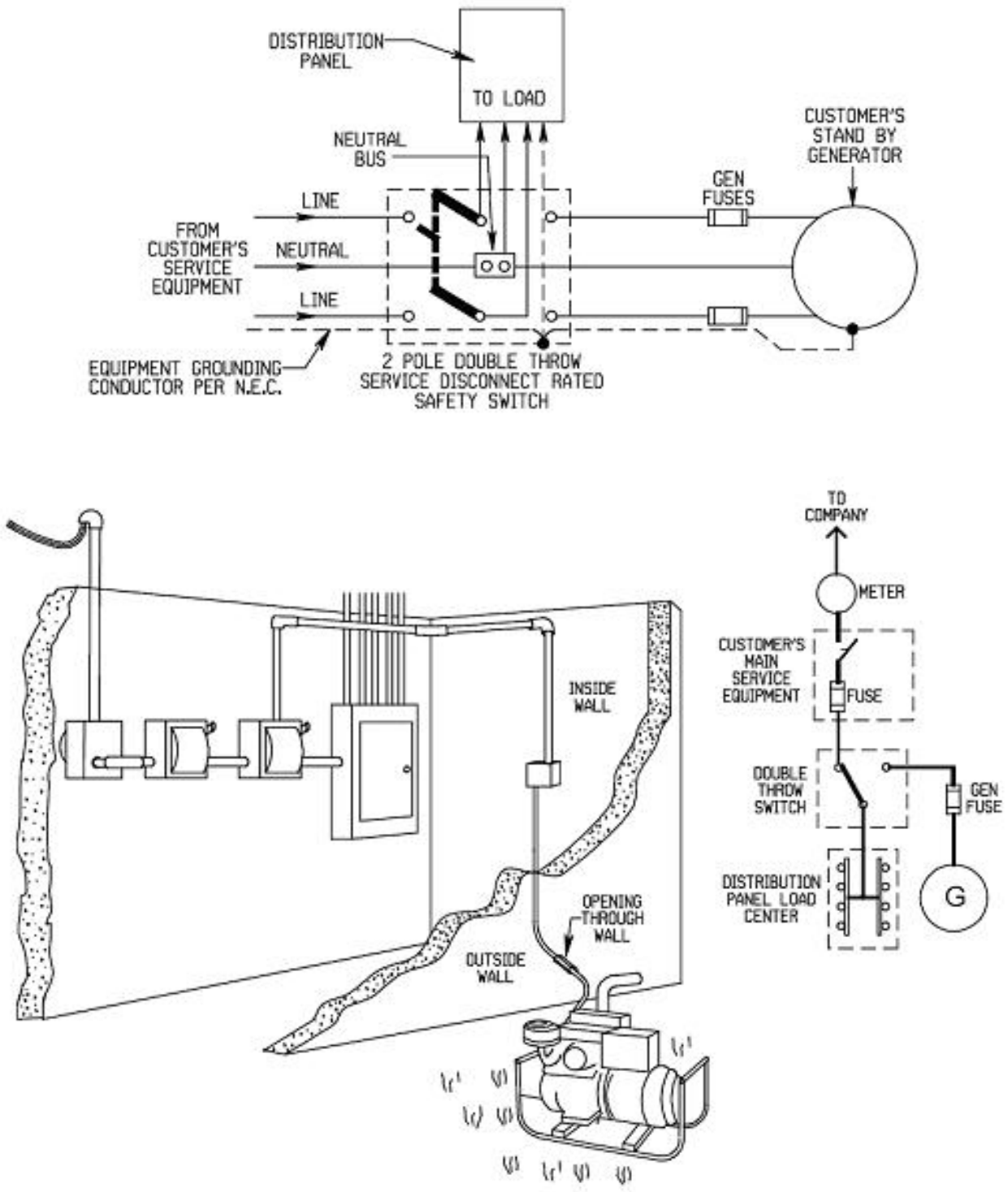

January 2019

Figure 11.2.1-2 Connection of Standby Generator Supplying One 120 volt Branch Circuit

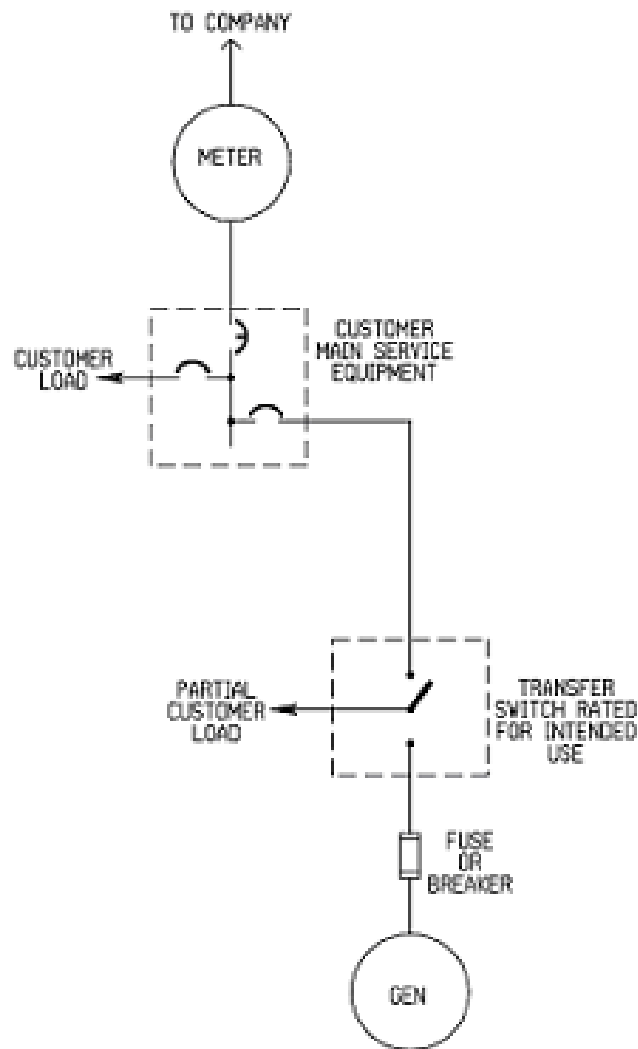
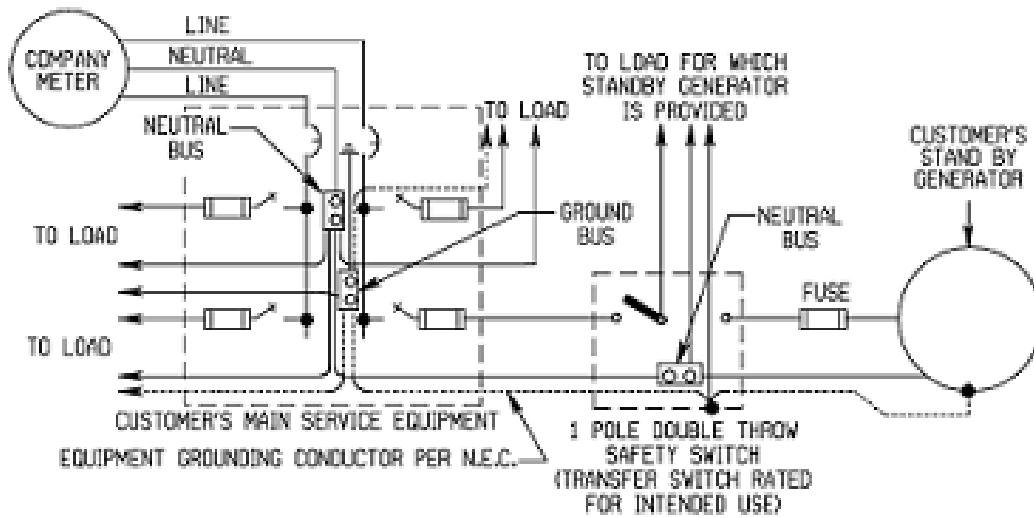

January 2019

Figure 11.2.1-3 Connection of Standby Generator Supplying One Building from Customer's Main Distribution Point

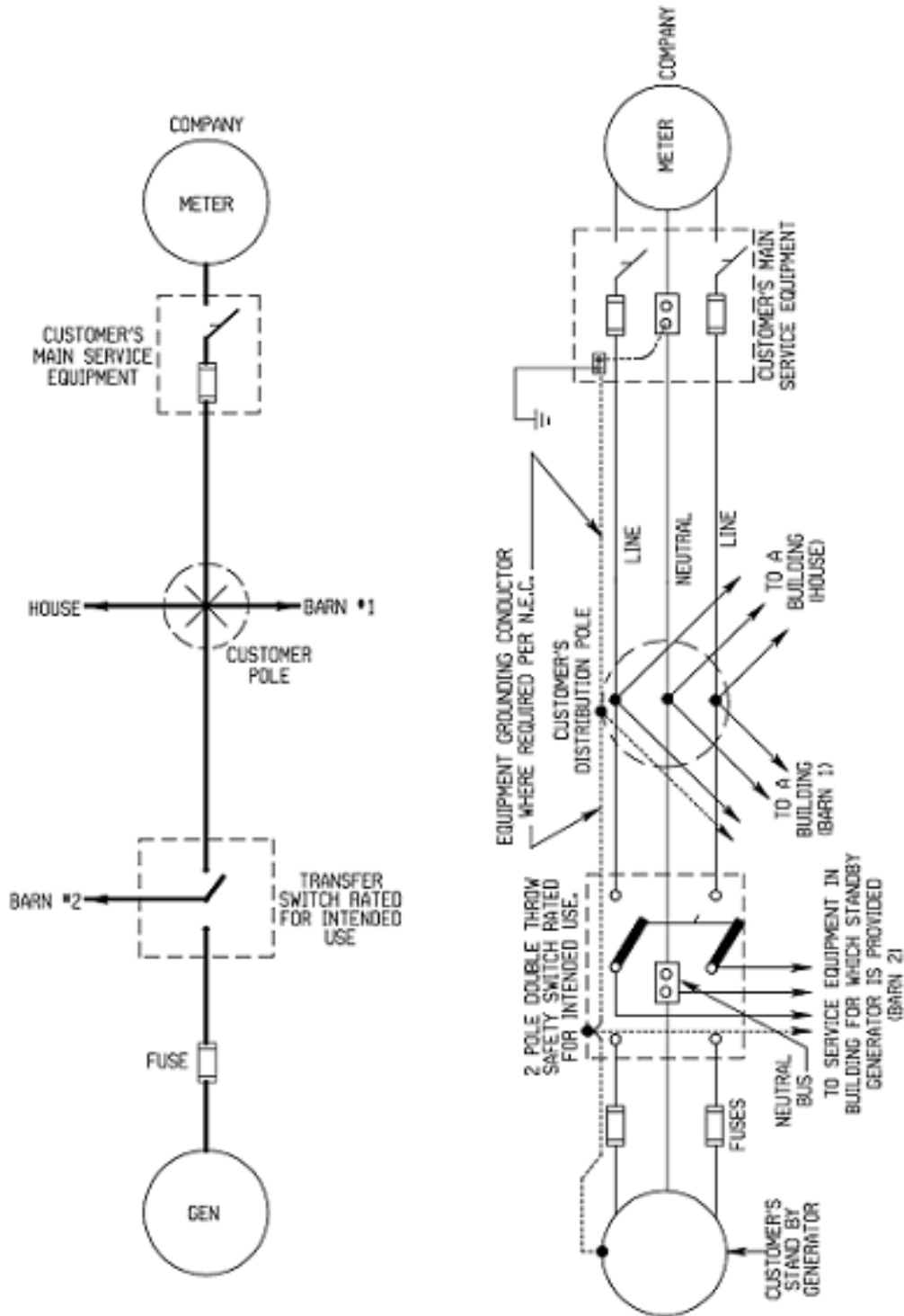

NOTE: CONNECTIONS SHOWN ARE FOR COMPANY'S SERVICE BEING SINGLE PHASE 3 WIRE 120/240 VOLTS.

A non-residential Customer utilizing generation shall meet the following requirements if it proposes the installation under the Company's definitions of emergency or standby power system:

- Accepted documentation on file with the Company.

January 2019

- Stated conditions when the Customer's emergency or standby generator may serve load on its premise for periods of time required by regulation or statute. Otherwise, test periods shall not exceed 10 hours per month.
- Maintain a written operating log indicating date, time, hours, and purpose of operation available to the Company upon request.
- Non-compliance will result in billing and installation of generator meter(s) in accordance with the Company's tariff.

11.2.2 Electric Source Type & Installation Method

11.2.2.1 AC or DC

The stand-by generator should be 60 Hertz alternating current. If a direct current generator is used, the installation must be arranged so that all motors, radios and other equipment that will not operate on direct current are disconnected from circuits before the circuits are energized from the stand-by generator.

11.2.2.2 Separately Derived Systems

When an AC generator is installed as a separately derived system, grounding of the neutral conductor shall be in accordance with the National Electrical Code. Separately derived systems require a switched neutral conductor in the transfer switch. Figures in this bulletin do not show this system configuration. The Customer is required to maintain safe step and touch voltages when installing a separately derived system in conjunction with the Company's electric service connection (this may require the services of a design professional).

11.2.2.3 Temporary Emergency Connections

To avoid serious risks to utility workers and the general public, Customers without permanently connected transfer systems may temporarily install emergency generators under the following conditions:

- Generator connection is made on the load side of the main disconnect device (i.e. circuit breaker, switch, or fuse block).
- The main disconnect device is tagged in the "open" position after ensuring disconnect is electrically open. The tag shall clearly state "do not operate".
- The Company's meter shall not be accessed.
- Notify the Company when electrical separation cannot be made by the Customer's equipment.

11.2.3 Transfer Systems

11.2.3.1 Service Equipment Rated Transfer

Transfer switches listed and labeled "suitable for use as service equipment" are permitted for use as main service equipment upon prior approval by the Company. See service equipment definition for necessary equipment arrangement. All other transfer switches shall be connected on the load side of the main service equipment.

11.2.3.2 Open-Transition Transfer

A double throw switch or contactor using a "break-before-make" sequence shall normally be provided to transfer all ungrounded conductors of an emergency lighting or power load to either the stand-by generator (or other electric source) or the normal supply.

January 2019

Figure 11.2.3.2-1 Double Throw Safety Transfer Switch
(Not Service Equipment Rated)

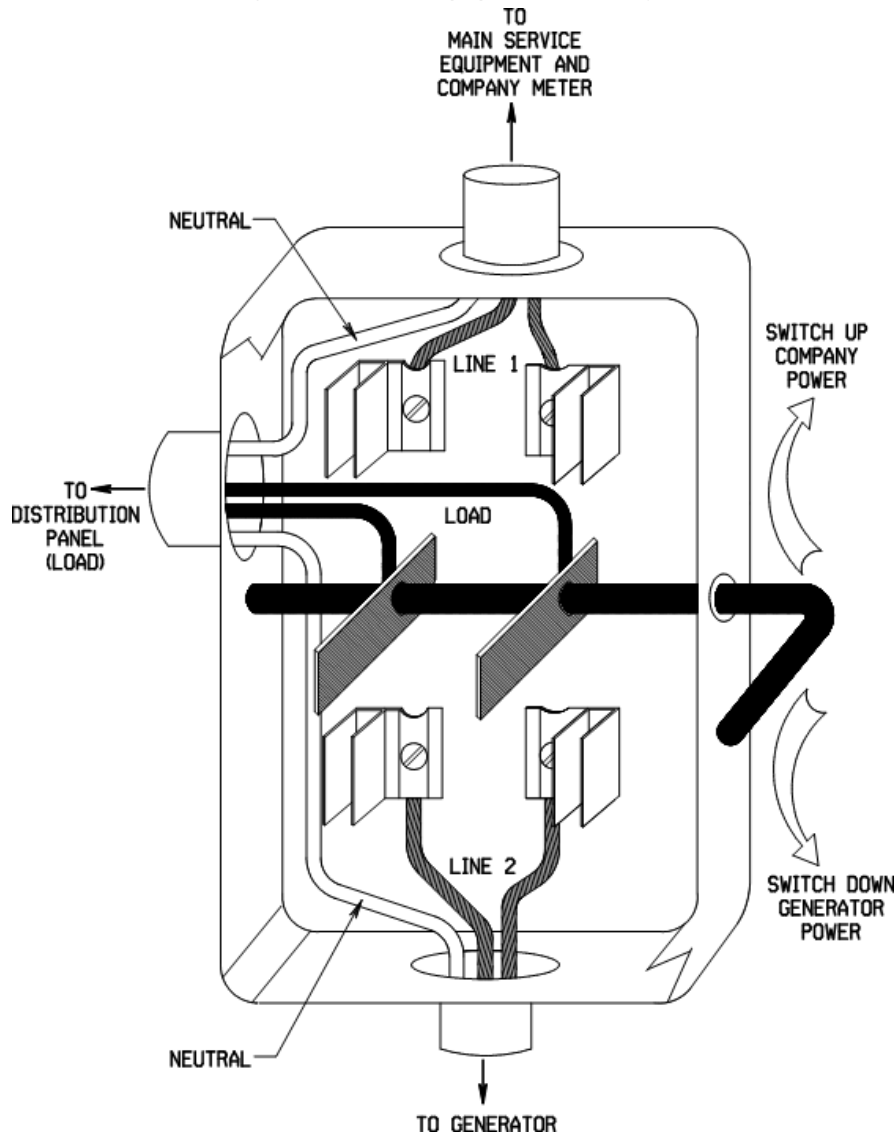

Where automatic throw-over switching is installed, the Customer shall provide an isolation switch in combination with each automatic transfer switch. The isolation switch shall provide a lockable means for manually isolating the emergency generator. The Company will tag the isolation switch in a locked open position during maintenance or repair of Company supply lines. Arrangements utilizing interlocking of single-throw devices are not acceptable.

11.2.3.3 Closed Transition & Auto Transfer

These requirements apply to closed transition schemes associated with standby or emergency generators where the generator will momentarily operate in parallel with the Company's system. This can be accomplished utilizing breakers or an Automatic Transfer Switch (ATS).

- The Customer shall submit for acceptance by the Company three copies of the single line, specifications, complete vendor prints, relay settings and a description of operation of the system.
- Requirements for Closed Transition Switching back to the Company's system:
 1. Closed transition switching shall occur within 15 cycles.
 2. Once the parallel is made, a transfer failure relay shall monitor the utility and generator breaker to ensure the transfer operation has been completed. If the transfer has not been completed within 30 cycles, the transfer failure relay shall trip the generator breaker. For ATS installations, the transfer failure relay shall monitor the switch contacts.
 3. The settings for paralleling the generator to the Company's system shall not exceed the values listed in Table 11.2.3.3-1. All devices that perform paralleling shall be utility grade, that is, they must meet the requirements of IEEE C37.90.1, 2, and 3.

Table 11.2.3.3-1 Relay settings to parallel standby or emergency generators with the Company system

Generator Size (kW)	Max. Frequency Difference (Δf, Hz)	Max. Voltage Difference (ΔV, %)	Max. Phase Angle Difference ($\Delta \Phi$, degrees)
0-500	0.3	10	20
>500 – 1,500	0.2	5	15
>1,500 – 10,000	0.1	3	10

4. The system shall be designed such that loss of the utility source will automatically open the utility breaker prior to closing the generator breaker (open transition).
 5. The system shall allow functional testing of the various operating and failure modes outlined in the description of operation.
 6. The Company reserves the right to witness functional testing of the transfer scheme, including failure modes. In these cases, it shall be the responsibility of the Customer to demonstrate proper operation and functional testing.
- Exercising Generator:
 1. If there is no load bank, and it is the intention of the customer to exercise the generator in parallel with the Company for an extended period of time (> 30 cycles), the generator shall meet the requirements of ESB 756.
 2. The Customer can exercise the generator with building load under requirements Items one through six above and the Company's filed Tariff.

11.2.4 Identification and Clearances

11.2.4.1 In accordance with the NEC, a sign shall be placed at the service-entrance equipment that indicates the type and location of on-site standby power sources.

January 2019

11.2.4.2 Customer's on-site generator and fuel storage are often located adjacent to Company pad-mounted transformers for ease in using the same trench to the electrical room. The Company requires protection between the transformer and the generator fuel storage unit, by either a twenty (20) foot (6 m) separation or a masonry wall. This wall should be erected parallel to and located three (3) feet (900 mm) from one side of the pad-mounted transformer foundation. The wall should be six (6) feet high and extend approximately three (3) feet (900 mm) beyond each end of the transformer foundation.

11.3 PARALLEL ELECTRIC POWER PRODUCTION

No Customer or Independent Power Producer (IPP) shall install or operate electric generation (or other electric sources) in parallel with the Company's system without prior notification to and approval by the Company.

Customers considering the installation of parallel electric power production equipment to supply all or a portion of their electrical energy requirements and who wish to arrange for, or continue to receive, service from the Company's system for their remaining electrical energy requirements and/or for stand-by service, must consult with the Company regarding the design, installation and operation of such equipment. (See Company's Electric System Bulletin No. 756 and its applicable appendix for additional details.) Precautions must be taken to maintain adequate safety and quality of service to other customers. Customers wishing to sell electric energy shall call the Company's Customer Service Center or those having managed accounts shall consult with their Account Manager for the Company's purchase policy.

11.3.1 Inverters

Direct current electric sources may be operated in parallel with the Company's system through a synchronous inverter where its installation will be designed such that a Company system interruption will result in the removal of the inverter from the Company's system. The Customer shall submit specifications for approval by the Company prior to procurement or installation of the inverter. (See Company's Electric System Bulletin No. 756 and its applicable appendix for additional details.)

12.0 UTILIZATION and SPECIAL EQUIPMENT

12.1 ELECTRIC FENCES

The Company urges extreme care in the selection of an electric fence system. A direct electrical connection to a fence or a connection through resistance, reactance, or lamp bulb, is not permitted without an approved controller. For guidance in safety methods, materials, and equipment to construct electric fences, those interested are referred to U.S. Department of Agriculture, Farmers Bulletin No. 1832 or to qualified experts.

12.2 SIGNS AND AUTOMATICALLY CONTROLLED LIGHTING

The Company shall be consulted in advance when signs or automatically controlled lighting are to be installed. Flashing signs shall be properly balanced throughout each portion of the flashing cycle.

12.3 LIGHTNING AND SURGE PROTECTION

When a Customer desires to install its own lightning or surge arrester it shall be connected on the load side of the main service disconnect by and at the expense of the Customer. For protection to be effective, such devices should be connected in conjunction with any applicable codes and approved by the AHJ. The Customer shall be responsible for providing, installing, operating, maintaining, and inspecting any such installations. The Company will not be responsible for damage to a Customer's equipment resulting from voltage surges that may occur on the Customer's wiring.

For services above 600 volts, lightning or surge arrester installations should be made in accordance with recommendations of the Company's Engineering Department and the applicable supplements to these specifications.

12.4 POWER FACTOR CORRECTION, CAPACITORS

Maintenance of high power factor is of the utmost importance to both Customer and Company in the operation of each of their distribution systems. Company rates are based, in general, on a minimum average power factor. The minimum average power factor value shall be that specified in the Company's applicable rate tariff that the billing is partly based on the reactive demand (RkVA) under which the Customer takes service. The Company should be consulted in advance regarding all installations likely to develop low power factors so that such conditions may be rectified by measures adapted to each proposed installation.

Customers are encouraged to maintain a power factor near 95 percent. The use of synchronous motors is desirable since these contribute to good power factor. Where possible, induction motors should be applied so as to operate at, or near, full rating.

12.4.1 Capacitor Installation

A Customer, installing capacitors to improve the power factor of its load, should obtain from the Company the characteristics of the supply system so that the capacitors can be properly applied. Consult the Company prior to procuring and installing power factor correction equipment for Company review and acceptance to assure that service to other customers will not be adversely affected by the manner in which such equipment is installed and operated.

12.4.2 Static VAR Compensators (SVC)

A Customer, installing static VAR compensators (SVC) to improve its power operating efficiency of its electric system, should obtain from the Company the characteristics of the supply system so that the SVC's can be properly applied. Consult the Company prior to procuring and installing SVC equipment for Company review and acceptance.

12.5 RADIO AND TELEVISION

12.5.1 Transmitting Station, Repeater, or High Frequency Equipment

Before a Customer installs and operates radio or television transmitters, repeater, or other high frequency equipment at a specific location, the Company shall be consulted for information on the type of electric service that will be supplied and the special precautions that must be observed so that the operation of this apparatus will not interfere with electric service to other Customers.

12.5.2 Antennas

Outdoor antennas for radio or television sets shall not be erected over, under or in close proximity to the Company's wires or any other wires carrying electric current, and shall not be attached to the Company's poles or Customer riser masts. To do so may result in serious accident or damage to equipment. Where practical, antenna conductors shall be installed so as not to cross under open electric conductors. Where proximity to electric conductors of less than 250 volts cannot be avoided, the clearance shall be at least two (2) feet (600 mm). In all cases, the National Electrical Safety Code conditions shall be met.

12.5.3 Eliminator or Trap

Installation of an eliminator or trap where necessary shall be suitable and shall be installed by the Customer in such manner as to prevent radio, telephone, television, and other interference feeding back into the supply circuit.

12.6 CARRIER CURRENT SYSTEMS

If a Customer uses building wiring for a carrier current system for remote control of power, communication, signaling, or other purposes, the Customer shall install suitable filter equipment or make other provisions approved by the Company to keep the Company's distribution facilities free from any high-frequency components or carrier currents produced by the Customer's equipment. Consult the Company prior to procuring and installing carrier current system equipment for Company review and acceptance. The Customer is also responsible for correction of any interference caused to other customers.

13.0 REVISION HISTORY

<u>Version</u>	<u>Date</u>	<u>Description of Revision</u>
1.0	07/01/12	Initial version of new document
2.0	07/31/14	Update Liberty Utilities' contact information
3.0	01/01/19	General update to reflect Tariff changes on UG Primary & Secondary ownership

Part C – “APPENDICES”

Appendix 1 - Overhead Attachment Methods

Overhead service attachment brackets shall be of Company approved materials.

Table App1-1 – Company-accepted Attachment Materials

<u>Item No.</u>	<u>Description</u>	<u>Vendor ID</u>	<u>Vendor Cat. No.</u>
B53A	Bracket, insulated service. Reinforced porcelain wire holder for attachment of multiplex services to 1-1/4” through 2-1/2” metal mast.	Joslyn Cooper	J0588 DW2C3
B53B	Bracket, insulated service. Reinforced porcelain wire holder for attachment of multiplex services to 3”to 4” metal mast.	Chance Cooper PPC Insul.	P1226 DW3C1 6913
B54	Bracket, insulated service. “House Knob.” Reinforced porcelain or nylon wire holder with 3” #22 hot dip galvanized wood screw. EEI TD 24 Style 5. (1)	Chance Joslyn Cooper PPC Insul.	3-11-45 JO893 DW2R4 1987
B17	Bolt, “J”. 3/8” x 11” galv. steel special for attaching service bracket to house. (2)	Joslyn Cooper	BT3917 DR6E1
I-10	Insulator Clevis. Insulated galv. assembled with dry process porcelain insul. for #2 AWG & #4 AWG triplex services. (1)	Joslyn Cooper	J1945 DC7F11
I-11	Clevis, insulated spool type sec. dead-end EEI-TD20-Item 2 clevis with ANSI C29.3 Class 53-3 insulator.	Joslyn Cooper PPC Insul.	J0342W/J97 DC3F66 4113
I-12	Clevis, secondary insulator clevis galv. steel for use with I-25 insulator (Not included) 3000# ult. For use on #1/0 AWG & 336 kcmil triplex services. 5/8” cotter bolt & s.s. cotter key. (2)	Chance Joslyn Cooper PPC Insul.	T207-0105 23491 DC13C4 4112
I-25	Insulator, sec. rack spec. ANSI C29.3-class 53-2, 0-600V.	Chance Joslyn Cooper PPC Insul. Victor Ins. Lapp	C909-0032 J151 WD684 5101 2012 8442-70
B7A2	2½” Expansion Shield Lag Screw, cast of zinc-base alloy. Long style for use with 3/8” lag screws on masonry construction. (1)	Diamond Rawl Star	001106 1155 1825-00200

Table App1-1 (cont'd)

<u>Item No.</u>	<u>Description</u>	<u>Vendor ID</u>	<u>Vendor Cat. No.</u>
B11A	3/8" x 3" Galv. Steel Lag Screw, with square head shoulder shank and gimlet point. (1)	Cooper Joslyn	DF3L3 J8773
B11B	3/8" x 4" Galv. Steel Lag Screw, with square head shoulder shank and gimlet point. (2)	Cooper	DF3L4
B13	Machine Bolt, 5/8" x 12" square head steel bolt (with nut). Galv. Steel with 6" min. thread length. (2)	Chance Hughes Cooper	8812 B612-4 DF3B12
W1	Flat Washer, 2-1/4" square x 3/16" Galv. Steel	Chance Joslyn Cooper Flagg (MIF) PPC Insul.	6813 J1075 DF2W4 P56A 6330

Notes: **(1)** For up to 600 lbs. service drop tension only.
(2) For up to 1100 lbs. service drop tension only.

Refer to the following illustrations for Company-accepted attachment methods.

Figure App1-1 – Illustrated Details of Overhead Service Attachment Methods: Details

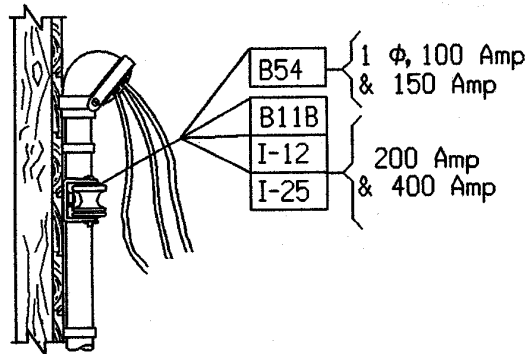

Detail 1

Insulated Service Attachment Bracket Assembly for Small Wood Frame Residence or Commercial Buildings

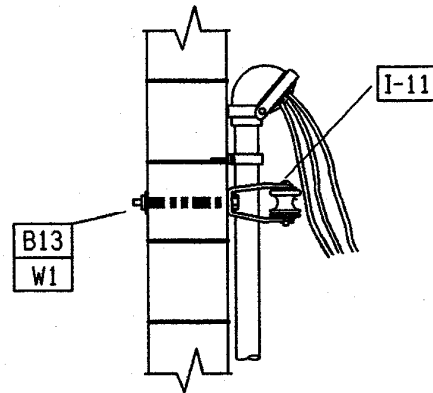

Detail 3

1 φ or 3 φ Attachment Bracket Assembly for Masonry Buildings or Steel Structural Support Member.

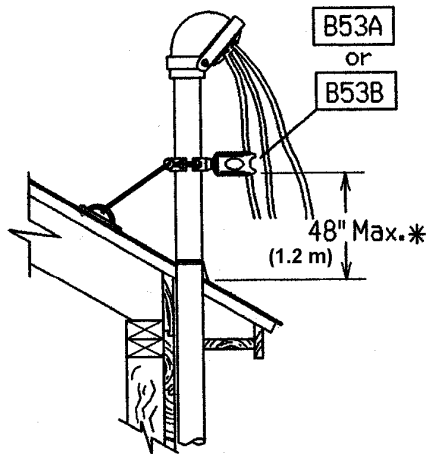

Detail 2

1 φ or 3 φ Attachment Bracket Assembly for Low Profile Buildings.

*** Note:**

Minimum Attachment Height shall be such that the Service drop's drip loop is not less than 18" (450 mm) above the roof.

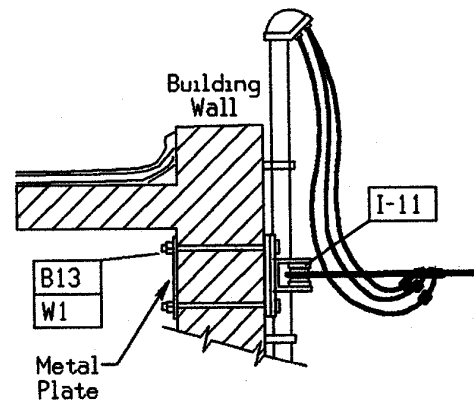

Detail 4

Attachment Bracket Assembly for 800 Amp Services

FIGURE APP1-2 – ILLUSTRATED DETAILS OF OVERHEAD SERVICE ATTACHMENT METHODS: ANCHORING

ANCHORING METHODS

- WOOD FRAME -

Preferred 200 Amp & 400 Amp

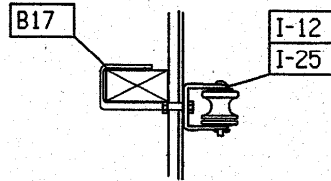

Alternate 200 Amp & 400 Amp

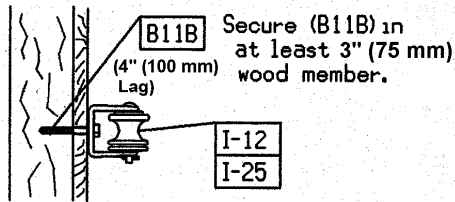

1 ϕ , 100 Amp
& 1 ϕ , 150 Amp

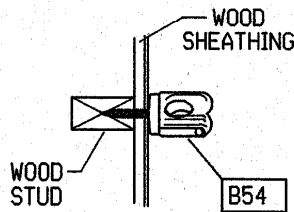

- MASONRY -

Preferred 200 Amp & 400 Amp

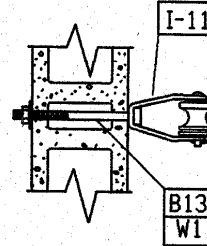

Alternate 200 Amp & 400 Amp For Existing Bldgs.

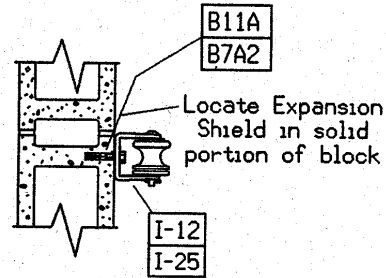

MATERIAL LIST

<u>ITEM</u>	<u>DESCRIPTION</u>	<u>ITEM</u>	<u>DESCRIPTION</u>
B53A	600V Insulated Service Bracket (1-1/4" (35) to 2-1/2" (63) pipe)	I-25	3", 600V Insulator
B53B	600V Insulated Service Bracket (3" (78) to 4" (103) pipe)	B7A2	2-1/2" (65 mm) Expansion Shield Lag Screw (Zinc Alloy)
B54	600V Insulated Service Bracket "House Knob" (3" (75 mm) Lag Screw)	B11A	3/8" (10 mm) X 3" (75 mm) Lag Screw
B17	3/8" (10 mm) X 11" (280 mm) "J" Bolt	B11B	3/8" (10 mm) X 4" (100 mm) Lag Screw
I-10	600 V Insulator Clevis	B13	5/8" (16 mm) Machine Bolt
I-11	600V Insulated Spool	W1	2-1/4" (57 mm) Square Flat Washer
I-12	3" (75 mm) Clevis		

Appendix 2 - Traffic Control Metered Service Requirements

(For D.O.T., Municipal, and individual customers as designated in the Company's applicable tariff.)

Notes for Figure App2-1

(The figure is typical in nature; however, variations may be permitted with prior consultation with the Company and approval granted in writing.)

NOTE #1 Raintight service head.

NOTE #2 Service bracket furnished and installed by Customer below weatherhead.

NOTE #3 Company service drop for overhead service. For underground service, Customer's cable-in-conduit (continuous) to Company's line.

NOTE #4 Service entrance cable or service entrance conductors in approved conduit. PVC Schedule 80 recommended, see Section 4. Bond metallic conduit in accordance with N.E.C. Article 250.

NOTE #5 Leave 24" (600 mm) of service entrance conductors for service drop connection by Company.

NOTE #6 Straps at not more than 30" (750 mm) intervals.

NOTE #7 Watertight fitting.

NOTE #8 Commercial meter socket trough furnished and installed by Customer in a true vertical position, see Section 7. Locate on structure away from traffic flow and such that the bottom of the meter socket trough is more than 8 feet (2.5 m) above grade. Or, the top of the meter socket trough must be below 6 feet (1.8 m) and there must be 8 feet (2.5 m) clear space without handholds or footholds starting at no higher than 6 feet (1.8 m) above grade. For service supplied from a network, a main disconnect is required and metering shall be cold-sequence.

NOTE #9 $\frac{1}{4}$ " (6 mm) dia. X $\frac{3}{4}$ " (19 mm) long bolts with nut and washer, all zinc coated steel. A total of four required, two for top, two for bottom.

NOTE #10 Slotted framing channel (Kindorf, Unistrut, Superstrut, or Company accepted equal), 12 gauge zinc coated steel, with holes, 1-1/2" (38 mm) h X $\frac{3}{4}$ " (19 mm) w X (length = width of associated meter socket). Two required, one for top, one for bottom.

NOTE #11 Meter support attached to Customer's structure with materials approved for the purpose.

NOTE #12 Outdoor service equipment, see Section 5. For transfer switch applications, refer to Section 12. Where in the public way and the Customer's structure is connected to the Company's overhead service drop, traffic controller equipment and service equipment shall be located such that the bottom of the equipment is more than 8 feet (2.5 m) above grade. Or, the top of the traffic control box must be below 6 feet (1.8 m) and there must be 8 feet (2.5 m) clear space without handholds or footholds starting at no higher than 6 feet (1.8 m) above grade.

NOTE #13 Install service entrance ground in accordance with N.E.C.

NOTE #14 10 ft. (3.0 m) minimum distance from service pole to Company's line, see Section 4 regarding clearances.

January 2019

Figure Appendix 2-1 – Typical Traffic Control Metered Service Installation

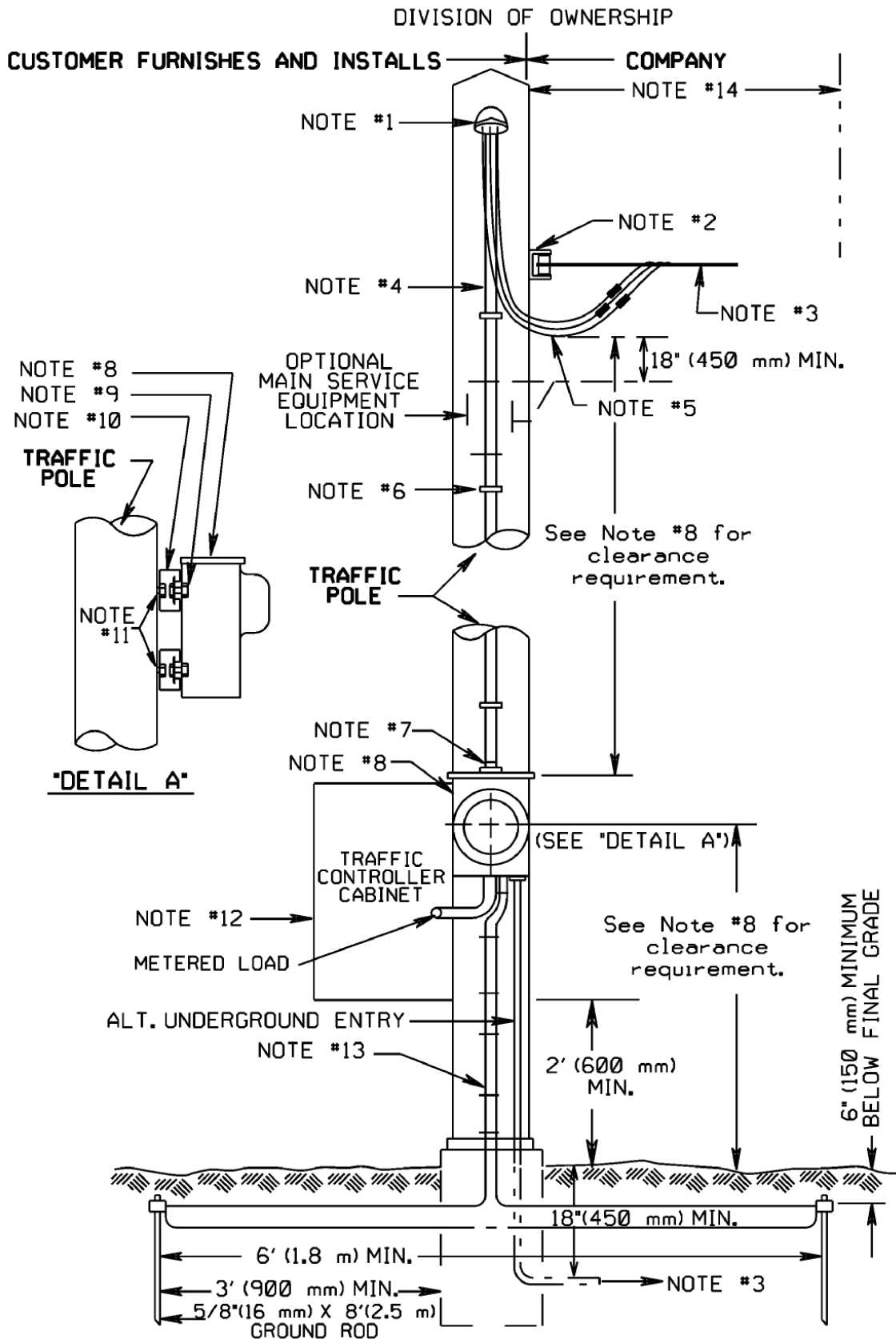

FOR THE LATEST AUTHORIZED VERSION PLEASE REFER TO THE COMPANY'S WEBSITE AT
<http://www.new-hampshire.libertyutilities.com/electricitypartners>

APPENDIX 3 – Distribution Wood Pole Mounted Meter Power Supply Installation

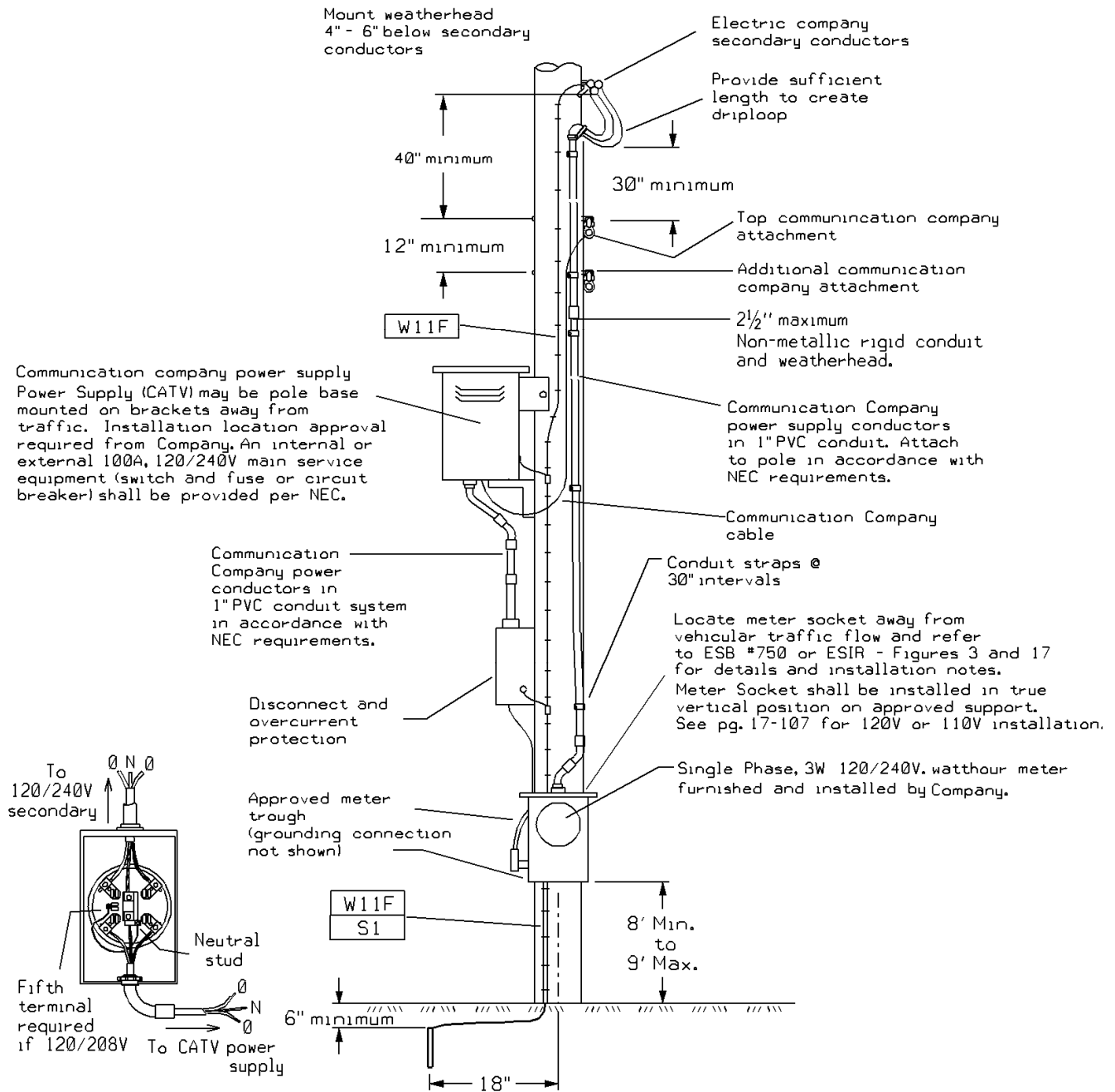

Socket Wiring Diagram

Top entry - bottom exit only

Notes:

1. All new or replacement power supplies are to be metered. Comm. Co. power supply installations should be avoided on poles with other equipment. Poles shall be accessible by bucket and the proposed installation shall be field reviewed and approved by the Company and any joint pole owners prior to work.
2. Comm. Co. shall furnish, install own and maintain all material and equipment shown above except as noted. Refer to ESB #750 or electric service information requirements (ESIR) Figure 923 depending on location.

APPENDIX 4 – ESB No. 759C Residential Underground Services

ESB No. 759C Residential Underground Services
 Electric underground residential service installation requirements
 (120/240V – 200A & 320A rated) October 2018

SAFETY FIRST

The safety of customers, contractors, company employees, and the general public is the number one priority of providing residential electric service connections.

The purpose of this document is to provide Liberty Utilities' electric underground residential service installations rules for basic requirements essential for maintaining satisfactory service or interconnection compatible with Liberty utilities' electric power system. These rules supplement, and may not exceed standards of safety regarding the Customer's electrical service installation set forth in the National Electrical Code (NEC) and the National Electrical Safety Code (NESC) and other applicable codes. These rules are not a substitute for the NEC, NESC, municipal codes, or any other authority having jurisdiction. Any service not installed in accordance with all applicable codes and installation rules in this document will not be connected to the Company's system. The Company accepts no liability for direct or indirect damages resulting from the Company's refusal to energize a service or the Company's termination of a service that does not meet these rules and all other applicable codes.

Builder/owner/developer/electrician must contact Liberty Utilities and request for a new electric underground residential service installation (120/240V – 200A or 320A rated) and obtain a work request number. This should be done as soon as practical in the process to provide for applicable planning, material order, and construction schedule.

Builder/owner/developer/electrician responsibilities:

- Obtaining any required municipal electrical permits and arranging electrical inspections.
- Providing, prior to the start of the *Company's* design, all applicable documents required for the *Company* to design an electric service.
- Providing, prior to the start of the *Company's* installation, a signed easement if required, drafted by the *Company*, for *Company* owned equipment on private property.
- **Service trench** – The trench shall be in as direct line as possible without reverse bends from the distribution facility to the customer service entrance. In order to minimize cable pulling forces, no more than two bends (not including riser at house or pole) exceeding a total combined change of 45 degrees shall be permitted.
 - Trench shall be of such depth to accommodate 24 inches minimum to 36 inches maximum cover.
 - In order to prevent the conduit from being pulled out of the meter box, conduit shall be installed on virgin or well tamped soil. Trench bottom shall be undisturbed or relatively smooth earth, well tamped, and free of any debris that may be detrimental to the conduit.
 - Conduit in the trench should have a 4-inch-per 100 feet downward pitch towards the distribution facility, if physically possible. (This provides drainage away from the service entrance, and prevents stagnant water in the duct.) The service riser to meter socket shall include an expansion coupling that allows for 8" fall.
 - The *Company* or Authority Having Jurisdiction (AHJ) will inspect and approve the conduit system and trenching prior to backfill.





ESB No. 759C Residential Underground Services
 Electric underground residential service installation requirements
 (120/240V – 200A & 320A rated) October 2018

- o Backfill shall not contain frozen material or stones larger than 2 inches in maximum dimension. Care should be exercised to avoid damage to conduit during backfilling. Backfill shall be compacted, and shall be completed before the Company schedules cable installation. Caution tape should be installed in trench above conduit 12" below finished grade.
- o When required, coordination with telephone, cable TV, or other utilities is the Customer's responsibility.
- **Conduit** – Standard conduit shall be 2 or 3-inch diameter, rigid PVC, heavy wall, sunlight resistant (6 percent – 7 percent titanium dioxide by weight), Schedule 40 as per ANSI/NEMA TC 2-2003.
 - o All 90 degree sweeps will be made using Schedule 40 PVC with a minimum radius of 24 inches for 3-inch diameter.
 - o Conduit should cross paved areas at approximately 90 degrees.
 - o A 1/4 inch nylon pull rope (minimum), including 10 feet of slack, shall be installed in the conduit. Secure the pull line to a plastic conduit plug for 3-inch diameter
- Providing and installing Company approved Self-contained Meter Socket at location **Pre-Approved By the Company**. Refer to Liberty Utilities ESB # 750 Specifications for Electrical Installations, latest version, Section 7.0 Metering, for self-contained Meter Socket requirements

Meter locations and clearances:

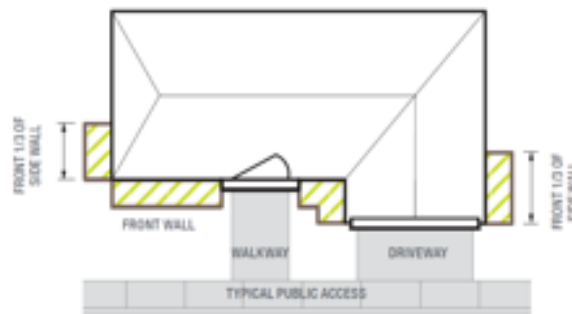

Meters shall not be located outside the shaded area in the diagram above.

Meters for newly installed services shall be located outdoors.

Meters must be located where they can be easily served from distribution system, identified, and accessed by Liberty Utilities.

Meters may be located on the front wall of the house relative to the driveway, or on the front third of either side wall relative to the driveway (see diagram above).

Electric meter to Gas Meter Clearances

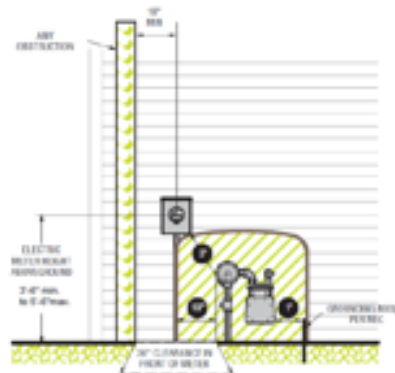



ESB No. 759C Residential Underground Services
 Electric underground residential service installation requirements
 (120/240V – 200A & 320A rated) October 2018

Electric meter base wiring and service conduit placement:

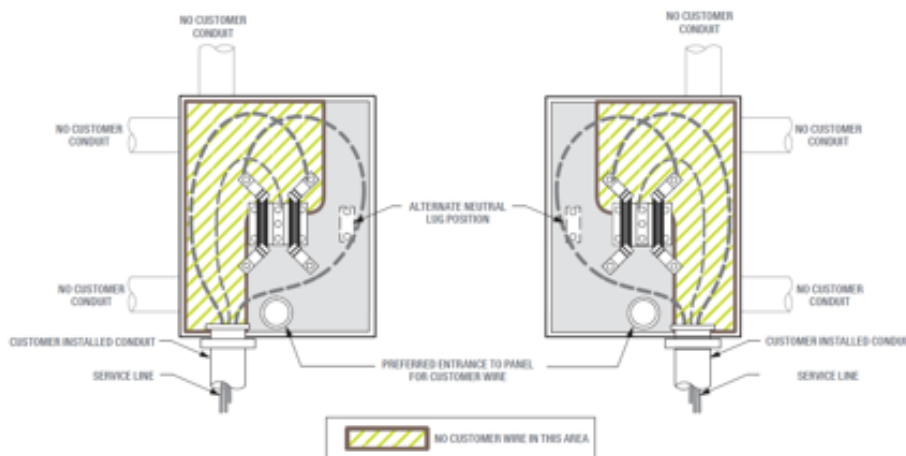

SERVICE PANEL SIZE	MIN LUG SIZE	BOTTOM KNOCKOUT	SERVICE WIRE SIZE	CONDUIT SERVICE RISER (@ METER)	CONDUIT DIAMETER. & TYPE	MIN. BEND RADIUS
100 AMP	1/0 AWG	2 INCH	1/0 AWG	2 IN GREY SCH 40 PVC	2 IN GREY SCH 40 PVC	24 INCH
200 AMP	4/0 AWG	3 INCH	4/0 AWG	3 IN GREY SCH 40 PVC	3 IN GREY SCH 40 PVC	24 INCH
320 AMP	350 KCMIL	3 INCH	350 KCMIL	3 IN GREY SCH 40 PVC	3 IN GREY SCH 40 PVC	24 INCH

Company's Responsibilities:

- Developing a plan to provide underground electric service.
- Designating the service location and meter location.
- Designating the *Company* distribution facility to supply the underground service.
- Provide *Company* easement documents, if required, for signature for the *Company* owned cable and equipment on private property.
- Approving trench and conduit system installation.
- Install, own, and maintain secondary cable and meter.
- Attach 2 1/2" x 2 1/2" adhesive-backed signs: "WARNING, UNDERGROUND CABLE" and 3" X 5" ELECTRIC SERVICE IN CONDUIT refer to diagram.
- Install *Company* identification tags on secondary cable at distribution facility supplying underground service.
- Connect service when the *Company* has been notified by the Wire Inspector or authority having jurisdiction (AHJ) of an electrical inspection approval.

Service from Handhole/Padmount Transformer:

- Extend conduit to designated *Company* handhole/padmount transformer foundation and mate to previously installed 10-foot 3" conduit stub. If no conduit stub is installed contact *Company* to assist with installation into existing handhole/padmount transformer foundation.



ESB No. 759C Residential Underground Services
 Electric underground residential service installation requirements
 (120/240V – 200A & 320A rated) October 2018

Caution – Customer/contractor shall not enter any Company structure because it could be energized.

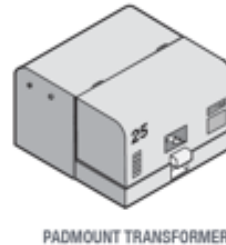
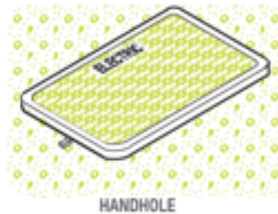

Service from Company Pole:

- Company will determine if underground residential service from an overhead distribution system is feasible and generally will be granted only from same side of street or roadway.
- Company will designate pole location, refer to Secondary Service Riser Pole detail below:

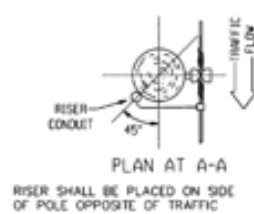

SPECIAL GROUNDING PROVISIONS FOR STEEL CONDUIT INSTALLATIONS ONLY

- INSTALL LISTED "U" BOLT WITHIN 6" (150mm) FROM TOP OF STEEL CONDUIT
- PROVIDE 30' (9.1m) OF GROUND WIRE PER NEC REQUIREMENTS. MIN #4 AWG COPPER FOR COMPANY CONNECTIONS
- PVC CONDUIT REQUIRES NO GROUNDING PROVISIONS

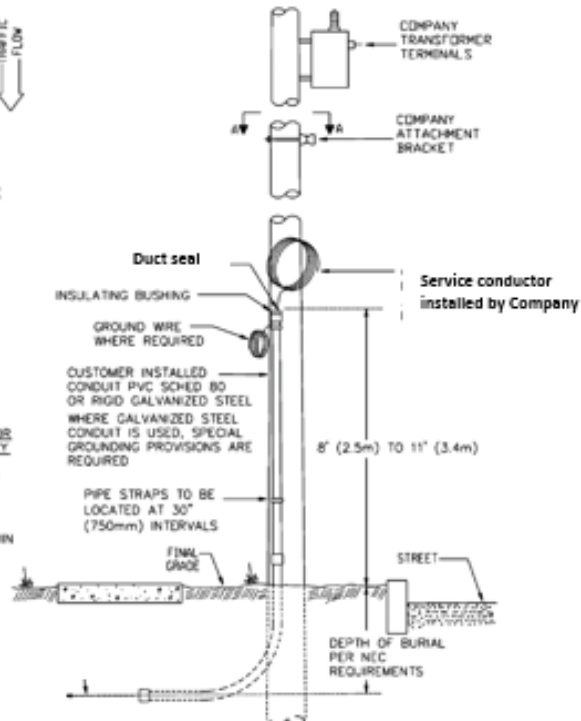

Limitations:

- In the event that a cable cannot be successfully pulled through the completed conduit system due to installation or construction, it will be the contractor's/customer's responsibility to locate and repair the involved conduit. The contractor will be responsible for all resulting expenses.

January 2019

SEIC LOG No. _____

CHANGE PROPOSAL FOR LIBERTY UTILITIES “SPECIFICATIONS FOR ELECTRICAL INSTALLATIONS”

INSTRUCTIONS — PLEASE READ CAREFULLY

Electronic media submittal of proposals is preferred. Type or print **legibly** in **black** ink. Use a separate copy for each proposal. Limit each proposal to a **SINGLE** section. All proposals must be received by Liberty Utilities' SEIC to be considered for the next revision of **ESB 750**. Proposals received that are not in the prescribed format will be returned to the submitter. If supplementary material (photographs, diagrams, reports, etc.) is included, please submit one (1) printed copy and the electronic file copies in Adobe Acrobat (pdf) for the Liberty Utilities Specifications for Electrical Installations Committee (SEIC).

SUBMITTED BY: (Include all appropriate information for contact purposes.) **DATE:**

Name	Street Address/City/State/Zip/Email Address (Or Internal Company Location)	Telephone No.

CHANGE PROPOSED FOR:

ESB Document No.	Section/Part/Paragraph/Article reference
750 (2019)	

PROPOSED CHANGE: (Include proposed new wording, or identification of wording to be deleted.)

SUBSTANTIATION: (Note: State the problem that will be resolved by your recommendation; give the specific reason for your proposal including copies of tests, research papers, fire or safety or operation experience, etc.)

I understand that I acquire no rights in any publication of Liberty Utilities in which this change proposal in this or another similar or analogous form is used.

SIGNATURE: _____

Mail suggestions to:
Liberty Utilities
15 Buttrick Road.
Londonderry NH, 03053
1-800-375-7413
Or, Email: www.libertyutilities.com

Electrical Inspections are a Vital Public Safety Function

Inspections Can Save Lives and Property: Inspections by qualified inspectors reduce the potential for fire and shock hazards due to incorrectly installed electrical products and systems covered by the National Electrical Code®, save lives, and reduce property damage that may result from unsafe electrical installations.

Inspections Mean Compliance with Laws: Most states and localities require electrical installations to comply with the National Electrical Code®, to protect public safety. Electrical inspections help confirm that electrical wiring and systems are installed “according to Code.”

Inspections Check for Safety Products: Most states and localities require electrical products to be “listed” by recognizing product safety certification organizations. Electrical inspections help confirm that properly certified products meeting U.S. safety standards are installed.

Inspections Confirm that Qualified Installers are on the Job: Electrical inspections protect against untrained or careless installers. Too often, unqualified installers perform unsafe electrical installations, and may also use products that don’t meet national safety requirements or local laws and codes.

No Public Funding: Government funding isn’t needed to pay for proper and thorough electrical inspections. The cost of inspections is usually covered by fees paid directly by builders and contractors. This vital public safety function doesn’t have to cost taxpayers or cash-strapped governments a dime.

Inspections Can Help Lower Insurance Premiums: Property insurance premiums are generally lower in areas with strong building codes enforced by professional inspectors. That’s because qualified electrical inspections help protect lives and property.

Signed by: The Inspection Initiative: An industry Coalition Supporting Qualified Electrical Inspections (First issued 1997)



Liberty Utilities provides water, electricity, and gas utility services to communities across the United States.

Serving over 750,000 customers in twelve states, Liberty Utilities is unique among its peers for its commitment to the community, conservation, and customer service. Liberty Utilities upholds the highest standards of service to meet the day-to-day needs of its customers and offers employee programs that recognize superior customer support and contribution to the community. Liberty Utilities has operations in Arizona, Arkansas, California, Georgia, Iowa, Illinois, Kansas, Massachusetts, Missouri, New Hampshire, Oklahoma, and Texas.

Liberty Utilities

15 Buttrick Rd
Londonderry, NH 03053
1-800-375-7413

www.libertyutilities.com