

Serial Number:

Purchase date:

Reseller:

Reseller's Tel:



COMPACT AIR TREATMENT UNIT

PENTACARE-V12 SERIES

USER GUIDE AND INSTALLATION MANUAL

(Second Edition)

(For use with Firmware Version 7)



**PLEASE READ THIS MANUAL CAREFULLY
AND KEEP IT FOR FUTURE REFERENCE**

Dear Customer,

Congratulations for purchasing this MINOTAIR product. Your MINOTAIR is a compact air treatment unit used to control the ventilation, temperature and humidity of your home. It does all this by filtering, dehumidifying, heating, cooling and renewing the indoor air – thus providing a healthy and comfortable environment all year round.

Our engineers have successfully integrated and optimized various techniques associated with ventilation and thermodynamics to build a high performance, energy-efficient device. As a result, the MINOTAIR offers superior recovery efficiency when compared to traditional Heat or Energy Recovery Ventilators. Not to mention that, unlike the MINOTAIR, none of these products can heat, cool or dehumidify by themselves. Only the MINOTAIR can claim to be truly multifunctional.

The MINOTAIR is easy to operate with its digital control, designed to focus on the factors directly affecting comfort and air quality. Whether it is about the ventilation rate, temperature or humidity level – the information is always available at a quick glance.

Furthermore, you can rest assured knowing that you will no longer be left behind when new features become available, thanks to the MINOTAIR's USB Port. This makes it possible to update the microcontroller when upgrades are released for download on our website. Gone are the days when you would find out that your brand-new device was quickly becoming obsolete as subsequent features were coming to market. Your MINOTAIR will keep evolving and benefiting you for many years. By the way, new features are offered free of charge!

Finally, please take the time to read this guide thoroughly. It was written for you and contains both practical and important information. It will help you get the most out of your device. Store it for future reference, preferably close to the device.

The whole team thanks you for choosing MINOTAIR.

A handwritten signature in black ink, appearing to read 'Karl Audet', with a long horizontal flourish extending to the right.

Karl Audet
President and Lead Engineer
MINOTAIR Ventilation Inc.

TABLE OF CONTENTS

Table of contents.....	3
Safety Definitions	6
Safety Instructions.....	6
Setting Expectations	7
Device Overview.....	8
Main Components.....	9
External Overview.....	10
Operating Modes.....	11
1. Air Exchanger Mode (Ventilation).....	11
2. Heat Pump Mode (Recirculation).....	12
3. Recirculation Mode without Compressor	13
4. Intermittent Mode	14
5. Smart Mode.....	15
Installation Procedures.....	16
Important Installation Requirements.....	16
Personal Safety.....	16
Regulations	16
Device Inspection.....	16
Choosing where to install the MINOTAIR	16
Choosing an Installation Method	17
Connection to a Forced Air Ventilation System – Simplified Method	17
Connection to a Forced Air Ventilation System – Extraction at the Source.....	18
Connection to an Independent System of Ventilation Ducts.....	19
Calculating Ventilation Airflow	20
Sizing Air Ducts.....	21
Guidelines for Air Ducts	23
Installing Flexible Ducts	25
Validating the Ducts Installation.....	25
Location of Indoor Grilles.....	26
Supply Grilles.....	26
Return Grilles	26
Location of Outside Hoods.....	26
Balancing the system.....	27
Balancing Registers	27

Balancing the MINOTAIR.....	27
Securing the MINOTAIR.....	28
Connecting the Condensate Drain.....	29
Connecting to Auxiliary Devices (Installation Options).....	30
Connecting to a 5 kW Electric Coil (Installation Option).....	31
Connecting to an Auxiliary Heat Pump (Installation Option).....	31
Connecting to a Bathroom Timer (Installation Option).....	32
Installing the Wall Mount Control (Installation Option).....	33
Selecting the Location.....	33
Adjusting Display Contrast.....	33
Cable Configuration.....	34
Wall-Mounting.....	35
Connecting the MINOTAIR.....	36
Digital Control Basics.....	37
Main Screen.....	37
Digital Control Buttons.....	38
Explanation of Symbols.....	39
Adjusting Display Contrast.....	40
Boot Sequence.....	40
Turning the Device On and Off.....	41
Adjusting Indoor Temperature.....	42
Adjusting Indoor Relative Humidity.....	43
Activate the Virtual Bathroom Timer.....	44
Main Menu.....	45
1. Ventilation Settings.....	45
"Ventilation" settings screen.....	45
"Ventilation" settings screen (cont'd).....	47
"Ventilation" settings screen (cont'd).....	47
"Ventilation" settings screen (cont'd).....	48
"Ventilation" settings screen (cont'd).....	48
"Ventilation" settings screen (cont'd).....	49
2. Adjusting Heating and Cooling Settings.....	50
"Temperature" settings screen.....	50
"Temperature" settings screen (cont'd).....	51
"Temperature" settings screen (cont'd).....	52

"Temperature" settings screen (cont'd).....	52
"Temperature" settings screen (cont'd).....	53
3. Adjusting Indoor Humidity Settings.....	54
"Humidity" settings screen.....	54
"Humidity" settings screen (cont'd).....	55
"Humidity" settings screen (cont'd).....	56
4. Adjusting Program Settings.....	57
"Program" settings screen.....	57
"Program" settings screen (cont'd).....	58
5. Adjusting Filter Settings.....	59
"Filters" settings screen.....	59
6. Other Settings.....	60
"Other settings" screen.....	60
"Clock" screen 1.....	61
"Clock" screen 2.....	61
"Tenant Mode" screen.....	62
7. System Info.....	63
"System info – Odometer" screen.....	63
"System info – Software version" screen.....	63
Alarm Descriptions.....	64
Maintenance.....	68
Limited Warranty.....	69
Limitations and Exclusions.....	69
Damage Claims.....	69
Other warranty rights.....	69
NOTES:.....	70

SAFETY DEFINITIONS



WARNING: Indicates a dangerous situation that, if not prevented, could cause serious injury or death.



CAUTION: Indicates a situation that may cause damages to the device or lead to material damage or physical injury.

SAFETY INSTRUCTIONS

Please read these instructions carefully. Failure to follow these instructions could result in damages to the device or other safety hazards. It is very important to understand how this air treatment unit operates and how to perform maintenance procedures safely.



WARNING: *Electrical hazard.*

This device operates at 120 VAC, which is enough to cause serious injury or death. Always cut power to the device before performing maintenance or repairs.



WARNING: *Heavy equipment.*

Improper handling or installation of this device may cause serious injury or death. At least two people are required to hang or take down the device. The device must be suspended using all four installation hooks included for this purpose.



WARNING: *Combustion products.*

Never proceed with the installation of an extraction grille in an enclosed space containing fuel-burning equipment that may be prone to back drafting of combustion products such as an oil furnace, hot water gas heater, stove, fireplace, gas dryer, etc. Combustion products can cause serious poisoning or death.

CAUTION: *Risk of head injury.*



Use caution when opening the main access panel while the device is hanging above ground. Always support the panel until completely opened.

CAUTION: *Risk of water damage.*



This device can condense tens of liters of water every day, depending on humidity levels in the air. The condensate drainpipe must be connected to a floor drain or a dedicated pump. Moreover, in certain situations, there could be condensation forming on the outside walls of the unit and the distribution ducts. In this case, isolating the distribution ducts and adding a drain pan under the device could be required for added protection.



CAUTION: *Cutting hazard.*

Although care has been taken to prevent sharp edges on various parts, always be careful when handling the device from its edges.



CAUTION: *Construction and renovations.*

Before undertaking major painting or sanding projects, shut off ventilation to avoid clogging the air ducts and filters.

SETTING EXPECTATIONS

The following list is meant to clarify expectations following commissioning of the MINOTAIR in accordance with the instructions set forth in this manual. Keep in mind that the MINOTAIR should be installed and maintained in accordance with this manual to ensure optimal performance for many years.

- **Ideal humidity levels.** During winter, a 35% humidity level is ideal. It is, however, possible to adjust this setting depending on personal preference or until condensation appears on the windows. If condensation starts forming, lower your humidity setpoint. Please note that if temperature is lowered for the night, condensation is likely to appear on the windows in the morning. Morning condensation is normal, as long as it goes away once temperature is brought back up to the daytime setpoint. In summer, a 45% humidity level is very comfortable. At all time, the indoor humidity setpoint may be hard to reach and maintain if your house is not airtight.
- **Humidity setpoint.** It can take up to a week from the device's initial start-up to reach the humidity setpoint. This is normal and depends on various factors such as climate, occupant habits, furniture, house size, insulation and airtightness. Regarding the airtightness of the house, if the humidity setpoint cannot be reached, it is likely that the supply of air naturally entering the home through cracks and openings exceeds the MINOTAIR handling capacity. In this case, a point of equilibrium will form which will tend to be more humid in summer and drier in winter.
- **Ventilation rate.** Too much ventilation will bring in an excessive amount of dry air in winter and humid air in summer. This could make it difficult to maintain humidity levels at the desired setpoint. On the other hand, insufficient ventilation will fail to renew the air in the house adequately and could lead to excess humidity. Make sure to follow the guidelines of this manual to plan and set the proper ventilation rate for your situation.
- **Auxiliary heating and cooling systems.** While the MINOTAIR is able to heat and cool a house for parts of the year, it is unlikely to do so completely without the help of an auxiliary system, especially during the cold winter months. Furthermore, several factors can influence your heating and cooling needs. These factors include climate, house size, insulation, airtightness, window quality and area, windows' orientation in relation to the sun, and, of course, occupant habits.
- **Device maintenance.** The MINOTAIR is a sophisticated and safe air treatment system. Its proper operation can only be ensured if the device is adequately maintained. Filters must be changed regularly – every 3 months – and replacement filters must be designed specifically for the MINOTAIR. Furthermore, the condensate drainpipe and the outside air intake/outlet hoods must be inspected at least every month. Clean them as necessary.

You are now ready to enjoy your MINOTAIR!

DEVICE OVERVIEW

The MINOTAIR is a multifunction device:

- Advanced control system.
 - Review the elements that affect comfort and air quality such as ventilation, temperature and humidity easily and at a quick glance!
 - Integrates the control of auxiliary units, including heating, cooling, and humidification for harmonized operations and maximum efficiency.
- High performance air exchanger.
 - Filters air while removing pollutants from the house, and oxygenates indoor air with fresh air from outside.
 - Dehumidifies and cools air in summer, and dehumidifies and recovers heat in winter.
- Self-contained heat pump.
 - Requires no installation of outside equipment other than the fresh air intake and stale air exhaust hoods.
 - Dehumidifies and cools air in summer; heats air in winter.
- Air Purifier with HEPA filtration.
 - Standard antimicrobial filters remove air dust, which could otherwise damage the device. These filters are MERV 8 (G4) rated and stop more than 90% of dust particles as small as 3.0 μm .
 - Standard MERV 15 (F9) High Efficiency filter removes up to 95% of particles as small as 0.3 μm .
- Powerful HumiWatch365[®] System.
 - Removes up to 56 liters/day (118 pints/day) of moisture from the indoor air depending on the level of humidity contained in the air, and without overheating air unlike conventional dehumidifiers.
 - Recovers the heat and moisture of showers to humidify indoor air when it is too dry, as required. Can also be connected to and control an auxiliary humidifier.



Figure 1 – MINOTAIR – Acts on temperature, humidity level and air renewal.

MAIN COMPONENTS

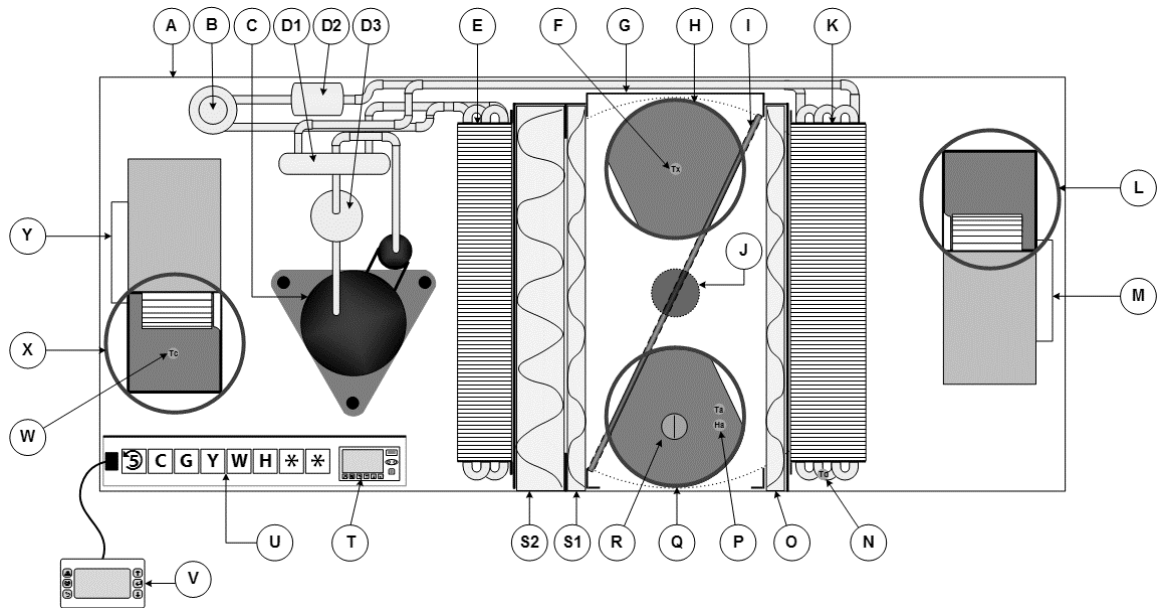

Figure 2 – MINOTAIR assembly and components.

- | | |
|---|---|
| <ul style="list-style-type: none"> A Insulated finished aluminum housing with resistant powder paint. B Bidirectional expansion valve. C High efficiency compressor D 1) Reversible valve.
2) Filter-dryer.
3) Muffler. E Energy recovery coil – Distribution side. F Sensor – Outdoor temperature. G Motorized damper housing. H Fresh air intake. I Motorized damper. J Motorized damper actuator. K Energy recovery coil – Extraction side. L Stale air outlet. M Constant airflow exhaust fan. | <ul style="list-style-type: none"> N Sensor – Defrost temperature O MERV 8 (G4) prefilter – Exhaust side. P Sensor – Indoor humidity and temperature Q Stale air intake. R Condensate pan cap. S 1) MERV 8 (G4) prefilter – Supply side.
2) High efficiency MERV 15 (F9) filter. T Microcontroller with integrated control. U Terminal board for auxiliary units such as a furnace, air conditioning and humidifier. V Wall mount digital control. W Sensor – Conditioned temperature. X Fresh air outlet. Y Constant airflow supply fan. |
|---|---|

EXTERNAL OVERVIEW

The MINOTAIR's housing is 100 % aluminum, which makes it lighter and easier to handle. Furthermore, aluminum is a long-term guarantee against corrosion which, otherwise, would end up weakening the housing structure since it is always in contact with humidity and condensates.

The air outlets are located on top of the device for easy installation. This eliminates the need to add elbows to redirect the airflow upward to reach the main ducts, which are often installed in the ceiling joists.

The four installation hooks designed to suspend the device are each secured with a bolt, which allows the hooks to be positioned at an angle. This in turn enables more flexibility when aligning the hooks with their anchor points.

The installation hooks and their polypropylene straps are designed so as to attenuate the propagation of vibrations from the device to the structure of the house.

The transportation feet are designed to protect the condensate drains from collapsing when the device rests on the floor. Furthermore, these feet create a space under the device, which makes lifting it much easier for installers.

Access to components requiring maintenance – filters for example – is possible from the front of the device by opening the main access panel.

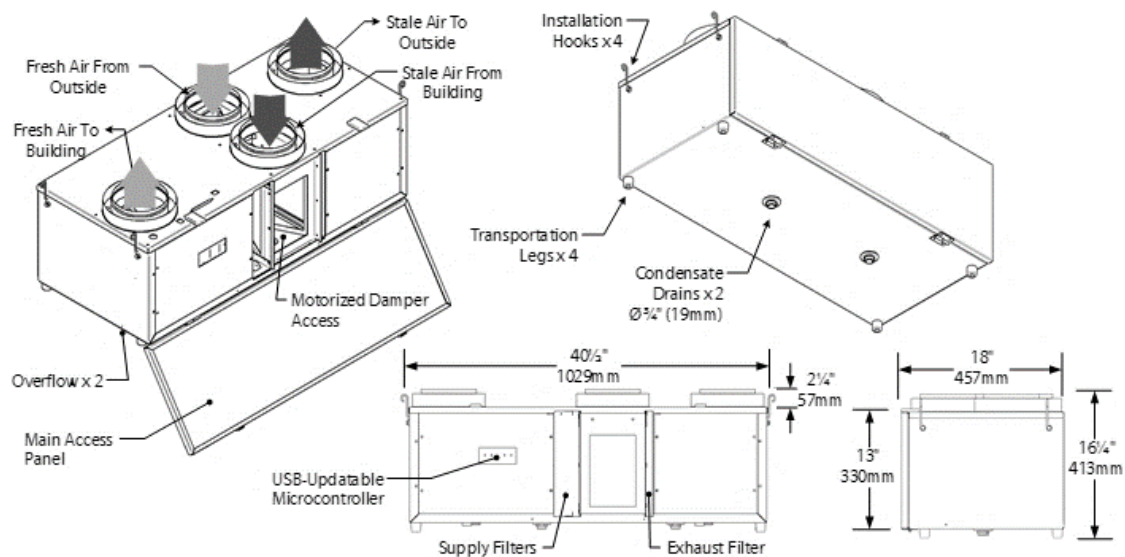

Figure 3 – External overview of the device.

OPERATING MODES

The MINOTAIR is the only system of its kind to combine a motorized damper with two constant airflow fans. The motorized damper can switch between two positions, which allow the MINOTAIR to function as either an air exchanger (ventilation) or a heat pump (recirculation). As a result, this allows for the development of various operating modes to optimize energy efficiency and occupant comfort.

1. AIR EXCHANGER MODE (VENTILATION)

- This mode controls two flows, one being fresh air and the other stale air. To operate in this mode, the motorized damper makes a full clockwise rotation until it is in contact with the angled walls. In this mode, the microcontroller sets the same airflow for each fan.
- Air Exchanger Mode features include:
 - Filters air while removing pollutants from the house, and oxygenates indoor air with fresh air from outside.
 - Dehumidifies and cools air in the summer.
 - Dehumidifies and recovers heat in the winter.
 - Can also humidify when connected to an inline humidifier.
- When to use:
 - When it is imperative to have a continuous supply of fresh air. Note that at certain times of the year, this mode could make humidity management difficult; air too dry in winter and too humid in summer. Moreover, this mode could tend to ventilate beyond the ASHRAE Standard 62.2 resulting in increased energy usage.

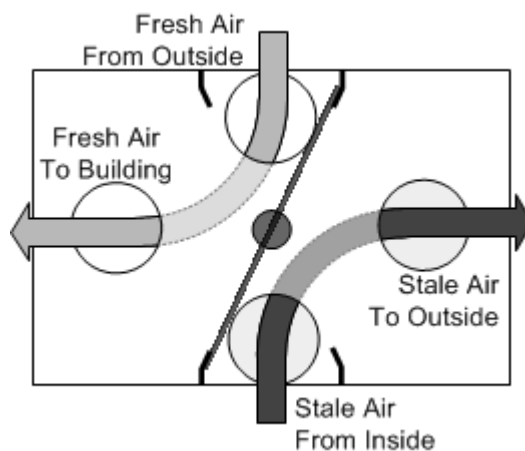

Figure 4 – Air Exchanger Mode (Ventilation).

2. HEAT PUMP MODE (RECIRCULATION)

- This mode controls two flows, one being indoor air recirculation and the other, outside air intake. To operate in this mode, the motorized damper makes a full counterclockwise rotation until it is in contact with the angled walls. In this mode, the airflows set by the microcontroller are not necessarily identical for the two fans, because the goal is to optimize the current operation (heating, cooling, and dehumidification). Thus, the left fan will usually have a lower airflow than the right fan, which should be close to the maximum possible airflow.
- Heat Pump Mode features include:
 - Dehumidifies and cools air in summer and heats air in winter.
 - Filters air while providing uniform humidity and temperature conditions.
 - Can also humidify when connected to an inline humidifier.
- When to use:
 - When comfort prevails over indoor air quality. Note that this mode does not allow any intake of fresh air, so it should not be used continuously.

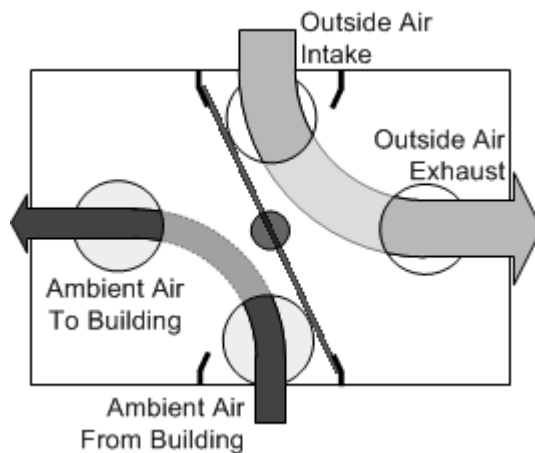

Figure 5 – Heat Pump Mode (Recirculation).

3. RECIRCULATION MODE WITHOUT COMPRESSOR

- This mode controls a single flow, which is indoor air recirculation. To operate in this mode, the motorized damper makes a full counterclockwise rotation until it is in contact with the angled walls. In this mode, the left fan operates at the airflow set by the microcontroller while the right fan is practically stopped except when measuring the outside air temperature.
- Recirculation Mode features include:
 - Filters indoor air while providing uniform humidity and temperature conditions.
 - Ultra-low energy consumption.
- When to use:
 - When it is not possible or desired to have a supply of fresh air and there is no reason to heat, cool or dehumidify. Note that this mode does not allow any intake of fresh air, so it should not be used continuously.

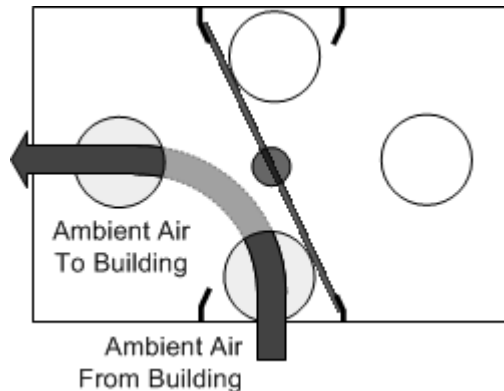

Figure 6 – Recirculation Mode without Compressor.

4. INTERMITTENT MODE

- This is a mixed mode that alternates between Air Exchanger and Recirculation modes. Four settings are possible:
 - **Intermittent-10.** Activates Air Exchanger Mode for 10 minutes before switching to Heat Pump Mode for 50 minutes, and so on.
 - **Intermittent-20.** Activates Air Exchanger Mode for 20 minutes before switching to Heat Pump Mode for 40 minutes, and so on.
 - **Intermittent-30.** Activates Air Exchanger Mode for 30 minutes before switching to Heat Pump Mode for 30 minutes, and so on.
 - **Intermittent-40.** Activates Air Exchanger Mode for 40 minutes before switching to Heat Pump Mode for 20 minutes, and so on.
- Intermittent Mode features include:
 - Lower energy consumption.
 - All the benefits of Air Exchanger and Heat Pump Modes, depending on the type of intermittency selected.
- When to use:
 - When it is necessary to have a guaranteed time-based supply of fresh air.
 - Ideal during prolonged absences to ensure a minimum supply of fresh air.
 - If air becomes too dry in winter, lower the intermittency as needed.
 - Could tend to over-ventilate if intermittency is set too high.

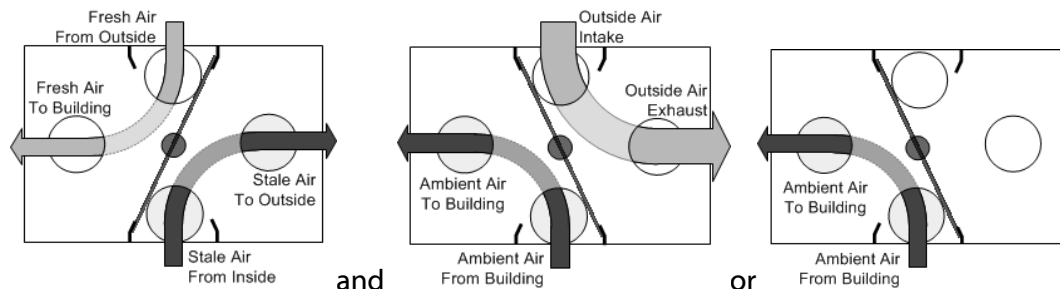

Figure 7 – Intermittent Mode 10, 20, 30 or 40 – with heat pump recirculation.

5. SMART MODE

- This is a mixed mode in which priority is given to humidity management and fresh air supply according to ASHRAE Standard 62.2. When the fresh air requirement is satisfied, the unit can switch to Heat Pump or Recirculation Mode as needed.
- Smart Mode features include:
 - Greatly optimizes humidity management.
 - Ensures strict compliance to ASHRAE Standard 62.2 over a two-hour time window.
 - Switches to heat pump mode upon calls for heat or cooling.
 - Switches to Free Cooling (no compressor) or to Turbo Cooling (free cooling with compressor) when outside temperature permits.
 - Goes into recirculation mode when the fresh air requirement is met and there is no need to heat, cool or dehumidify.
- When to use:
 - Always! Unless you have a specific reason to use a different mode, the Smart mode is the ideal and recommended option.
 - Combine the Smart mode with the operation of heating and cooling in *automatic* mode and you will get an integrated indoor air management system that is fully automated. In other words, once the unit is set to your preferences, you will forget it's there.

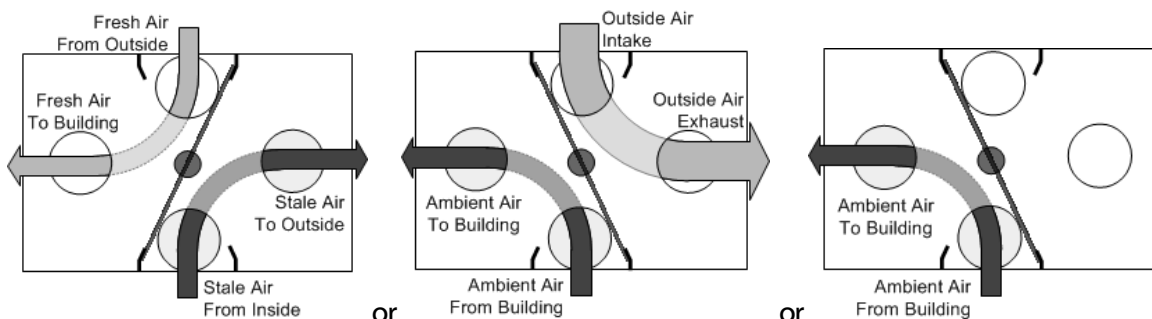

Figure 8 – Smart Mode.

INSTALLATION PROCEDURES

IMPORTANT INSTALLATION REQUIREMENTS

PERSONAL SAFETY

- Wear safety glasses when installing the MINOTAIR.
- Follow professional safety standards and all local regulations.

REGULATIONS

- **WARNING!** The MINOTAIR should be installed in accordance with the local building codes that are in effect. In absence of such requirements, it is advisable to check with local authorities having jurisdiction in your area.

DEVICE INSPECTION

- **WARNING!** Do not power on the device at this point.
- Inspect the exterior of the device to make sure it is not damaged.
- Make sure the panel, the hinges, the damper, the vents, the fan blades, the housing and the installation hooks are in good condition.
- Any damage sustained during transport must be reported within 24 hours of delivery.

CHOOSING WHERE TO INSTALL THE MINOTAIR

- Choose an accessible location that will allow and facilitate maintenance and repairs.
- Avoid lounging areas, offices and bedrooms. It is recommended to soundproof the selected location if it is too close to rooms where quietness is desired. In this case, use a solid core door and affix a rubber door sweep (weather strip) at its bottom to seal the space between the bottom of the door and floor. Do not use louvred or accordion doors as they have no soundproofing property.
- The device must be installed indoor, never outside, and the location must maintain an indoor temperature between 16°C and 27°C (60°F and 80°F).
- The device must be located near a 120 VAC electrical source, which must be dedicated to the device. No other device can use this same circuit.
- The location must be close to a floor drain. If that is impossible or if there is no floor drain in the house, you must install a condensate pump (not supplied) in order to eliminate condensation in a water return pipe. For example, a washing machine return pipe could be used. Condensate pumps can be found in most hardware stores.
- If the air ducts are not already installed, it is preferable to plan their course before deciding on the unit's final location.

CHOOSING AN INSTALLATION METHOD

- The MINOTAIR must be installed using one of the three following methods:
 - Connection to a forced air ventilation system – Simplified method.
 - Connection to a forced air ventilation system – Extraction at the source.
 - Connection to an independent system of ventilation ducts.

CONNECTION TO A FORCED AIR VENTILATION SYSTEM – SIMPLIFIED METHOD

- This is the easiest installation method, though not necessarily the preferred one. It will provide fresh air to all rooms supplied by the ventilation system. Stale air and humidity extraction is done through the return plenum which could make humidity management more difficult than if the extraction were done at the source.
- This method is only possible if the MINOTAIR can be installed in the same room where the forced-air system ventilator is located.
- It is required that the forced air ventilator runs continuously or ventilator operations is interlocked with the “G” terminal of the MINOTAIR.
- A minimum distance of 6 ft. (2 m) between the return and supply connections is required.

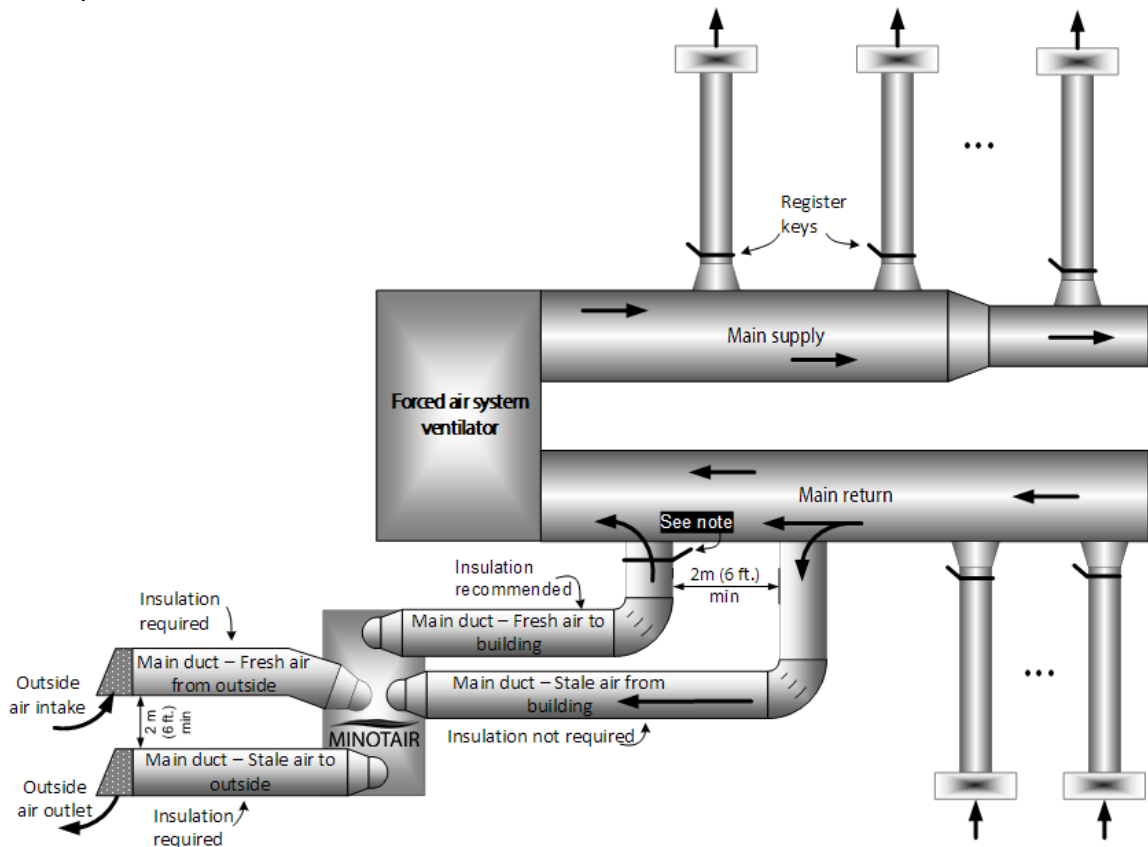

Figure 9 – Connection to a forced air ventilation system – Simplified method.
(The two MINOTAIR center ports are swapped for more clarity in the drawing)

NOTE: Refer to the section about “Balancing the MINOTAIR” to assess the need to add a register key at this location.

CONNECTION TO A FORCED AIR VENTILATION SYSTEM – EXTRACTION AT THE SOURCE

- This installation method is preferred over the “Simplified Method” described previously. If you must choose between the two, it is better to choose “Extraction at the Source” to fully benefit from the HumiWatch365© system.
- This method will provide fresh air to all rooms supplied by the ventilation system. However, stale air and moisture will be extracted directly at the source through dedicated ducts to ensure better humidity management.
- This option is only possible if the MINOTAIR can be installed in the same room where the forced-air system ventilator is located.
- It is required that the forced air ventilator runs continuously or ventilator operations is interlocked with the “G” terminal of the MINOTAIR.

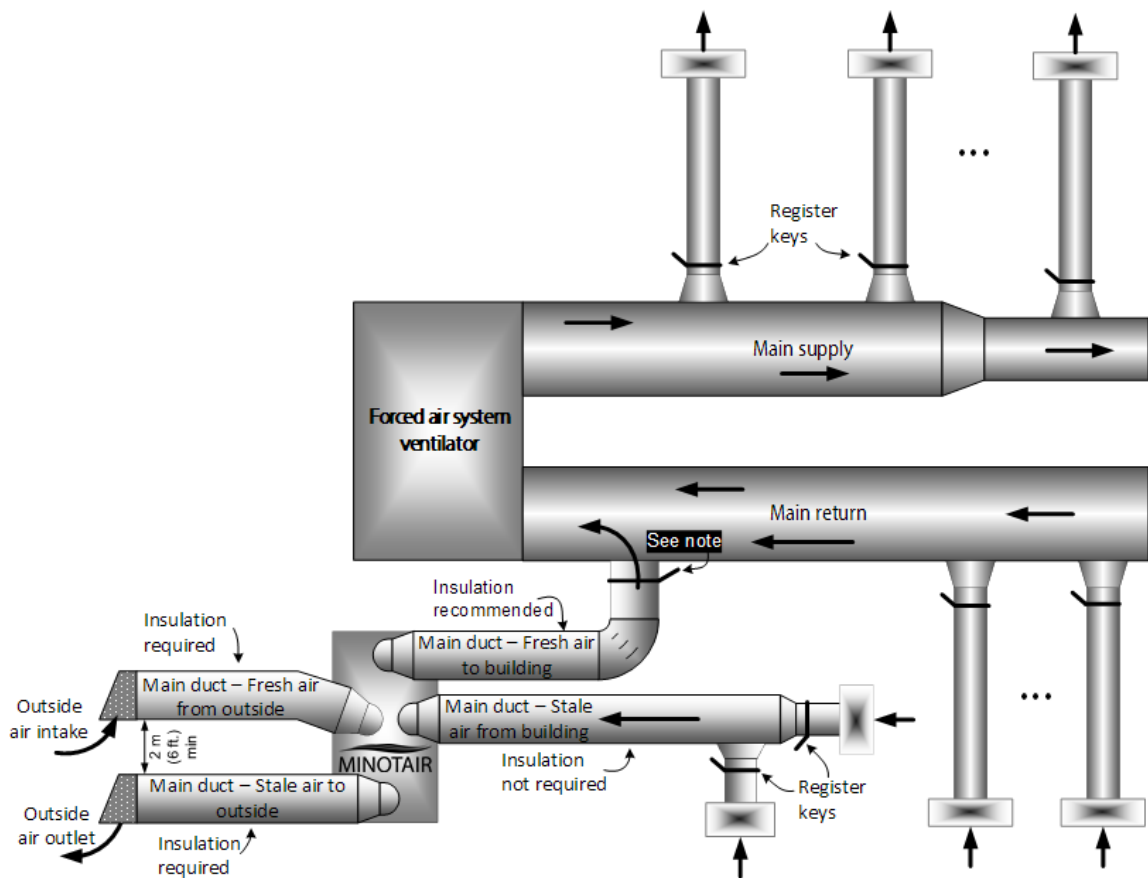

Figure 10 – Connection to a forced air ventilation system – Extraction at the source.
(The two MINOTAIR center ports are swapped for more clarity in the drawing)

NOTE: Refer to the section about “Balancing the MINOTAIR” to assess the need to add a register key at this location.

CONNECTION TO AN INDEPENDENT SYSTEM OF VENTILATION DUCTS

- This type of installation is required when the house is heated through electric baseboards or a radiant system. Since these systems do not include forced air ventilation ductwork, it is necessary to install a dedicated system of ventilation ducts.
- Like the previous method, stale air and moisture will be extracted directly at the source through dedicated ducts to ensure better humidity management. Therefore, one will be able to fully benefit from the HumiWatch365® system.
- For this type of installation, it is best to include a section of acoustic flexible duct measuring 1 m (3 ft) at the end of each supply branch. This will soundproof the air supply. The same can also be done for the return ducts.

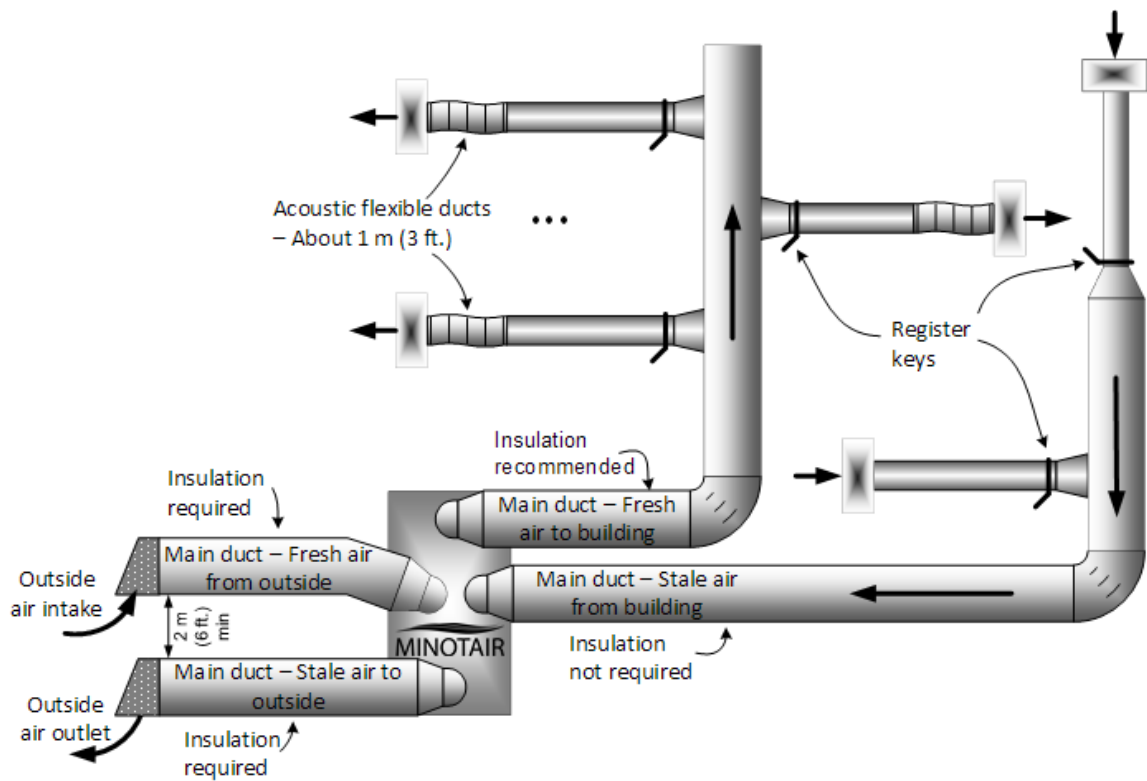

Figure 11 – Connection to an independent system of ventilation ducts.
(The two MINOTAIR center ports are swapped for more clarity in the drawing)

CALCULATING VENTILATION AIRFLOW

- The airflow rate of fresh air and stale air required throughout the house must be calculated by adding together the airflow required for each room, as indicated in the shaded columns below, unless calculated by a qualified professional. Airflows are denoted in cubic feet per minute (cfm) or liters per second (l/s).
- The smaller a room is in comparison to the other rooms, the closer the airflow rate must be to the "Min" value. Bigger rooms will require airflow rates closer to the "Max" value.

For each dwelling		Recommended airflow for each room				Air ducts diameter for each room			
		cfm		l/s		in		mm	
		Min	Max	Min	Max	Min	Max	Min	Max
SUPPLY	Rooms requiring a fresh air supply*								
	Each bedroom (one person)	10	20	5	10	5	5	125	125
	Each bedroom (two persons)	20	30	10	15	5	6	125	150
	Home office	10	20	5	10	5	5	125	125
	Main lounging room (living room)	10	20	5	10	5	6	125	150
	Each floor not already serviced by air supply	10	20	5	10	5	6	125	150
	Basement if not already serviced by air supply	10	20	5	10	5	6	125	150
	Optional rooms to be supplied with fresh air*								
	Dining room	10	20	5	10	5	6	125	150
	Family room	10	20	5	10	5	6	125	150
	Play room	10	20	5	10	5	6	125	150
	Kitchen (This will help the range hood work better).	10	20	5	10	5	6	125	150
	Any other furnished room	10	20	5	10	5	5	125	125
	EXTRACTION	Recommended rooms for stale air extraction*							
Bathroom or shower		50	80	25	40	5	6	125	150
Restroom		10	20	5	10	5	5	125	125
Kitchen (Not recommended. Use a range hood instead.) (Minimum distance between the return grille and any cooking surface must be 3 m (10 ft.)).		10	20	5	10	5	6	125	150
Laundry room		10	20	5	10	5	5	125	125
Basement		10	20	5	10	5	6	125	150

* Treat each room comprised in an open space as an individual room

	Required fresh air supply <i>Write result</i>		Main ducts minimum diameter			
	cfm	l/s	cfm	l/s	in	mm
Total fresh air supply ^{1,2}			≤ 90	≤ 40	6	150
1. Input this value into the microcontroller. 2. The total exhaust airflow must be identical	<i>Your answer</i>	<i>Your answer</i>	> 90	> 40	8	200

Table 1 – Airflow planning.

SIZING AIR DUCTS

- To minimize turbulence and ventilation noise, the ducts must be sized based on the numbers in the shaded columns below, unless they have been otherwise sized by a qualified professional. The conduit diameters are denoted in inches (in) or in millimeters (mm).
- The duct diameter must be proportional to the airflow established for the room. Thus, if the airflow has been established based on the "Min" column, then the duct diameter should also be sized according to the "Min" column. If the "Max" column or another value in-between was used then the duct must be sized according to the "Max" column, or the adequate value in-between "Min" and "Max". If there is no in-between value, use the "Max" value.
- If in doubt, use the "Max" value.

For each dwelling		Recommended airflow for each room				Air ducts diameter for each room			
		cfm		l/s		in		mm	
		Min	Max	Min	Max	Min	Max	Min	Max
SUPPLY	Rooms requiring a fresh air supply*								
	Each bedroom (one person)	10	20	5	10	5	5	125	125
	Each bedroom (two persons)	20	30	10	15	5	6	125	150
	Home office	10	20	5	10	5	5	125	125
	Main lounging room (living room)	10	20	5	10	5	6	125	150
	Each floor not already serviced by air supply	10	20	5	10	5	6	125	150
	Basement if not already serviced by air supply	10	20	5	10	5	6	125	150
	Optional rooms to be supplied with fresh air*								
	Dining room	10	20	5	10	5	6	125	150
	Family room	10	20	5	10	5	6	125	150
	Play room	10	20	5	10	5	6	125	150
	Kitchen (This will help the range hood work better).	10	20	5	10	5	6	125	150
Any other furnished room	10	20	5	10	5	5	125	125	
EXTRACTION	Recommended rooms for stale air extraction*								
	Bathroom or shower	50	80	25	40	5	6	125	150
	Restroom	10	20	5	10	5	5	125	125
	Kitchen (Not recommended. Use a range hood instead.) (Minimum distance between the return grille and any cooking surface must be 3 m (10 ft.)).	10	20	5	10	5	6	125	150
	Laundry room	10	20	5	10	5	5	125	125
	Basement	10	20	5	10	5	6	125	150

* Treat each room comprised in an open space as an individual room

	Required fresh air supply <i>Write result</i>		Main ducts minimum diameter			
	cfm	l/s	cfm	l/s	in	mm
Total fresh air supply^{1,2}			≤ 90	≤ 40	6	150
1. Input this value into the microcontroller. 2. The total exhaust airflow must be identical	<i>Your answer</i>	<i>Your answer</i>	> 90	> 40	8	200

Table 2 – Air ducts planning.

- The main ducts' diameter depends on the airflow that was calculated at the previous step. If the calculated airflow is 90 cfm (40 l/s) or less, it is possible to use main ducts of 6" (150 mm). The maximum airflow of the main ducts will then be required to be adjusted between 180 cfm and 215 cfm (85 l/s and 100 l/s) in the microcontroller's ventilation menu. Note, however, that this setting will decrease heating and cooling capacity in heat pump mode by up to approximately 25% depending on current temperatures and humidity level.
- If enough space is available, it is always preferable to choose main ducts of 8" (200 mm) to use the MINOTAIR to its full. The maximum airflow of the main ducts will then be required to be adjusted between 220 cfm and 250 cfm (105 l/s and 120 l/s) in the microcontroller's ventilation menu. If space does not allow the use of 8" (200 mm) ducts for all main ducts, you must favor the main distribution duct (fresh air to building) to minimize the ventilation noise at the supply grilles.
- **IMPORTANT!** In high speed or heat pump mode, airflow increases significantly. To minimize the noise of the air in motion, it is recommended to have a minimum number of supply and return ducts based on whether the main ducts are 6" (150 mm) or 8" (200 mm) in diameter:

- **Main ducts – 6" (150 mm) for an airflow ranging between 180 cfm and 215 cfm (85 l/s and 100 l/s):**

*Minimum recommendations for **supply** ducts:*

- Minimum 2 x 6" (150 mm) duct, or
- Minimum 1 x 6" (150 mm) duct and 2 x 5" (125 mm), or
- Minimum 4 x 5" (125 mm) ducts.

*Minimum recommendations for **return** ducts:*

- Minimum 1 x 6" (150 mm) duct and 1 x 5" (125 mm), or
- Minimum 3 x 5" (125 mm) ducts.

- **Main ducts – 8" (200 mm) for an airflow ranging between 220 cfm and 250 cfm (105 l/s and 120 l/s):**

*Minimum recommendations for **supply** ducts:*

- Minimum 3 x 6" (150 mm) ducts, or
- Minimum 2 x 6" (150 mm) duct and 2 x 5" (125 mm), or
- Minimum 1 x 6" (150 mm) duct and 3 x 5" (125 mm), or
- Minimum 5 x 5" (125 mm) ducts.

*Minimum recommendations for **return** ducts:*

- Minimum 2 x 6" (150 mm) ducts, or
- Minimum 1 x 6" (150 mm) duct and 2 x 5" (125 mm), or
- Minimum 4 x 5" (125 mm) ducts.

GUIDELINES FOR AIR DUCTS

- All ventilation ducts must be made of rigid materials, in galvanized sheet metal or an equivalent material, and be cleanable when needed. However, if rigid ducts are not a possibility, flexible materials can be used (see “Installing flexible ducts”).
- Air ducts must always be installed on the warm side of the building envelope, such as the interior walls, the floors or the ceilings. Avoid installing ducts in the attic or in unheated spaces, but where this cannot be avoided, use ducts with an R-Value of at least R-8 (RSI 1.4), **ideally R-20 (RSI 3.5)**. Attics can reach extremely high temperatures in summer and very cold temperatures in winter.
- All air ducts located on the cold side, namely the fresh air intake from outside and the stale air exhaust to outside, must have an R-value of at least R-4 (RSI 0.7), **ideally R-8 (RSI 1.4)** especially if your location is subject to harsh winters where it's not uncommon to reach -20°C (-4°F) and below.
- It is advisable to fully insulate the supply ductwork with an R-Value of R-4 (RSI 0.7) to minimize energy losses when distributing heated or cooled air. If this is not possible, it is nonetheless advisable that at least the first 6 feet (2 m) of the supply ductwork starting from the Minotair be insulated.

CAUTION! During cooling and dehumidification operations, condensation could form on the outside walls of the unit and the supply ducts, which could cause water damage. In this case, isolating the supply ducts and adding a drain pan under the Minotair could be required for added protection.

- It is not necessary to insulate return ducts unless there is a risk of condensation.
- All insulating sleeves must be equipped with an adequate vapor barrier film, preferably made of aluminum. All joints must be airtight and sealed with aluminum tape as required.
- All ducts that go through an air or vapor barrier must be sealed hermetically at the point of entry.
- All ventilation ducts must be airtight. To achieve this, all joints, cracks and holes on the ducts, as well as all fittings, must be sealed with mastic or aluminum tape.
- Straight tees and elbows (without bends) should be avoided. Choose wye fittings and curved elbows for better flow and soundproofing.

- **IMPORTANT!** To minimize the static pressure (air restriction) in the ventilation ductwork, departures on the four vents must be vertical and **WITHOUT** any bend radius exceeding 30°. The length of each vertical departure must measure a minimum of 6" (15 cm). It is recommended to use 6" to 8" increasers to allow for efficient airflow and ease-up the installation of insulation sleeves. Tuck the insulation between the 6" and 8" port walls, and tape the vapor barrier to the outside wall of the 8" port with aluminum tape.

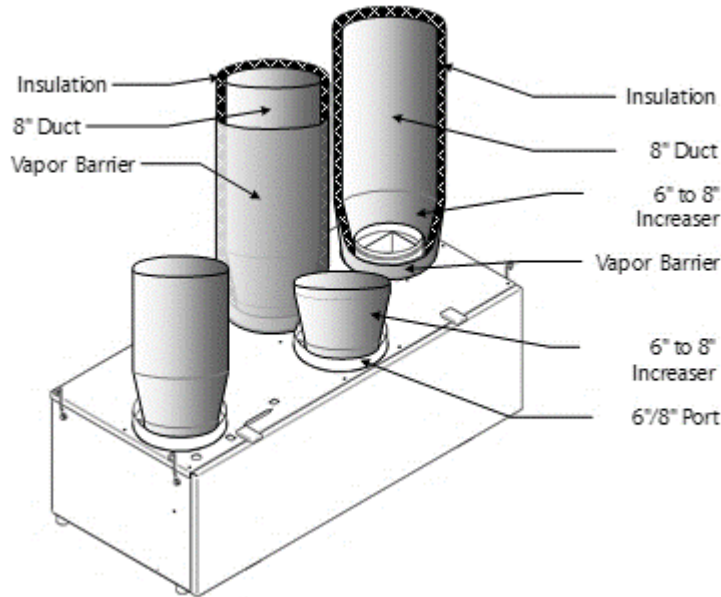

Figure 12 – Efficient airflow and easy installation of insulation sleeve using 6" to 8" increasers.

- It is recommended to install a section of acoustic flexible duct measuring about 3 ft. (1 m) at the end of each supply run to reduce ventilation noise and ensure optimal soundproofing of the distribution network (see next figure). Acoustic flexible duct is nothing more than insulated flexible duct for which the liner was perforated with thousands of tiny holes and which, like a muffler, will absorb the majority of sound waves caused by the air in motion and mechanical components.

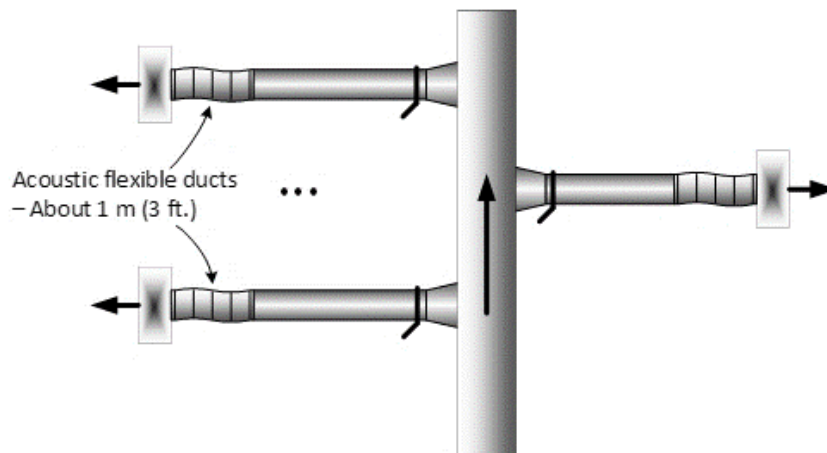

Figure 13 – Install acoustic flexible duct at the end of each supply run.

INSTALLING FLEXIBLE DUCTS

- Generally, flexible ducts should be avoided because they produce a lot of restriction which leads to a higher static pressure (air restriction) inside the ductwork. The higher the static pressure, the more the fans will have to rotate to compensate, which in turn increases ventilation noise and energy consumption.
- If and when you install flexible ducts they must:
 - Be of the highest quality and capable of sustaining a maximum negative static pressure of 1.6" of water column for the return ducts and the fresh air intake,
 - Be as short as possible,
 - Be stretched enough to reduce the internal roughness caused by the duct's natural folds,
 - Not be crushed, and
 - Not have a bend radius inferior to the rigid elbows' bend radius when changing direction. If this is not possible, replace the curved portion by its rigid equivalent and isolate it as required.
- The PEFLEX series of flexible ducts from *Forest Énergie & Air Solutions* (www.feas.ca) are of the highest quality and conform to the Minotair negative static pressure requirement.

VALIDATING THE DUCTS INSTALLATION

- **IMPORTANT!** To avoid problems caused by too much air restriction in ductwork, make sure that the static pressure does not exceed 1.6 inches of water column (400 Pa) when operating in Air Exchanger and Recirculation modes with the unit running at full capacity, depending on the previously selected maximum airflow setting. Use the last screen of the "Ventilation" menu to get the static pressure reading.
- If you get a static pressure greater than 1.6 inches of water column (400 Pa), you must identify the causes of this excessive pressure and apply remedial actions. Possible causes mostly comprise the improper installation of ductwork. For example, the use of undersized conduits, crushed flexible conduits and their non-compliance with the minimum bend radius.

LOCATION OF INDOOR GRILLES

SUPPLY GRILLES

- The air supply grilles must be located and installed in a manner that optimizes air circulation in the rooms.
- Generally, air distribution must be performed through wall grilles. The air supply grilles must be located on the upper part of the wall, at least 1 ft. (30 cm) from the finished ceiling and at least 6 ft. 6 in (2 m) from the floor.
- It is also possible to distribute air through floor registers. However, floor registers do not provide as good air circulation as wall grilles, and can be a source of discomfort for some persons.

RETURN GRILLES

- Generally, air extraction must be performed through wall grilles. The air return grilles must be installed on the upper part of the wall, at least 1 ft. (30 cm) from the finished ceiling and at least 6 ft. 6 in (2 m) from the floor.
- **WARNING!** The return grilles cannot be installed less than 10 ft. (3 m) from a cooking surface. Air extraction from cooking surfaces must be performed by a range hood.
- It is also possible to perform air extraction through floor registers. However, floor registers are prone to capturing debris that could clog the inside of the air return ducts.

LOCATION OF OUTSIDE HOODS

- Outside hoods must be wall type.
- All outside hoods which go through the building envelope must:
 - Be hermetically sealed, on their perimeter, to the sealing system they penetrate.
 - Be equipped with a grid to stop small rodents from entering. This grid must not be too fine, because it could restrict air from passing through and become easily clogged with dust.
- The fresh air intake hood must be located at least 1 ft. 6 in (45 cm) from surfaces where snow may accumulate and at least 6 ft. (1.80 m) from any exhaust air outlet, driveways or any other source of contamination.
- The stale air exhaust hood must be located at least 1 ft. 6 in (45 cm) from surfaces where snow may accumulate and be equipped with an airtight back draft damper.
- Whenever possible, the slope of the conduits connecting to the outside hoods should have a slight slope either towards the outside or the Minotair to drain out condensates that may form if the airflow passing through the conduits is very humid.

BALANCING THE SYSTEM

BALANCING REGISTERS

- All ductwork leading to an air supply or return grille should be equipped with register keys. The keys must be locked and secured mechanically after final balancing (see Figure 9, Figure 10, and Figure 11).
- Where possible, register keys must be installed at least 5 ft. (1.50 m) away from the grilles in order to minimize ventilation noise.
- The last 3 ft. (1 m) of ducts leading to a supply grille would benefit of being made of acoustic flexible ducts in order to further minimize ventilation noise, especially if this is a bedroom.
- It is recommended to keep the register keys accessible through an access panel or a suspended ceiling.
- Grilles with integrated registers should be avoided, because they can be noisy when air passes through them.

BALANCING THE MINOTAIR

- In normal circumstances, the MINOTAIR does not require balancing because its constant airflow fans ensure continuous balancing with a tolerance of $\pm 9\%$ at up to 1.6" water column (400 Pa) of static pressure within the ductwork. This margin of error is within standards.
- For added accuracy or if the building regulations for your area so require, it is possible to further balance the intake and exhaust airflow. This is accomplished by using a differential pressure gauge capable of measuring 0 to ± 0.5 inches of water column (0 to ± 125 Pa) and two flexible plastic tubes.
- **Procedure:**
 - Close all windows and doors, and turn off all exhaust devices such as range hood, dryer and bathroom fans.
 - Set the controller to the maximum airflow allowed, and set the MINOTAIR to "air exchanger" mode.
 - Connect each plastic tube to the fresh air from outside and stale air to outside respectively. To do this, you will need to drill two holes (the size of the tubes) in the ductwork, each at the same distance from the Minotair fan outlets as much as possible.
 - Adjust the airflow of the extraction to make it up to 10% less than or greater than the fresh air intake until the pressure differential reads as close to zero as possible. This setting is accessible in the "Ventilation" menu of the microcontroller.
 - Wait 30 seconds between changes to give the system time to stabilize.
 - Make sure you plug the two holes at the end of the procedure.

SECURING THE MINOTAIR

- The mounting location must be solid enough to support the weight of the device filled with water, in case the drain clogs up, which is a total weight of 120 lb. (55 kg).
- The MINOTAIR must be suspended using the four specially designed hooks. Use the polypropylene webbing straps (supplied) to tie the device.
- Each strap must have its upper part secured by the equivalent of a #10 screw (M5), at least 1¼ in (3 cm) deep. The lower part of the strap is attached to its corresponding hook on one of the MINOTAIR's four corners.
- Ensure there is a space of at least 16" (40 cm) in front of and under the device to open the access panel. If that is impossible, the panel can be removed completely by sliding it to the right. In that case, ensure there is a space to the right of the device of at least 2 in (5 cm).
- Allow for a minimum space of ½ in (1 cm) between the device and the walls. Do not install the device directly against a wall, because the vibrations it makes while functioning will transfer to the building structure and may disturb the occupants. However, if space allows, leave a clearance of 12" to 16" (30-40 cm) at the back of the unit for easy troubleshooting.
- The device must be level after installation in order to allow the condensates to drain properly and to avoid compressor damage.

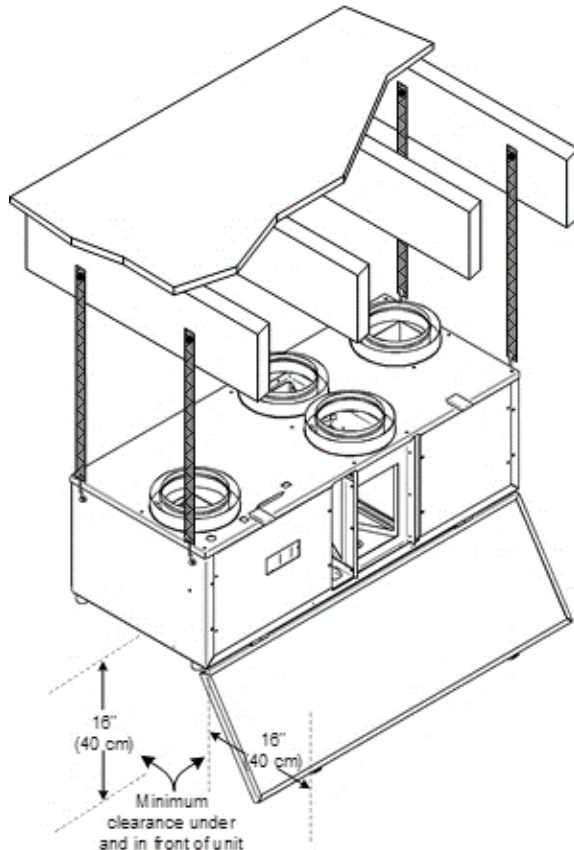

Figure 14 –Mounting the MINOTAIR using the floor joists.

CONNECTING THE CONDENSATE DRAIN

- Connect the female end of the fittings (supplied) to the condensate drains located under the device.
- Connect the male end of the fittings to a $\frac{3}{4}$ in (19 mm) internal diameter flexible tubing (supplied). Then connect the tubing ends to the supplied Tee fitting.
- The Tee fitting must be positioned to form a water trap. The top of the Tee must not be located closer than 6" (15 cm) from the bottom of the device or the drain could clog over time.
- It is recommended to fill the trap with water before starting up the device for the first time in order to avoid suction noises. However, the trap will eventually fill itself up with the accumulation of condensate.
- The other end of the pipe must end its course in the floor drain or a condensate pump. Using a bucket is not recommended, because the MINOTAIR will fill it quickly on humid days, which will then cause spills on the floor.
- Check drain regularly, because if it becomes clogged, water will accumulate in the unit and eventually spill on the floor through the two overflow holes on the sides.
- Using Minotair genuine filters will reduce the risk of small particulates eventually logging the drain.

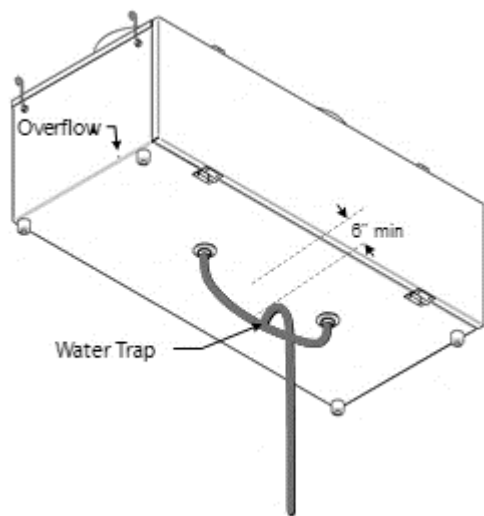

Figure 15 – Position the Tee fitting to form a water trap.

CONNECTING TO AUXILIARY DEVICES (INSTALLATION OPTIONS)

- If one of the two forced air ventilation system installation methods were chosen, the system's ventilator control terminal must be connected to the "G" terminal of the MINOTAIR terminal strip, which will send a 24 VAC signal when it is in operation.
- If the auxiliary heating unit is controlled by the MINOTAIR, the heat generator's control terminal must be connected to the "W" terminal, which will send a 24 VAC signal when the MINOTAIR calls for auxiliary heat.
- If the auxiliary cooling unit is controlled by the MINOTAIR, the air conditioner's control terminal must be connected to the "Y" terminal, which will send a 24 VAC signal when the MINOTAIR calls for auxiliary cooling.
- If the auxiliary humidifier is controlled by the MINOTAIR, its control terminal must be connected to the "H" terminal, which will send a 24 VAC signal when the MINOTAIR calls for humidity.
- If a motorized damper controls a fifth port, its control terminal must be connected to the "5" terminal, which will send a 24 VAC signal when the MINOTAIR operates in Recirculation or Heat Pump modes. In these modes, a fifth port will ensure household odors from the kitchen or bathrooms will not be introduced into the living spaces of the home environment.
- In all cases mentioned above, each device's "common" control wire must be connected to the "C" terminal on the MINOTAIR.

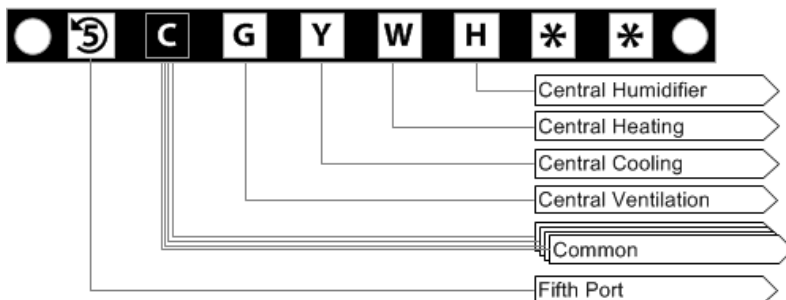

Figure 16 – Connection to a forced air ventilator and other auxiliary devices.

- **CAUTION!** In case the MINOTAIR is connected to a forced air ventilation system, the MINOTAIR's minimum airflow must be confirmed in order to deal with the large pressure differences between the forced air systems and the MINOTAIR. To do this, run the forced-air system ventilator at full speed while running the MINOTAIR at its lowest speed, i.e. 80 cfm (40 l/s), in Air Exchanger mode. Verify that the static pressure reported by the MINOTAIR is greater than or equal to 0.1 inch of water column (25 Pa) (refer to the "ventilation" menu). If it is not (i.e., the pressure is equal to 0.0 inches of water column (0 Pa)), you will need to install a register key (Figure 9 and Figure 10) and adjust it until the static pressure indicates 0.1 inch of water column (25 Pa). That's it! The MINOTAIR constant airflow fans will ensure real time tuning of supply and exhaust airflow from now on.

CONNECTING TO A 5 kW ELECTRIC COIL (INSTALLATION OPTION)

- It is possible to connect an electric coil (duct heater) of a maximum capacity of 5 kW in line with the MINOTAIR main distribution conduit. The selected coil model must be one that is able to modulate its intensity according to the actual airflow and using the coil outlet temperature as the reference point. The reference temperature should be set between 40°C and 50°C (104°F and 122°F) in a heating application or set less than 3°C (37°F) in a preheating application.
- In the case of an electric coil, terminal "W" of the MINOTAIR controls the coil (see Figure 16). Ensure the MINOTAIR auxiliary heating option is set to "YES" in the "Temperature" menu while specifying that the fan source is the MINOTAIR itself and not that of another auxiliary device such as a furnace.
- In the case of an electric coil, its 24 VAC "common" control wire must be connected to the "C" terminal on the MINOTAIR (see Figure 16).

CONNECTING TO AN AUXILIARY HEAT PUMP (INSTALLATION OPTION)

- It is possible to connect a heat pump to the MINOTAIR. In this case, there must be a 120 VAC relay (not supplied) that will connect in parallel with the reversing valve (Terminal NO2 on the microcontroller) located inside the MINOTAIR which will then act as "O" terminal or "B" according to the heat pump model. You have to choose the relay according to whether an "O" terminal (normally open relay) or "B" terminal (normally closed relay) is required.
- In the case of a heat pump, MINOTAIR terminal "W" is used to control the auxiliary heating of the heat pump "AUX", which in this case is essentially the third stage of heating.
- In the case of a heat pump, MINOTAIR terminal "Y" is used to control the compressor "COMP (Y)" of the auxiliary heat pump.
- In the case of a heat pump, its 24 VAC "common" control wire must be connected to the "C" terminal on the MINOTAIR.

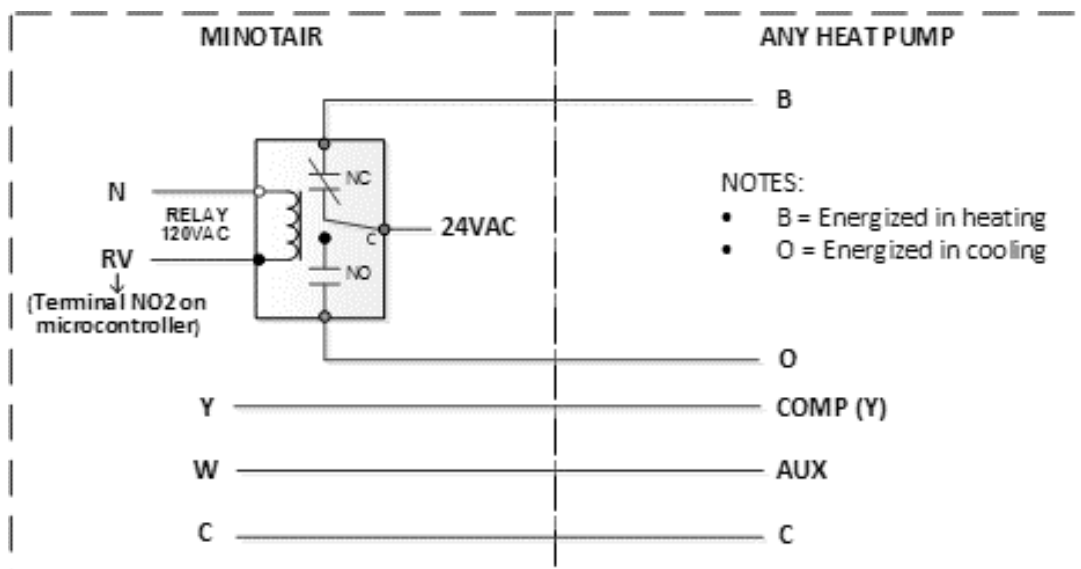

Figure 17 – Connection of a heat pump to the MINOTAIR.

- **Dry contact-controlled equipment.** In cases where a device must be controlled through dry contacts – as is often the case with humidifiers – a relay (not supplied) must be added, to be activated by the 24 VAC signal sent by the corresponding terminal and whose “normally open” and “common” contacts will connect to the dry contact terminal of the device in question (Figure 18).

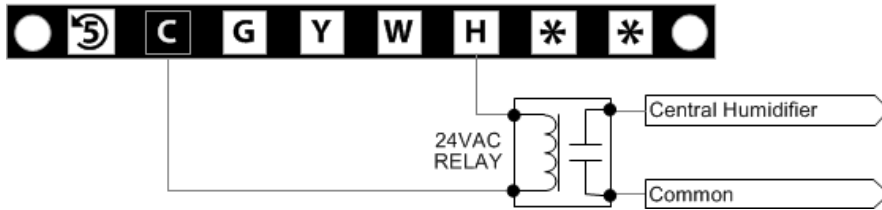

Figure 18 – Connecting to a dry contact controlled humidifier with the use of a relay.

CONNECTING TO A BATHROOM TIMER (INSTALLATION OPTION)

- Bathrooms can be equipped with timers to activate ventilation in air exchanger mode when needed.
- The MINOTAIR timers can be turned on for periods of 10, 20 or 30 minutes. They can remain continuously turned on by simply pressing their button for 3 seconds.
- Up to 10 timers can be installed in parallel.
- **CAUTION!** Never apply electrical voltage on starred (*) terminals, because this will irreparably damage the microcontroller and will not be covered by the warranty.

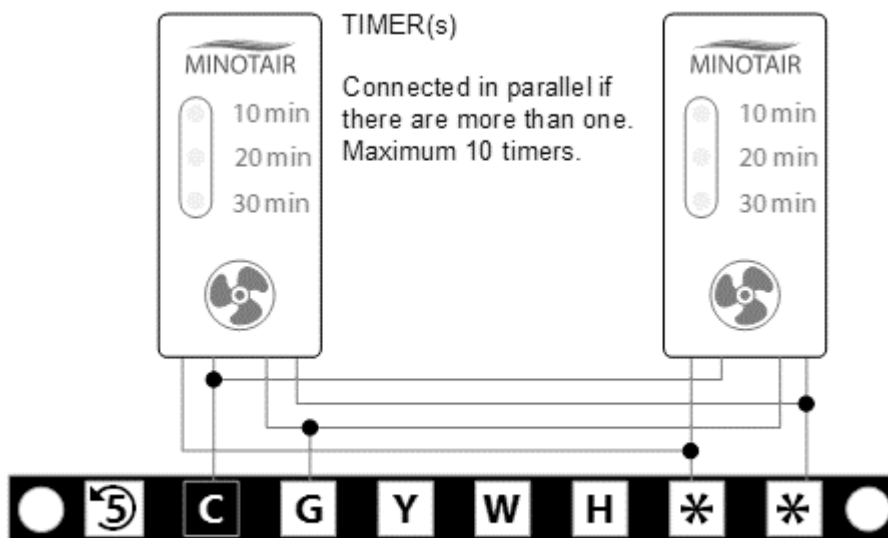

Figure 19 – Connecting bathroom timers.

INSTALLING THE WALL MOUNT CONTROL (INSTALLATION OPTION)

- In addition to the digital control integrated in the microcontroller, it is possible to connect up to two wallmount digital controls per MINOTAIR unit for even more convenience.

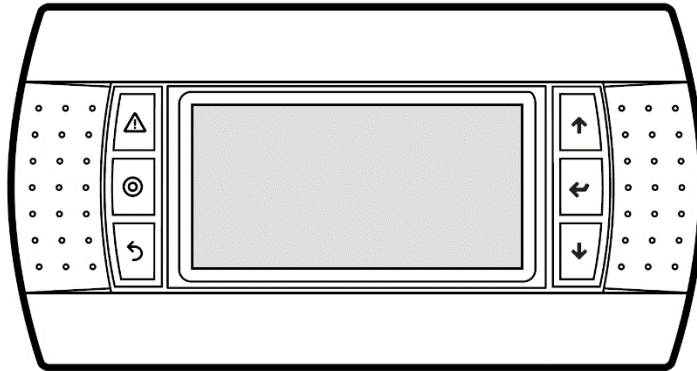

Figure 20 – Wall Mount Digital Control

SELECTING THE LOCATION

- Note that there are no temperature or humidity sensors in the wall mount control, which means it can be installed just about anywhere. However, we recommend an easily accessible location where it can often be consulted. For example, hallways leading to the bedrooms, the living room or the dining room are good locations.
- The digital control is installed on the wall using four screws (supplied). The height should be chosen to facilitate reading.

ADJUSTING DISPLAY CONTRAST

- Once the digital control is installed, it is possible to adjust its contrast. To do so, hold down both Δ + \odot keys and use \uparrow or \downarrow to increase or decrease contrast on the digital control.

CABLE CONFIGURATION

- Connecting a wall mount digital control is done using a 6-wire telephone cable.
- The connectors must be 6-position RJ12 (6P6C) type.
- Maximum cable length for connections is 150 ft. (45 m).
- One end of the cable connects to the back of the digital control, while the other end connects to the 6-position jack labelled “MINO-CONTROL”, located on top of the MINOTAIR.

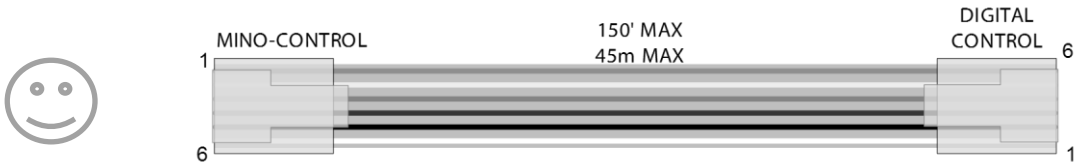

Figure 21 – Cable configuration for a single wall mount digital control

- **Warning!** Be sure not to cross endings, as this will render all communications with the microcontroller impossible. Note that this will not damage the digital control, but a *NO LINK* message will appear.

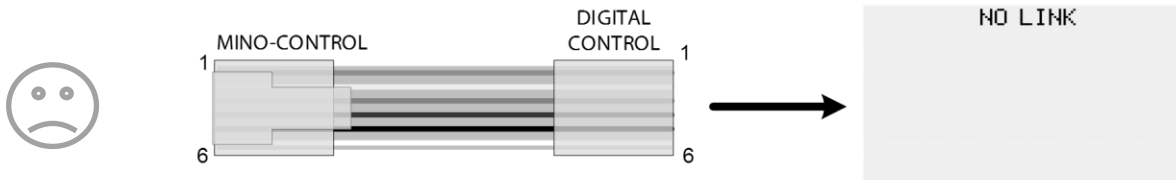

Figure 22 – Wrong configuration

- If the installation includes two wallmount digital controls, a cable splitter (optional) must be connected into the “MINO-CONTROL” jack located on top of the device. This will double the “MINO-CONTROL” jack so that each control can have its own cable.

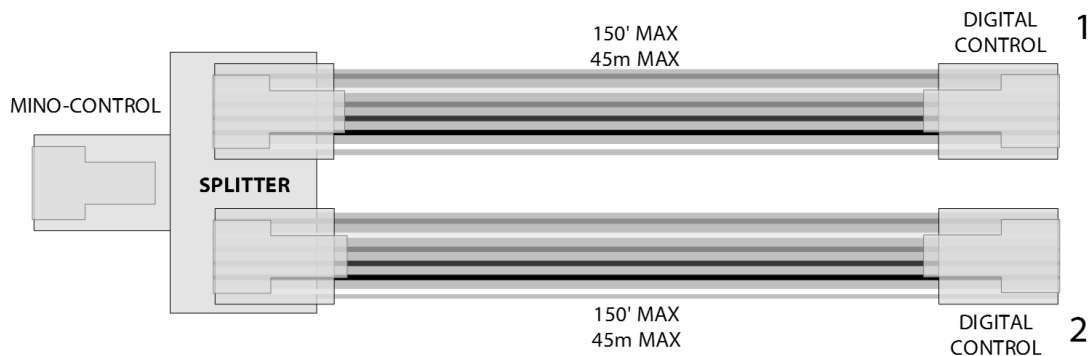

Figure 23 - Cable configuration for two wallmount digital controls

WALL-MOUNTING

- The digital control consists of three main parts (A, B, C in Figure 24):
 - A. The back piece,
 - B. The electrical board and
 - C. The snap-on cover.
- Before mounting, you must disassemble the digital control. To do this, use your fingers to lift one corner of the snap-on cover **C** until it comes off. Be careful not to lose the small black plastic frame around the screen, and be sure to memorize its position to facilitate reassembly later.
- For wall-mounting, you must first affix the back-piece **A** in one of two ways:
 1. On an electrical box. In this case, use the corresponding rounded-head screws (supplied) and make sure the electrical box is mounted horizontally, or
 2. Directly onto the wall. In this case, use the plastic pins (supplied), as required, and the corresponding rounded-head screws (supplied).
- Ensure the back-piece **A** is level.
- Then proceed to connect the phone cable by passing it through the square opening of the back-piece **A** and inserting the connector into the terminal of the electric board **B**.
- Rest the electrical board **B** on the back-piece **A** and fasten the parts together using the flush-head screws (supplied) made for plastic.
- Finally, put back the small black plastic frame around the screen, and fit the snap-on cover **C**.

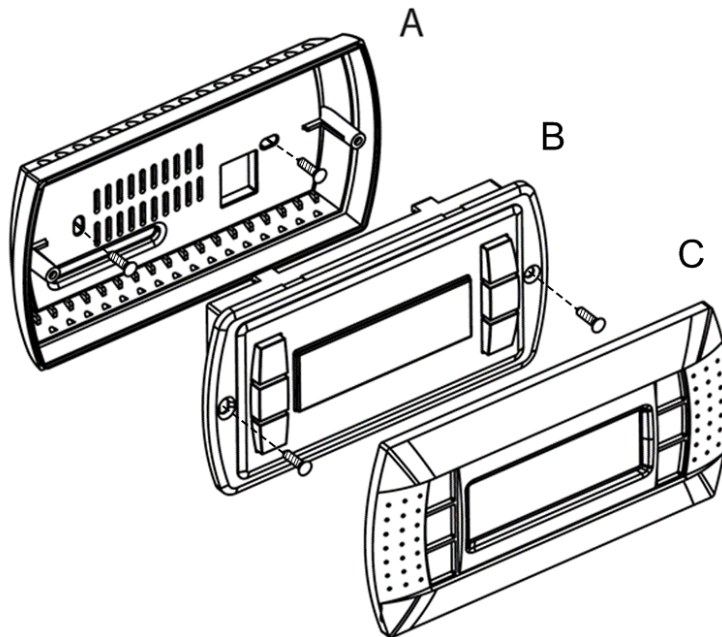

Figure 24 – Wall-Mounting

CONNECTING THE MINOTAIR

- This is the last step before powering on the MINOTAIR.
- A 120 VAC/15A circuit must be used and the connection must be made by a qualified electrician. It is always advised to install a wall switch nearby the MINOTAIR that can be used to cut power during repair or maintenance activities (Figure 25).
- No other device can share the same circuit as the MINOTAIR. If a condensate pump is required, it must be connected to a different circuit.

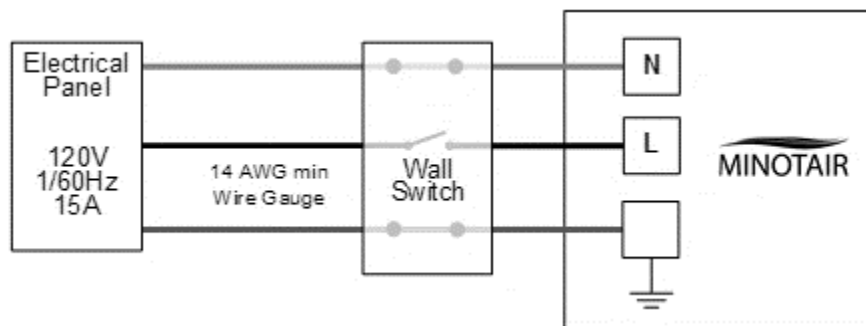

Figure 25 – Connecting the device.

- **IMPORTANT!** If you suspect the electrical source to be of poor quality (i.e. subject to voltage variations, spikes, brownouts, electrical noise, etc.), it is recommended to install a surge protector to avoid damages to the sensible electronics contained in the microcontroller and the fans. The surge protector can be one that is dedicated to the MINOTAIR or one for the whole house that will be installed in the electrical panel and will also protect all the electronic devices contained in the house.

DIGITAL CONTROL BASICS

The MINOTAIR is controlled through a digital control featuring a backlit display and 6 buttons. The interface is designed around a house theme.

MAIN SCREEN

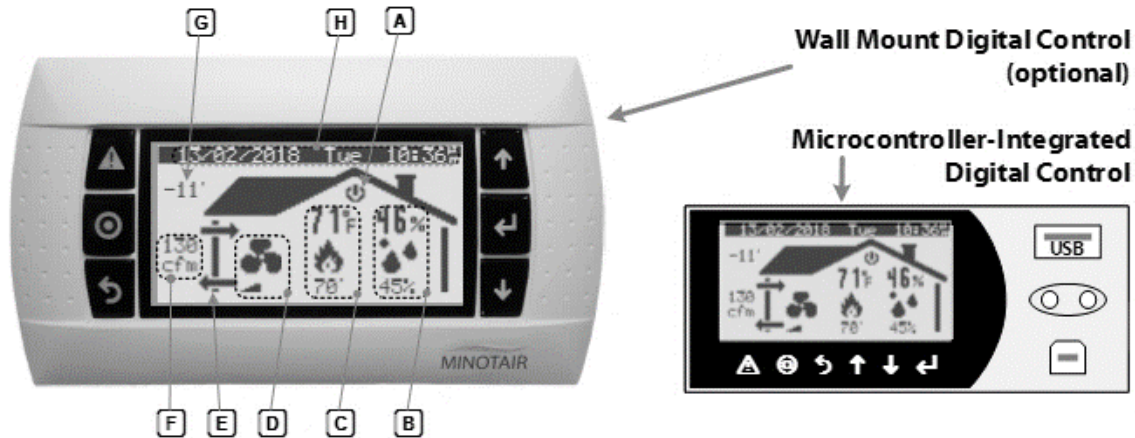

Figure 26 – MINOTAIR digital control main screen¹.

Inside the house

- A Device status {on (⏻), off (⏻)}²
- B Indoor relative humidity level in bold, with setpoint humidity displayed under.
- C Indoor temperature in bold {71°F}, icon indicating the temperature control mode {heating, cooling}, with setpoint temperature displayed under.
- D Ventilation speed {low, high}.
- E Ventilation mode {Air Exchanger, Recirculation, Heat Pump, and Intermittent 10/20/30/40, Smart}.

Outside the house

- F Current airflow {cfm (cubic feet per minute), l/s (liters per second)}.
- G Outside temperature with its trend {▲ (upward), ▬ (stable), ▼ (downward)}.
- H Date, day of the week and current time.

¹ For information purposes only. The actual screen may differ from the image shown here. For simplicity, only the wall mount control is used in subsequent examples. However, the principles are equally applicable to the microcontroller-integrated digital control.

² The values shown within brackets represent the available options. The underlined option is the option used in the example.

DIGITAL CONTROL BUTTONS

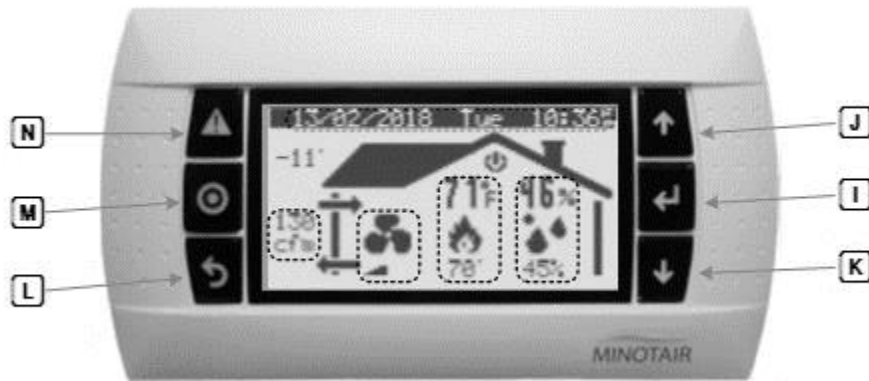

Figure 27 – Buttons of the digital control.

- I The “Enter” \leftarrow button changes a value or allows a value to be changed by the “Up” \uparrow and “Down” \downarrow arrows.
- J The “Up” \uparrow button increases a value or moves the cursor up.
- K The “Down” \downarrow button decreases a value or moves the cursor down.
- L The “Escape” \curvearrowright button returns to the previous screen.
- M The “Setpoint” \odot button serves to set the temperature and humidity. If depressed for 3 seconds, it displays the main menu to adjust system settings.
- N The “Alarm” \triangle button displays the state of various alarms if applicable. It is also used to turn on and off the unit.

NOTE: The buttons light up when pressed. They shut off after 10 minutes of idle time.

NOTE: The screen lights up when a button is pressed. It shuts off after 10 minutes of idle time, unless it is configured to always stay backlit. This setting is accessible from the main menu.

NOTE: The “Alarm” \triangle button flashes red to indicate an alarm. By pushing on it, the corresponding message will display and the system will reset the alarm if the conditions that triggered it are no longer present. If the conditions remain, the button will continue to light up. Note that each alarm is logged in the events log. If there is more than one simultaneous alarm, they can be reviewed in the log one after the other using the \uparrow and \downarrow arrows.

LISTING OF SYMBOLS

The digital control uses symbols to represent the current state of different functions. For example, a static flame indicates that the device is ready to call for heat while an animated flame means that heating is occurring.















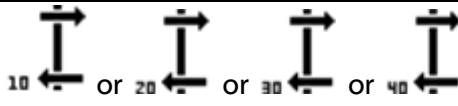



Ventilation					
 On  Off	 Low Speed	 High Speed	 Intermittent Mode		
 Air Exchanger Mode	 Heat Pump Mode	 Recirculation Mode	 Smart Mode		
Temperature					
 Heating	 Auxiliary Heating	 Cooling	 Auxiliary Cooling	 Free Cooling	 Turbo Cooling
Humidity					
 Dehumidification		 Humidification		 Winter Conditions	
7-Day Program					
 Day Setpoint		 Night Setpoint		 Away Setpoint	
Various					
 Exception, Alarm or Self-Diagnostic		 Defrost	 Compressor Pause	 Bathroom Timer	

Table 3 – Animated symbols used for various MINOTAIR features.

ADJUSTING DISPLAY CONTRAST

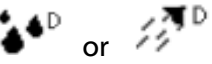
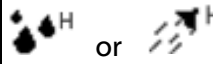
Integrated Control: Hold down both \curvearrowright + \curvearrowleft buttons and use \uparrow or \downarrow to increase or decrease contrast on the digital control.

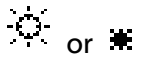
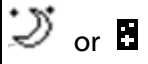
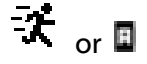
Wall mount Control: Hold down both Δ + \odot buttons and use \uparrow or \downarrow to increase or decrease contrast on the digital control.

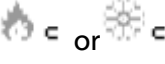
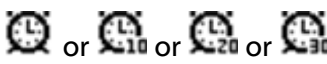
BOOT SEQUENCE

Like most computers, every time you power on the MINOTAIR or after a power outage, the MINOTAIR initiates a boot sequence that lasts approximately 30 seconds. During this period, the digital control is not in operation and the screen may be blank or display messages like "No Link". Once the boot sequence is complete (Figure 28), the device will resume its operation as it was before it was rebooted or lost power, and will remember its settings.



Figure 28 – 30-second boot sequence screen.

NOTE: If the device is turned on for the first time or if you have just updated the microcontroller, you may be asked to cut power to the MINOTAIR for 30 seconds (Figure 29) by closing the circuit breaker or the circuit switch. This procedure is normal. Switch power back on after 30 seconds.

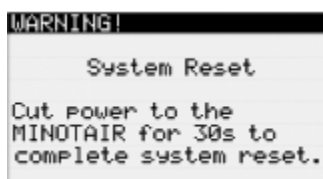

Figure 29 – Switch off power to the MINOTAIR when requested.

TURNING THE DEVICE ON AND OFF

Press Δ to turn on the device. Ventilation will start (Figure 30).

NOTE: The MINOTAIR does not display temperature or humidity when it is turned off. The MINOTAIR's ventilation must be in operation for this information to show.

NOTE: The MINOTAIR does not control auxiliary heating and cooling units when it is turned off. The MINOTAIR's ventilation must be in operation to control these devices.

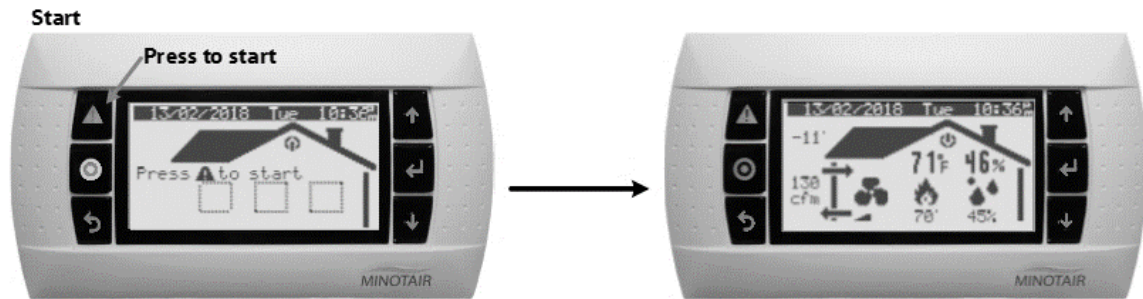

Figure 30 – To turn on the MINOTAIR, press Δ .

To turn off the device, simply hold down the Δ button for 3 seconds. Ventilation will stop and the screen becomes as shown on Figure 31.

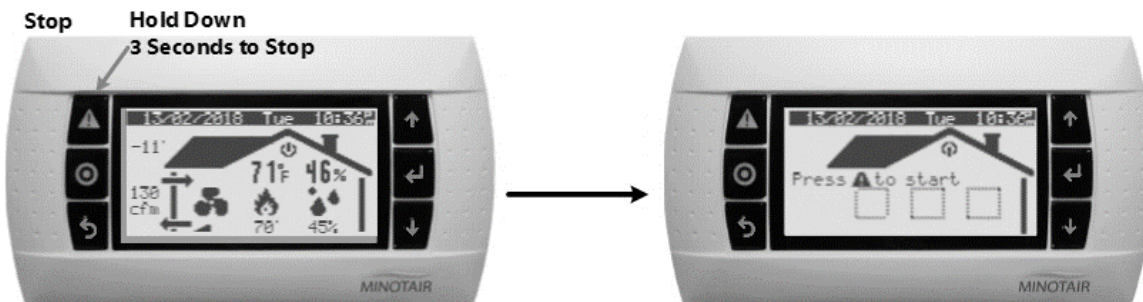







Figure 31 – To turn off the MINOTAIR, hold down Δ for 3 seconds.

ADJUSTING INDOOR TEMPERATURE

Press the setpoint button  once.

Press  to move the cursor to the temperature setpoint of the current mode. Press  to display two arrows "↑ ↓" making it possible to increase or decrease the setpoint using the  and  buttons. After 5 seconds of inactivity or pressing a second time on  disables the arrows.

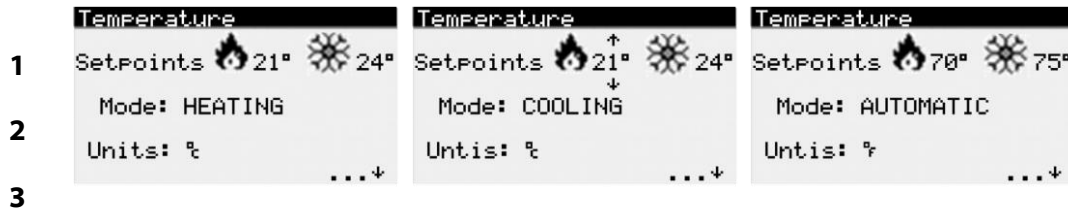



Figure 32 - Examples of options to adjust the temperature setpoint, mode and units.

1 Setpoints:

- . Desired setpoint when the device is in heating mode. To change this value, the mode must be set to "HEATING". In Automatic mode, the heating setpoint must always be lower or equal to the cooling setpoint. The device will automatically correct it, if needed.
- . Desired setpoint when the device is in cooling mode. To change this value, the mode must be set to "COOLING". In Automatic mode, the cooling setpoint must always be higher or equal to the heating setpoint. The device will automatically correct it if needed.

2 Mode:

- **HEATING.** The device will only function in heating mode.
- **COOLING.** The device will only function in cooling mode.
- **AUTOMATIC.** The device will function in either heating or cooling mode, depending on the season. It switches between modes based on a sophisticated algorithm that protects against false changes of season. For example, in the winter, the device will avoid switching to cooling mode even if a secondary heating source (fireplace, woodstove, etc.) heats the house over the setpoint temperature.

3 Units:

- **°C.** Temperature will display in Celsius units
- **°F.** Temperature will display in Fahrenheit units.

ADJUSTING INDOOR RELATIVE HUMIDITY

Press the setpoint button Ⓞ twice.

Press ↑ or ↓ to increase or decrease the relative humidity setpoint.

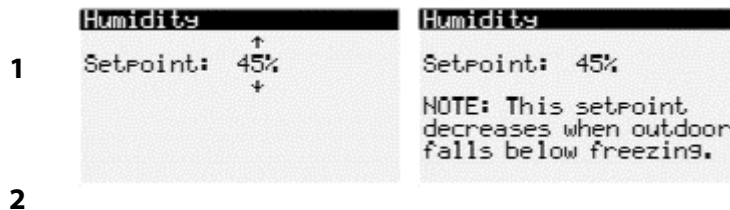

Figure 33 – Adjusting the humidity setpoint and the effect of automatic winter decrease.

1 Setpoint:

- **30% to 60%.** Set the desired relative humidity. During the winter months, a 35% indoor humidity level is ideal (30-40%), while a 45% indoor humidity level is very comfortable (40-60%).

2 NOTE:

- If humidity was set to *winter automatic mode* in the main menu, the setpoint displayed on the main screen will automatically decrease as the outside temperature falls below freezing, but without ever going under 30%.

ACTIVATE THE VIRTUAL BATHROOM TIMER

Hold down the escape button ⏪.

Press the setpoint button ⊙ once to activate the timer for 10 minutes.

Press the setpoint button ⊙ a second time to activate the timer for 20 minutes.

Press the setpoint button ⊙ a third time to activate the timer for 30 minutes.

Press the setpoint button ⊙ a fourth time to stop the timer.

Note that physical bathroom timers always take precedence over the virtual timer.

Note also that the bathroom timer ventilation speed is set in the Main menu.



Figure 34 – Activation of the Virtual Bathroom Timer is done by pressing ⏪ and ⊙.

MAIN MENU

The MINOTAIR includes several settings that are accessible from the main menu screen. You can access the main menu by pressing the “Setpoint” Ⓞ button for 3 seconds.

1. VENTILATION SETTINGS

Press the Ⓞ button for 3 seconds to display the main menu. Then, using the ↑ and ↓ arrows, navigate to the “Ventilation” submenu and press ↵ to select (Figure 35).

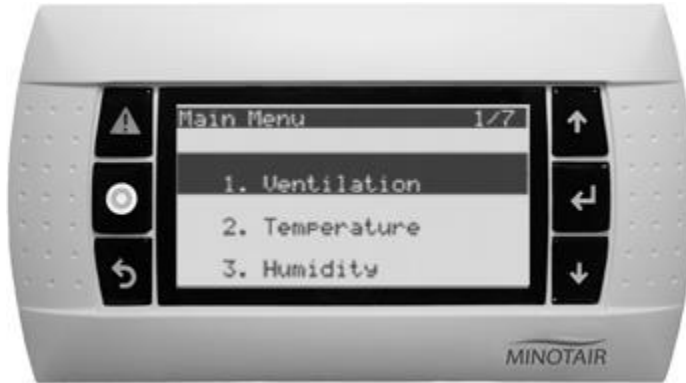

Figure 35 – Main menu – Ventilation settings.

“VENTILATION” SETTINGS SCREEN

There are 11 available options displayed over several screens. Press ↓ or ↑ to move the cursor between options. Once the desired option is selected, press ↵ to change the setting (Figure 36).

The following options are available:

	Ventilation	Ventilation	Ventilation
1.1	Mode: AIR EXCHANGER	Mode: RECIRCULATION	Mode: HEAT PUMP
1.2	Fresh Air: 20 cfm	Fresh Air: 40 l/s	Fresh Air: 120 cfm
1.3	Units: cfm ...↑	Units: l/s ...↑	Units: cfm ...↑

Figure 36 – Examples of options to adjust ventilation mode, fresh air setpoint and units.

1.1 Mode:

- **AIR EXCHANGER.** The device ventilates and continuously renews the air. It filters air while removing pollutants from the house and oxygenates indoor air with fresh air from outside. It dehumidifies and cools air in the summer, and dehumidifies and recovers heat in the winter.
- **HEAT PUMP.** The device recirculates the air keeping heat indoor in the winter, and coolness in the summer. It dehumidifies and cools air in the summer and heats air in the winter. It filters air while providing uniform humidity and temperature conditions. The device does not renew air in this mode.

- **RECIRCULATION.** The device recirculates and filters air while providing uniform humidity and temperature conditions. This mode consumes very little energy because it does not heat or cool. The device does not renew air in this mode.
- **SMART.** The device prioritizes air exchanger mode and switches to heat pump mode during calls for heat or cooling. Switches to recirculation mode when weather conditions are unsuitable for air exchanger or heat pump modes.
- **INTERMITTENT – 10, 20, 30, 40.** Alternates between air exchanger and recirculation modes in order to provide fresh air over a predefined period of time varying between 10, 20, 30 and 40 minutes per hour. Intermittent-10 mode is ideal during long absences in which the house is unoccupied.

1.2 Fresh Air Setpoint:

- **20 to 180 cfm (10 to 85 l/s).** Set the ventilation supply rate according to the fresh air requirement of the house³.

NOTE: It is important to choose a ventilation supply rate that corresponds to the house's requirements. A low supply rate can lead to a decrease in comfort and indoor air quality. On the other hand, a high supply rate can dry out the air and cause cracks in the wood, as well as increasing heating and cooling costs.

1.3 Units:

- **cfm.** Ventilation speed will display in cubic feet per minute.
- **l/s.** Ventilation speed will display in liters per second.

³ Use the fresh air supply rate calculated in Table 1 – Airflow planning.

“VENTILATION” SETTINGS SCREEN (CONT’D)

	Ventilation ...↑	Ventilation ...↑
1.4	Recirculation Mode Default Speed: LOW	Recirculation Mode Default Speed: HIGH
1.5	Bathroom Timers and Shower : TURBO Detector Speed. ...↑	Bathroom Timers and Shower : TURBO Detector Speed. ...↑

Figure 37 – Examples of options to adjust the default bathroom timers and recirculation speed.

1.4 Recirculation Mode Default Speed:

- **LOW.** Ventilation speed will be equal to the configured fresh air setpoint in the previous “Ventilation” screen, but never less than 80 cfm (40 l/s).
- **HIGH.** Ventilation speed will be double the configured setpoint in the previous “Ventilation” screen, but not more than the device’s upper limit and but never less than 80 cfm (40 l/s).

1.5 Bathroom Timers and Shower Detector Default Speed:

- **TURBO.** Ventilation speed will be the maximum airflow rate allowed by the machine 180 cfm – 250 cfm (85 l/s – 120 l/s). This cannot be changed.

“VENTILATION” SETTINGS SCREEN (CONT’D)

	Ventilation ...↑	Ventilation ...↑
1.6	Stop exchanging air in winter if or if:	Stop exchanging air in winter if or if:
1.7	Out. temperature <-20° Humidity too low : YES ...↑	Out. temperature <-04° Humidity too low : NO ...↑

Figure 38 – Examples of options to adjust winter limits.

1.6 Air exchanger mode outside temperature limit:

- **-30°C to 0°C (-22°F to 32°F).** This setting applies to air exchanger mode during winter months. Set the minimum outside temperature at which the device will stop ventilation in air exchanger mode. The device will then switch to recirculation mode and display an exception symbol [!].

1.7 Indoor humidity too low:

- **YES.** When indoor humidity drops below setpoint, the device will stop ventilation in air exchanger mode. The device will then switch to recirculation mode and display an exception [!].
- **NO.** When indoor humidity drops below setpoint, the device will continue to ventilate per normal but at the risk of further drying out the indoor air.

“VENTILATION” SETTINGS SCREEN (CONT’D)

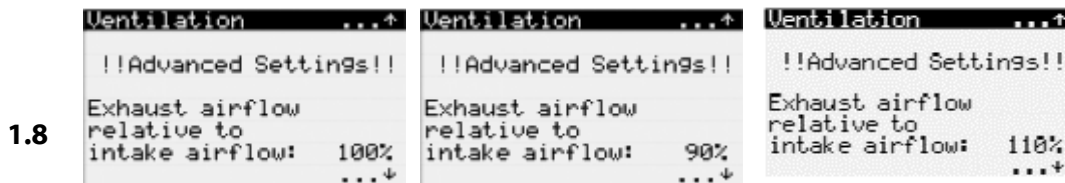

Figure 39 – Examples of options to adjust exhaust airflow.

1.8 Exhaust airflow relative to intake airflow:

- **90% to 110 %.** Set the exhaust fan airflow to make it lower or higher than the intake fan airflow in order to balance the airflows with greater accuracy. See "Balancing the MINOTAIR" for more information.

NOTE: This is an advanced setting and only ventilation professionals equipped with proper measuring equipment should adjust it.

“VENTILATION” SETTINGS SCREEN (CONT’D)



Figure 40 – Examples of options to adjust the maximum airflow.

1.9 Maximum Airflow:

- **250 cfm – 180 cfm (120 l/s – 85 l/s).** Adjust this setting to the highest airflow rate that will allow the static pressure to remain lower than or equal to 1.6" WC when the unit is operating in either Air Exchanger mode and Recirculation mode at High speed. Start by setting the Minotair to Recirculation mode at High speed with a Fresh Air setpoint of 125 cfm (60 l/s), i.e. will run at 250 cfm (120 l/s) at High speed. Adjust for the highest airflow by waiting 30 seconds between each adjustment. Once you are satisfied with the setting, trigger the bathroom timer to switch to Air Exchanger mode. Readjust the maximum airflow setting downward if the static pressure becomes higher than 1.6" WC. Once done, do not forget to readjust the Fresh Air setting as required.
- **See next page to determine the static pressure.**

“VENTILATION” SETTINGS SCREEN (CONT'D)

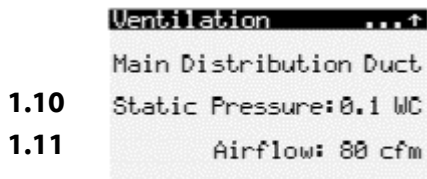

Figure 41 – Static pressure at current airflow.

1.10 Static Pressure:

- This setting screen is useful when you want to validate the ducts installation generates less than 1.6 inches of water column.
- This setting screen is also used to validate the connection of the main air distribution duct to the main return of a forced air ventilation system. Indeed, due to significant differences in pressure between the MINOTAIR and the forced-air system ventilator it is being connected to, the MINOTAIR's minimum airflow must be confirmed. To do this, run the forced-air system ventilator at full speed while running the MINOTAIR at its lowest speed, i.e. 80 cfm (40 l/s), and verify that the static pressure reported by the MINOTAIR is greater than or equal to 0.1 W.C. (25 Pa). If it is not (i.e., the pressure is equal to 0.0 W.C. (0 Pa)), you will need to install a register key and adjust it until the static pressure indicates 0.1 W.C. (25 Pa). Once adjusted, the MINOTAIR constant airflow fans will ensure real-time calibration of supply and exhaust airflows from now on.

NOTE: The static pressure is displayed only in inches of Water Column (W.C.)

1.11 Airflow Rate:

- The airflow rate currently in progress for information purposes.
NOTE: The airflow is displayed only in cfm units.

2. ADJUSTING HEATING AND COOLING SETTINGS

Press the **⊙** button for 3 seconds to display the main menu (Figure 42) and use the **↑** and **↓** arrows to navigate to the “Temperature” submenu. Press **↵** to select.



Figure 42 – Main menu – Temperature settings.

“TEMPERATURE” SETTINGS SCREEN

There are 8 available options displayed over several screens. Press **↓** or **↑** to move the cursor between options. Once the desired option is selected, press **↵** to change the setting (Figure 43).

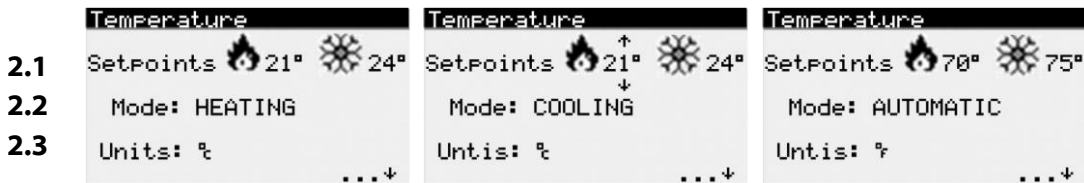

Figure 43 - Examples of options to adjust the temperature setpoint, mode and units.

2.1 Setpoints:

- Desired setpoint when the device is in heating mode. To change this value, the mode must be set to “HEATING”. In Automatic mode, the heating setpoint must always be lower or equal to the cooling setpoint. The device will automatically correct it, if needed.
- Desired setpoint when the device is in cooling mode. To change this value, the mode must be set to “COOLING”. In Automatic mode, the cooling setpoint must always be higher or equal to the heating setpoint. The device will automatically correct it, if needed.

2.2 Mode:

- **HEATING.** The device will only function in heating mode.
- **COOLING.** The device will only function in cooling mode.
- **AUTOMATIC.** The device will function in either heating or cooling mode, depending on the season. It switches between modes based on a sophisticated algorithm that protects against false changes of season.

2.3 Units:

- **°C.** Temperature will display in Celsius units
- **°F.** Temperature will display in Fahrenheit units.

"TEMPERATURE" SETTINGS SCREEN (CONT'D)



Figure 44 – Examples of options to adjust auxiliary (central) heating units.

The MINOTAIR can control auxiliary heating units such as electric and gas furnaces and heat pumps as long as they can be controlled through a 24 VAC signal.

NOTE. Forced air units must be connected to the "G" terminal to synchronize ventilation with that of the MINOTAIR.

2.4 Auxiliary Heating?

- **NO.** The MINOTAIR does not control any auxiliary heating unit.
- **YES.** The MINOTAIR controls an auxiliary heating unit. The control signal follows a call for heat for which the MINOTAIR was unable to reach the requested temperature setpoint within 5 to 25 minutes depending on outside air temperature, or if indoor temperature is 1°C (1.8°F) under the temperature setpoint.

2.4.1 Fan Source:

- **MINOTAIR.** The MINOTAIR controls a 5 kW electric coil (not supplied) in line with its distribution conduit. The control signal is a 24 VAC voltage to the "W" terminal. See "Connecting to a 5 kW Electric Coil (Installation Option)" for further details.
- **AUXILIARY.** The MINOTAIR sends a heating signal to the heating terminal "W" located on the connection terminal block and will let the auxiliary unit manage the transition from one stage to another if appropriate. In the case of a heat pump, the signal will rather come from the "Y" terminal. See "Connecting to an Auxiliary Heat Pump (Installation Option)" for further details.

2.4.2 Lockout:

- **Setpoint.** In the case of a heat pump, the MINOTAIR uses the lockout temperature to determine the limit at which the heat pump will cease to function and instead favor the auxiliary or emergency heat controlled by terminal "W". The lockout setpoint is also used to determine when to call upon the auxiliary heating if the heat pump was unable to reach the desired temperature setpoint within 5 to 25 minutes depending on the outside temperature. See "Connecting to an Auxiliary Heat Pump (Installation Option)" for further details.

"TEMPERATURE" SETTINGS SCREEN (CONT'D)

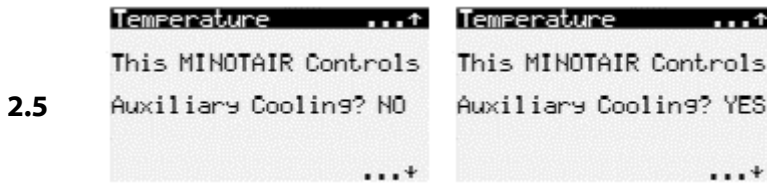

Figure 45 – Examples of options to adjust auxiliary cooling units.

The MINOTAIR can control auxiliary cooling units such as air conditioners and heat pumps as long as they can be controlled through a 24 VAC signal. When these devices are forced air systems, the MINOTAIR can control their ventilation.

NOTE. Forced air units must be connected to the "G" terminal to synchronize ventilation with that of the MINOTAIR.

2.5 Auxiliary Cooling?

- **NO.** This MINOTAIR does not control any auxiliary cooling unit.
- **YES.** This MINOTAIR will send a signal to the "Y" cooling terminal on the terminal board and will let the auxiliary unit manage its own speed switching, if applicable. This signal follows a cooling call for which the MINOTAIR was unable to reach the requested temperature setpoint within 5 to 20 minutes depending on the outside air temperature, or if indoor temperature is 1°C (1.8°F) over the temperature setpoint.

"TEMPERATURE" SETTINGS SCREEN (CONT'D)



Figure 46 – Examples of options to adjust a remote sensor.

2.6 Use of a remote sensor?

- **NO.** This MINOTAIR uses its internal sensor.
- **YES.** For greater indoor temperature accuracy, this MINOTAIR uses a remote sensor. This option only appears if the MINOTAIR controls an auxiliary heating or air conditioning system.

"TEMPERATURE" SETTINGS SCREEN (CONT'D)

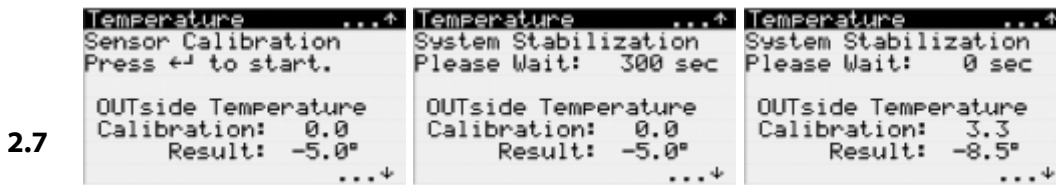

Figure 47 – Examples of options to adjust outside temperature calibration.

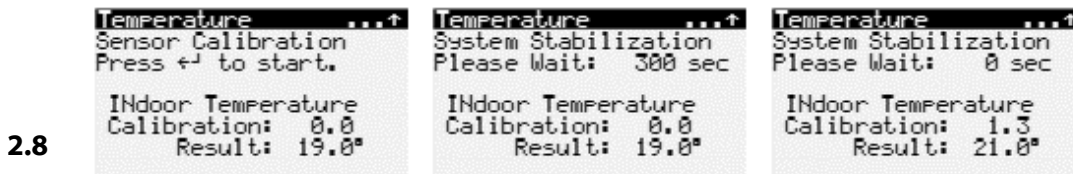

Figure 48 – Examples of options to calibrate the inside temperature sensor.

The MINOTAIR uses sensors to measure outside and indoor temperatures. However, since the sensors are integrated into the device, their temperature readings may differ from what the sensors would have measured if they had been located outside the house (for outside temperature) or in a living space like the living room (for indoor temperature). In fact, temperatures measured by each sensor will be directly impacted by the air intake duct's level of insulation and airflow rate.

To compensate for this discrepancy, the MINOTAIR temperature sensors must be calibrated. The calibration process is performed once the device's installation is complete. For best results, a difference of at least 10°C (20°F) between outside and indoor temperatures is preferred when calibrating. The greater the difference, the more precise the calibration will be.

2.7 Calibrating outside temperature. Press \leftarrow to start the calibration process. The device will take 300 seconds to stabilize. During this time, measure the outside temperature with a thermometer. Once the device is stable, press \leftarrow to display two arrows " $\uparrow \downarrow$ " making it possible to increase or decrease the setpoint using the \uparrow and \downarrow buttons. Increase the calibration value until the result value is equal to the temperature measured with the thermometer. A normal calibration value should range between 1.0 and 8.0. If the value is much more than this, indoor air is likely infiltrating the intake duct (check the ductwork) or the temperature sensor is defective.

2.8 Calibrating indoor temperature. If the device has already been stabilized, it is not necessary to wait 300 seconds again. After measuring the indoor temperature with a thermometer, press \leftarrow to display two arrows " $\uparrow \downarrow$ ". Increase the calibration value until the result value is equal to the temperature measured with the thermometer. A normal calibration value should range between 0.1 and 5.0. If the value is much more than this, cold air is likely infiltrating the return ducts (check the ductwork) or the temperature sensor is defective.

3. ADJUSTING INDOOR HUMIDITY SETTINGS

Press the **⊙** button for 3 seconds to display the main menu and use the **↑** and **↓** arrows to navigate to the “Humidity” submenu. Press **←** to select (Figure 49).



Figure 49 – Main menu – Humidity settings.

“HUMIDITY” SETTINGS SCREEN

There are 4 available options displayed over several screens. Press **↓** or **↑** to move the cursor between options. Once the desired option is selected, press **←** to change the setting (Figure 50).

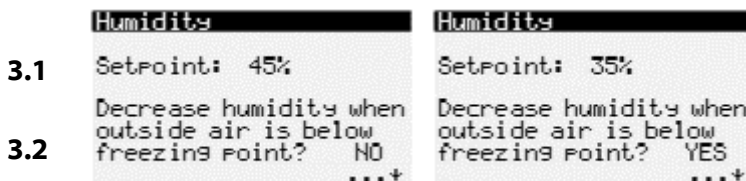

Figure 50 – Examples of options to adjust humidity settings and automatic winter adjustment.

3.1 Setpoint:

- **30% to 60%.** Set the desired relative humidity. During the winter months, a 35% indoor humidity level is ideal (30-50%), while a 45% indoor humidity level is very comfortable (40-60%). At all time, the indoor humidity setpoint may be hard to maintain if your house is not airtight.

3.2 Decrease humidity if outside air is below freezing point?

- **YES.** When outside temperature falls below freezing, the humidity setpoint will progressively decrease to reach 35 % at -15°C (5°F), and as low as 30% at -20°C (-4°F) or less. Humidity level cannot be set below 30% for reasons of comfort and health.
- **NO.** The humidity setpoint will remain unchanged if outside air falls below freezing point.

"HUMIDITY" SETTINGS SCREEN (CONT'D)

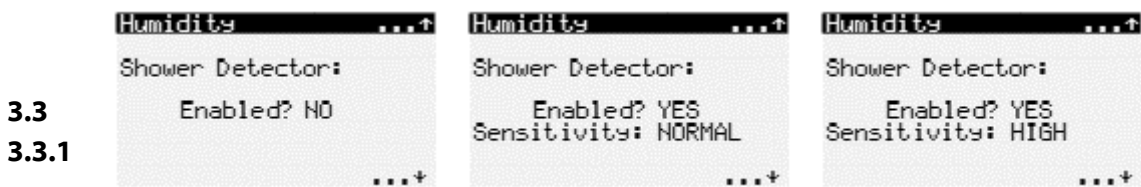

Figure 51 - Examples of options to adjust shower detector settings, part of HumiWatch365© system.

3.3 Shower Detector Enabled?

- **YES.** The shower detector is operational and will exhaust moisture outside if the indoor humidity level was equal to or above the setpoint at the time of detection, or will spread moisture in the house if the indoor humidity level was below the setpoint upon detection.

NOTE: Depending on the outside temperature, the quality of your windows and the amount of water vapor in the air, there may be fogging on the windows. This is normal and the fog will disappear as the shower detector exhausts water vapor out of the room.

- **NO.** The detector is not operational.

3.3.1 Sensitivity:

- **NORMAL.** This is the default detection sensitivity in most installations. There will be detection when there is an actual shower running. It may take up to 2 minutes before a shower is detected.
- **HIGH.** The detector is much more sensitive. Use this setting if there are several air returns in your installation having the effect of diluting the amount of moisture to the point where it becomes difficult to detect an actual shower running. Note that a high sensitivity may cause false detections. If so, opt for normal sensitivity.

"HUMIDITY" SETTINGS SCREEN (CONT'D)

			
3.4	This MINOTAIR controls a humidifier? NO	This MINOTAIR controls a humidifier? YES	This MINOTAIR controls a humidifier? YES
3.4.1		Heat Required? NON	Heat Required? NON
3.4.2			By: MINOTAIR

Figure 52 - Examples of options to adjust humidifier settings.

3.4 This MINOTAIR controls a humidifier?

- **YES.** This MINOTAIR controls a humidifier and will call for humidity when needed.
- **NO.** The MINOTAIR does not control any humidifier.

3.4.1 Heat Required?

- **YES.** This humidifier requires an external heat source to humidify the air. The MINOTAIR will start the humidifier when it next calls for heat.
- **NO.** This humidifier generates its own water vapor and can be started without having to wait for a call for heat.

3.4.2 By:

- **MINOTAIR.** The required heat source must be the MINOTAIR. This presumes that the moisture generated by the humidifier is mixed with the MINOTAIR's distribution air.
- **AUXILIARY HEATING.** The required heat source must be the warm air generator (the auxiliary heating unit). This presumes that the humidifier sends humidity in the main return duct of the heat generator.

4. ADJUSTING PROGRAM SETTINGS

Press the **⊙** button for 3 seconds to display the main menu and use the **↑** and **↓** arrows to navigate to the "Program" submenu. Press **↵** to select (Figure 53).



Figure 53 – Main menu – Program settings.

"PROGRAM" SETTINGS SCREEN

There are 4 available options displayed over two screens. Press **↓** or **↑** to move the cursor between options. Once the desired option is selected, press **↵** to change the setting (Figure 54).





Figure 54 - Examples of options to adjust program settings.

4.1 Enabled?

- **NO.** The 7-day program is not enabled. It is not possible to access the subsequent screen, or the temperature setpoints.
- **YES.** The 7-day program is enabled.

4.2 Setpoints:

-  Day temperature.
-  Night temperature.
-  Away temperature.

NOTE: To facilitate the adjustment of the setpoint, pressing **↵** will display two arrows "**↑ ↓**" making it possible to increase or decrease the setpoint using the **↑** and **↓** buttons. After 5 seconds of inactivity or pressing a second time on **↵** disables the arrows.

“PROGRAM” SETTINGS SCREEN (CONT'D)

The daily profile screen enables you to preprogram the MINOTAIR to operate according to a predefined arrangement depending on the day of the week and the time of day.



Figure 55 - Examples of options to adjust daily profile settings.

4.3 “Day” copy to “day”?

- **Current Day profile.** Select the profile to display. Press ↑ to switch from one profile to another. Press ← to select the day to copy the current profile to. Press ↓ to access the details of the current profile.
- **Copy to day.** Press ↑ or ↓ to select the day to which to copy the current profile. Press ← to jump to the copy option.
 - **NO.** The profile is not copied.
 - **YES.** Press ↑ or ↓ to copy the profile. The current profile is copied to the selected day. Press ← to return to the current Day profile.

4.4 Profile details:

- Press ↑ or ↓ to jump from one time slot to the next.
- Press ← to select setpoint for corresponding time slot.
 - ☼ Day.
 - ☀ Night.
 - 🏠 Away.
 - - Not Enabled.
The “Temperature” submenu setpoints are then used.
- Press ↵ to return to Day selection.

5. ADJUSTING FILTER SETTINGS

Press the **⊙** button for 3 seconds to display the main menu and use the **↑** and **↓** arrows to navigate to the “Filters” submenu. Press **←** to select (Figure 56).



Figure 56 – Main menu – Filter settings.

“FILTERS” SETTINGS SCREEN

There are 2 available options displayed over several screens. Press **↓** or **↑** to move the cursor between options. Once the desired option is selected, press **←** to change the setting (Figure 57).

5.1	<pre>Filter Replacement Prefilters: Operation: 00397hrs Reset Counter? NO</pre>	<pre>Filter Replacement Prefilters: Operation: 00457hrs Reset Counter? NO</pre>
5.1.1	<pre>HEPA Filter: NONE Operation: 00000h Reset Counter? NO</pre>	<pre>Thaw Filter? NO HEPA Filter: YES Operation: 00303h Reset Counter? NO</pre>
5.2		

Figure 57 – Examples of options to adjust filter settings.

5.1 Prefilters. The MINOTAIR must be equipped with manufacturer-approved MERV 8 (G4) prefilters to ensure proper functioning. Two prefilters protect the MINOTAIR from dust, which can quickly clog its coils and fan blades. The prefilters must be replaced every three months.

- **Operation.** The number of hours of fan operation since the prefilters were last replaced. This counter is only active when ventilation is running.
- **Reset counter?** Resets the prefilter counter. There needs to be a reset after every change of filters, normally after 3 months of ventilation.

5.1.1 Thaw Filter? At times during the heating season, moisture that comes into contact with the right coil will frost. The formed ice can make the removal of the right filter impossible, the latter being jammed in ice. To remove a jammed filter, it is necessary to defrost the coil. This procedure takes about 3 minutes and will then allow for filter removal without difficulty.

5.2 HEPA Filter. The MINOTAIR is equipped with a High Efficiency MERV 15 (F9) filter, which can eliminate up to 95% of dust and micro-organisms as small as 0.3µm. HEPA filters are recommended for asthma patients. These filters must be replaced every 12 months. Options:

- **YES.** The device is equipped with a HEPA filter.
- **NONE.** The device is not equipped with a HEPA filter.
- **Operation.** The number of hours of fan operation since the HEPA filter was last replaced. This counter is only active when ventilation is running.
- **Reset counter?** Resets the HEPA filter counter. There needs to be a reset after every change of HEPA filter, normally after 12 months of ventilation.

6. OTHER SETTINGS

Press the **Ⓞ** button for 3 seconds to display the main menu and use the **↑** and **↓** arrows to navigate to the “Other Settings” submenu. Press **←** to select (Figure 58).



Figure 58 – Main menu – Other settings.

“OTHER SETTINGS” SCREEN

There are 4 available options displayed over several screens. Press **↓** or **↑** to move the cursor between options. Once the desired option is selected, press **←** to change the setting (Figure 59).

	Other Settings	Other Settings	Autres réglages
	Language: ENGLISH	Language: ENGLISH	Langue: FRANÇAIS
6.1	Backlit Display: AUTO	Backlit Display: ALWAYS	Retroéclairage: AUTO
6.2	Clock: ADJUST	Clock: ADJUST	Horloge: AJUSTER
6.3	Tenant mode: ADJUST	Tenant Mode: ADJUST	Mode locatif: AJUSTER
6.4			

Figure 59 – Examples of options to adjust other settings.

6.1 Language:

- **FRANÇAIS.** The MINOTAIR interface switches to the French language.
- **ENGLISH.** The MINOTAIR interface switches to the English language.

6.2 Backlit display:

- **AUTO.** The digital control screen will light up whenever a button is pressed. The backlight will turn off after 10 minutes of idle time.
- **ALWAYS.** The digital control screen will always stay lit. This option will shorten the life of the neon light used for the backlit display feature. This neon backlight is not covered by the manufacturer's warranty.

6.3 Clock:

- **ADJUST.** Takes you to the screen where you can adjust the time and date of the system clock.

"CLOCK" SCREEN 1

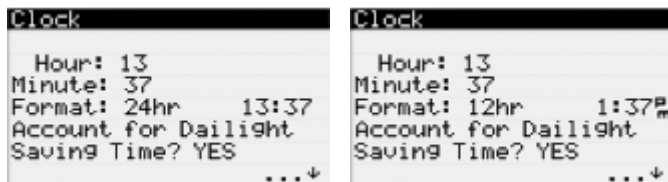

Figure 60 – Examples of options to adjust clock settings 1.

- **Hour:** Adjust the hour between 00 and 23 hours.
- **Minute:** Adjust minutes between 00 and 59 minutes.
- **Format:**
 - **24hr.** Displays the time in 24hr format.
 - **12hr.** Displays the time in 12hr format (AM and PM).
- **Account for daylight saving time?**
 - **YES.** The MINOTAIR will automatically adjust the time at 2 am on the second Sunday of March, and again at 2 am on the first Sunday of November.
 - **NO.** The MINOTAIR will ignore daylight saving time.

"CLOCK" SCREEN 2



Figure 61 - Examples of options to adjust clock settings 2.

- **Day:** Enter the day for today's date.
- **Month:** Enter the month for today's date.
- **Year:** Enter the year for today's date.
- **Format:** Adjust the format for today's date.

6.4 Tenant Mode:

- **ADJUST.** Takes you to the tenant mode settings.

“TENANT MODE” SCREEN



Figure 62 – Examples of options to adjust tenant mode settings.

6.4.1 Tenant Mode

- **NO.** Tenant mode is not activated. End users can access the main menu by pressing the setpoint @ button for 3 seconds.
- **YES.** Tenant mode is activated. End users will need to enter a password to access the main menu after pressing the @ button for 3 seconds. It is also possible to restrict the ability to power on and power off the unit, change temperature and humidity setpoints.

6.4.2 System On/Off

- **NO.** Do not allow end users to turn system On and Off.
- **YES.** Allow end users to turn system On and Off.

6.4.3 Temp. Setpoints.

- **NO.** Do not allow end users to modify the heating and cooling temperature setpoints, mode and units.
- **YES.** Allow end users to modify the heating and cooling temperature setpoints, mode and units.

6.4.4 Humid. Setpoint.

- **NO.** Do not allow end users to modify the relative humidity setpoint.
- **YES.** Allow end users to modify the relative humidity setpoint.

6.4.5 Change Password:

- **SET.** Allows to change the Tenant Mode password.



Figure 63 – Insert new tenant mode password.

7. SYSTEM INFO

Press the **⊙** button to display the main menu and use the **↑** and **↓** arrows to navigate to the "System info" submenu. Press **↵** to select (Figure 64).



Figure 64 – Main menu – System info

"SYSTEM INFO – ODOMETER" SCREEN

On the "System info" screen, press **↓** or **↑** to display various information screens (Figure 51).

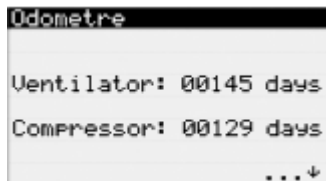

Figure 65 – Examples of information available in the "System info – Odometer" screen.

- **Ventilator:** Number of days the ventilators have been in operation. This counter is incremented only when ventilation is running.
- **Compressor:** Number of days the compressor has been in operation. This counter is incremented only when the compressor is running.

"SYSTEM INFO – SOFTWARE VERSION" SCREEN

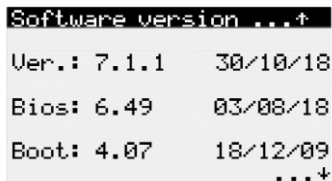

Figure 66 – Examples of information available in the "System info – Software version" screen.

- **Ver.:** Shows the software version of the microcontroller.
- **Bios:** Shows the bios version of the microcontroller.
- **Boot:** Shows the boot version of the microcontroller.

ALARM DESCRIPTIONS

The MINOTAIR is a smart device that can alert you when a situation arises which requires your attention. Its numerous sensors and advanced algorithms do most of the work for you. Furthermore, it speaks to you in a clear language without using complicated codes. This helps you establish a diagnosis, identify possible causes, and, most importantly, decide whether you need to call a technician or not.



When the MINOTAIR alerts you to a situation, the alarm icon “ Δ ” appears and flashes (Figure 67), except in the case of filter replacements – in which case the Δ is replaced with a “change filters” indicator.

NOTE: During an alarm, the MINOTAIR will try to solve the problem by itself. If it succeeds, it will automatically reset the alarm and add it to the log. If it is not successful after a maximum of five attempts, it will display the alarm to bring it to the attention of the owner.



Figure 67 – Alarm button.

Press the Δ button to display the description of the current active alarm. Press Δ once more to reset the active alarm. Reset is only possible if the conditions that triggered the alarm are no longer present.

Alarm	Description	What to do?
	It is time to replace the MINOTAIR's 2 prefilters.	<ol style="list-style-type: none"> 1. Replace the 2 filters with new filters designed for the MINOTAIR. 2. Reset the filter counter by accessing the menu under “5. Filters”, as previously described on page 59.
	It is time to replace the HEPA filter, if applicable.	<ol style="list-style-type: none"> 1. Replace your HEPA filter with a new filter designed for the MINOTAIR. 2. Reset the filter counter by accessing the menu under “5. Filters”, as previously described on page 59.

<p>Alarm</p> <p>No active alarm</p>	<p>There are no alarms currently in effect.</p>	<ol style="list-style-type: none"> 1. No actions need to be taken. 2. Press Δ or \curvearrowright to return to the main screen.
<p>Alarm</p> <p>System overheating. High Pressure Valve. If problem persists, call a technician.</p>	<p>Possible causes:</p> <ul style="list-style-type: none"> • Particularly hot day. • Clogged filters, intake or outlet grilles. • Excess refrigerant. • Defective expansion valve. • Defective or disconnected high-pressure valve. 	<ol style="list-style-type: none"> 1. This is not cause for concern, unless the problem is reported several times within the same day or week. 2. Check filters and outside intake and outlet grilles. Replace or clean if needed. 3. Call a qualified technician if the problem persists.
<p>Alarm</p> <p>Refrigerant leak. Low Pressure Valve or Blown 2A Fuse. Call a technician.</p>	<p>Possible causes:</p> <ul style="list-style-type: none"> • Blown 2A Fuse. • Loose valve. • Defective soldering. • Punctured piping. • Defective or disconnected low pressure valve. 	<ol style="list-style-type: none"> 1. If the fuse is blown, you must find the cause before replacing it. 2. Otherwise, this is a problem which requires the intervention of a qualified technician. 3. Microcontroller will cease all operations, but will keep controlling auxiliary units if applicable. In this case, it remains possible to trigger the auxiliary heating or cooling systems by manually setting the indoor temperature setpoint. Note that the displayed temperature and humidity will be distorted by the fact that the ventilation is stopped.
<p>Alarm</p> <p>System too cold. Low Pressure Valve. If problem persists, call a technician.</p>	<p>Possible causes:</p> <ul style="list-style-type: none"> • Indoor temperature and humidity are too low. • Clogged expansion valve. • Defective or disconnected exhaust fan. • Refrigerant starting to leak. • Defective or disconnected low-pressure valve. 	<ol style="list-style-type: none"> 1. This is not cause for concern, unless the problem is reported several times within the same day or week. 2. Check filters and outside intake and outlet grilles. Replace or clean if needed. 3. In the case of a clogged expansion valve, the system should repair itself. 4. Call a qualified technician if the problem persists.

<p>Alarm</p> <p>Clock Board Fault, or Dead Battery!</p> <p>Call a technician.</p>	<p>Possible causes:</p> <ul style="list-style-type: none"> • Defective internal clock. • Clock battery is dead. • Defective controller. 	<ol style="list-style-type: none"> 1. This is a problem which requires the intervention of a qualified technician. 2. Do not try to change the battery yourself, because you risk irreversibly damaging the microcontroller. 3. Batteries should have a life span of about 5 to 10 years.
<p>Alarm</p> <p>Permanent Memory Fault</p> <p>Call a technician.</p>	<p>Possible cause:</p> <ul style="list-style-type: none"> • Defective memory. • Defective controller. 	<ol style="list-style-type: none"> 1. This is a problem which requires the intervention of a qualified technician.
<p>Alarm</p> <p>Exterior Temperature, Sensor B1 defective or disconnected!</p> <p>Call a technician.</p>	<p>Problem with the outside temperature sensor.</p> <p>Possible cause:</p> <ul style="list-style-type: none"> • Defective or disconnected B1 sensor. • Defective controller. 	<ol style="list-style-type: none"> 1. This is a problem which requires the intervention of a qualified technician. 2. The microcontroller will default to a -40°C (-40°F) outside temperature setting to force recirculation mode.
<p>Alarm</p> <p>Conditioned Temp. Sensor B2 defective or disconnected!</p> <p>Call a technician.</p>	<p>Problem with the conditioned temperature sensor.</p> <p>Possible cause:</p> <ul style="list-style-type: none"> • Defective or disconnected B2 sensor. • Defective controller. 	<ol style="list-style-type: none"> 1. This is a problem which requires the intervention of a qualified technician.
<p>Alarm</p> <p>Defrost Temperature, Sensor B3 defective or disconnected!</p> <p>Call a technician.</p>	<p>Problem with the defrost temperature sensor.</p> <p>Possible cause:</p> <ul style="list-style-type: none"> • Defective or disconnected B3 sensor. • Defective controller. 	<ol style="list-style-type: none"> 1. This is a problem which requires the intervention of a qualified technician. 2. The microcontroller will default to a -15°C (5°F) to force a defrost cycle at regular intervals, in order to avoid freezing in the evaporator.
<p>Alarm</p> <p>Indoor Temperature, Sensor B4 defective or disconnected!</p> <p>Call a technician.</p>	<p>Problem with the indoor temperature sensor.</p> <p>Possible cause:</p> <ul style="list-style-type: none"> • Defective or disconnected B4 sensor. • Defective controller. 	<ol style="list-style-type: none"> 1. This is a problem which requires the intervention of a qualified technician. 2. The microcontroller will default to a 21°C (70°F) indoor temperature. 3. Manually set indoor temperature setpoint according to your current heating and cooling needs.
<p>Alarm</p> <p>Indoor Humidity, Sensor B6 defective or disconnected!</p> <p>Call a technician.</p>	<p>Problem with the indoor humidity sensor.</p> <p>Possible cause:</p> <ul style="list-style-type: none"> • Defective or disconnected B6 sensor. • Defective controller. 	<ol style="list-style-type: none"> 1. This is a problem which requires the intervention of a qualified technician. 2. The microcontroller will default to a 40% indoor humidity. 3. Manually set indoor humidity setpoint according to your current indoor humidity level needs.

<p>Alarm</p> <p>Fan A Stoppage.</p> <p>Cut power to unit for 60 seconds. If problem persists, call a technician.</p> <p>Alarm</p> <p>Fan B Stoppage.</p> <p>Cut power to unit for 60 seconds. If problem persists, call a technician.</p>	<p>Possible causes:</p> <ul style="list-style-type: none"> • Fan start-up failure due to poor quality of electricity. • Defective or disconnected ID1 sensor. • Defective or disconnected fan. • Defective controller. 	<ol style="list-style-type: none"> 1. This is not cause for concern, unless the problem is reported several times in a row 2. The microcontroller will cease all operations, but will keep controlling auxiliary units if applicable. In this case, it remains possible to trigger the auxiliary heating or cooling systems by manually setting the indoor temperature setpoint. Note that the displayed temperature and humidity will be distorted by the fact that the ventilation is stopped. 3. Call a qualified technician if the problem persists.
<p>Alarm</p> <p>Too much air restriction!</p> <p>Verify filters and outside air intake.</p>	<p>Possible causes:</p> <ul style="list-style-type: none"> • Dirty filters. • Outside intake grille clogged. • Dirty coils. • Implosion of flexible ducts due to negative static pressure. • Obstructed ventilation ducts or improperly installed. • Ventilation duct diameters are too small. • Supply or return grilles closed or clogged. 	<ol style="list-style-type: none"> 1. Check filters and outside intake and outlet grilles. Replace or clean if needed. 2. Microcontroller will cease all operations, but will keep controlling auxiliary units if applicable. In this case, it remains possible to trigger the auxiliary heating or cooling systems by manually setting the indoor temperature setpoint. Note that the displayed temperature and humidity will be distorted by the fact that the ventilation is stopped. 3. Call a qualified technician if the problem persists.
<p>Alarm</p> <p>Fan A - B</p> <p>Fans are reversely connected.</p> <p>Call a technician.</p>	<p>Possible cause:</p> <ul style="list-style-type: none"> • Fans A and B are swapped. 	<ol style="list-style-type: none"> 1. This is a problem which requires the intervention of a qualified technician. 2. Terminal Y3 controls Fan A (left) while terminal Y4 controls Fan B (right).

MAINTENANCE

The MINOTAIR is a powerful device, but it requires a certain amount of maintenance on a regular basis. Regular maintenance of this device will ensure optimal and worry-free working conditions. Furthermore, failure to perform this maintenance will render the device's warranty null and void. Please do not neglect the maintenance of your MINOTAIR.

Frequency	What to do?
Monthly	<ul style="list-style-type: none">• Inspect the air intake and outlet grilles located outside and remove any clogging if necessary (leaves, dust, snow, etc.).• Inspect the condensate drain and clean if needed.
Every 3 months	<ul style="list-style-type: none">• Replace filters with filters designed for the MINOTAIR
Every 12 months	<ul style="list-style-type: none">• Change HEPA filter, if applicable• Clean humidifier according to the manufacturer's guidelines, if applicable.• Replace the filter cartridge on the humidifier's water line, if applicable.
When needed, at least every 12 months	<ul style="list-style-type: none">• Disinfect the condensate pan. To do so:<ol style="list-style-type: none">1. Shut off power from the MINOTAIR by closing the circuit breaker or the circuit switch.2. Using a vice grip, squeeze the flexible condensate pipe at its lowest point to prevent dripping into the floor drain. Do not squeeze too strongly, as it could damage the pipe wall.3. Access the motorized damper (Figure 3). <i>You can take this opportunity to vacuum the interior by being careful not to damage the wires and sensors.</i>4. Remove the orange plug located on the motorized damper compartment floor ("R" component in Figure 2).5. Prepare 4 liters (1 gal) of bleach solution diluted in three parts cold water (1 liter bleach in 3 liters water = 4 liters). WARNING: Use gloves and wear goggles to handle this solution. Bleach can irritate the skin and discolor clothes.6. Carefully pour the bleach solution into the motorized damper compartment. The solution will pour into the hole where you pulled the plug earlier. NOTE: Aluminum tarnishes when in contact with bleach. This will not affect the operation and durability of the device in any way.7. Leave the solution in the condensate pan for approximately 20 minutes.8. Remove the vice grip and carefully pour 4 liters (1 gal) of additional cold water into the motorized damper compartment.9. Put back the plug on the motorized damper compartment floor.10. Close the Main Access Panel and restart the unit.

LIMITED WARRANTY

Dedicated to offering the highest quality products, MINOTAIR Ventilation Inc., the “Manufacturer”, is pleased to offer a 5-year limited warranty on parts. The “Warranty” applies to the CATU-V12 and PentaCare V-12 Compact Air Treatment Unit, the “Product”.

- This Warranty only applies if the Product was purchased in Canada or the United States. If the Product was purchased elsewhere, please contact the authorized reseller in the country where it was purchased.
- The Manufacturer guarantees that all mechanical, electric and electronic components of the product are free from defects in material and workmanship, under normal use and maintenance. This Warranty is valid for 5 years, starting from the date of the original purchase.
- If the Product becomes defective during the period of this Warranty, provided this defect is not excluded from the Warranty, the Manufacturer will repair or replace, at its discretion, the Product using new or refurbished parts. In cases where the manufacturer decides to replace the Product, this Warranty will continue to apply to the replacement Product for the residual duration of the original Warranty.
- Warranty claims, other than those described above, are expressly excluded.

IMPORTANT: We ask that you carefully store your original proof of purchase, because without it the Warranty will be null and void. In the improbable case where you have to make a claim under this Warranty, we will need you to produce your original proof of purchase which we will return to you after the claim has been validated.

LIMITATIONS AND EXCLUSIONS

- This Warranty does not cover consumable items such as filters, fuses, batteries, etc.
- This Warranty does not cover third-party equipment such as humidifiers, condensate pumps, heating coil, etc. Refer to the manufacturers of these devices to learn more about their respective warranties.
- This Warranty does not cover cosmetic damages that do not affect the products’ functioning. This includes, without limitation: scratches, bumps, stains, backlight intensity, metal tarnish or discolor, etc.

IMPORTANT: While our products are tested and inspected in our factory before they are shipped, it is your responsibility to visually inspect the Product for defects upon delivery and to advise us of any defect within 24 hours.

- Any damages or defects resulting from improper handling, wrongful installation or use, or an act of God (fire, tornado, earthquake, flooding, etc.) are excluded from this Warranty.
- All modifications or repairs made by unauthorized personnel (including the user) will automatically void the Warranty.
- This Warranty does not cover handling, shipping and labor fees.
- No other person (distributor, reseller, vendor, etc.) is authorized to promise a Warranty on the Manufacturer’s part.

DAMAGE CLAIMS

The Manufacturer will not be liable towards the buyer for any loss or damage caused directly or indirectly and of any nature whatsoever. In no case will the Manufacturer’s responsibility be greater than the Product’s invoiced price or MSRP, whichever is less.

OTHER WARRANTY RIGHTS

This Warranty does not limit the buyer’s legal rights in any way as a consumer.

NOTES: