

## Board of Trustees

### Plainfield Public Libraries

**December 10, 2012; 7:00pm – Philip Read Memorial Library**

**Approved**

Attending: Anita Brown, Kara Toms, Mark Pensgen, Nancy Liston, Hillary Sundell, Nancy Norwalk (Director, Philip Read Memorial Library), Mary King (Director, Meriden Library)

Members of the public: Rod Wendt, Dennis Girouard

- A. Call to order – 7:24pm
- B. Agenda approved
- C. No public Comments
- D. Status Report on ADA Study Committee (Rod Wendt/Nancy Liston)
  1. Met on November 29 for first mtg.
  2. ADA Study Committee members met with Jillian Shedd, who is Accessibility Specialist, on December 10. Initial comment is that the Town only needs one facility to be accessible by law, to go forward is because we want to. Cost goal posts= cost on basics, need to get the community involved. Jillian will verify above comment and report back on other questions brought up at meeting.
  3. There was some discussion on meeting in a private home.
- E. Approval of minutes of previous meetings
  1. November 5, 2012 Minutes  
MOTION – It was moved and seconded that the minutes be received and approved as submitted. The motion was unanimous and carried.
  2. November 7, 2012 Minutes  
MOTION – It was moved and seconded that the minutes be received and approved as submitted. The motion was unanimous, Nancy Liston abstained and carried.
  3. November 15, 2012 Minutes  
Total dollar amount to be changed – MOTION – It was moved and seconded that the minutes as amended be received and approved as submitted. The motion was unanimous and carried.

F. Donations

1. Nancy N. received a check for a 2013 grant and will wait to deposit in January.

G. Non-public session announcement requested by Mary King, ML Director – RSA 91-A:3 II (b): The hiring of any person as a public employee.

H. Monthly Reports: Receive reports and take any action required

1. Philip Read Memorial Library
  - a. David Grobe estimate for work. See attachment.
2. Meriden Library Director
  - a. Door locks being worked on – odd size door creating problems. Knox box quote - \$250. Perhaps to ask Town to provide funds? Basement Door not latching properly. Mary King to ask Gatekeeper for estimate.

MOTION – It was moved and seconded to approve knox box for ML and have Kara follow up with Town to have monies come out of Library Town Repair Fund (outside work). The motion was unanimous and carried.

MOTION – It was moved and seconded to approve Grobe's estimate for PRML and Kara to follow-up with Town to have monies come out of Library Town Repair Fund (outside work). The motion was unanimous and carried.

MOTION – It was moved and seconded that the reports be accepted. The motion was unanimous and carried.

3. Treasurer's Report

- a. Discussion on low gallon oil usage at Meriden Library.

MOTION – It was moved and seconded that the report be accepted. The motion was unanimous and carried.

I. Action Items

1. Library Aide Position description

MOTION – It was moved and seconded to approve as submitted. The motion was unanimous and carried.

2. Dates and Times for next year's meetings. Anita to e-mail schedule to trustees and Directors.

3. Trustee elections for 2013 – Anita running again, Kara not running, Nancy L. will if no one else qualified is found.
4. Policies
  - a. Meeting Room Policy deferred to next meeting.

J. Budget

1. See Letter from Steve Hallerin
2. Agreed to purchase goods this year to offset budget next year.

MOTION – Hillary moved and Nancy L. seconded asking for a total appropriation from the town of \$113,818.00 for the budget. The motion was unanimous and carried.

K. 10:35pm - Go into non-public session per RSA 91-A:3 II(b)

MOTION It was moved and seconded to go into non-public session per RSA 91-A:3 II(b). The vote was as follows: Anita-Yes, Kara-Yes, Mark-Yes, Nancy L.-Yes, Hillary-Yes. The motion was unanimous and carried.

MOTION – It was moved and seconded to return from non-public session per RSA 91-A:3 II. The motion was unanimous and carried.

Discussion centered subsequent retirement of one employee and the hire of a new Aide to replace employee, salaries were discussed.

MOTION – It was moved and seconded to not seal the non-public minutes.

The Vote was as follows: Anita – Yes, Kara – Yes, Mark – Yes, Nancy L. –Yes, Hillary – Yes. The Motion was unanimous and carried.

Library specific meetings:

January 14, 2013; Meriden Library; Plainfield Elementary School; 7PM  
January 16, 2013; PRML; 7pm

Next Regular Meeting:

February 11, 2013; PES; 7pm

Adjournment at 11:15pm

Attachments; Philip Read Memorial Library Directors Reports

Estimate from Center of Town Company

Meriden Library Directors Reports

Press Release for Going Live!

Treasurer's Report

# Meriden Library 2010 - 2012

## Visits

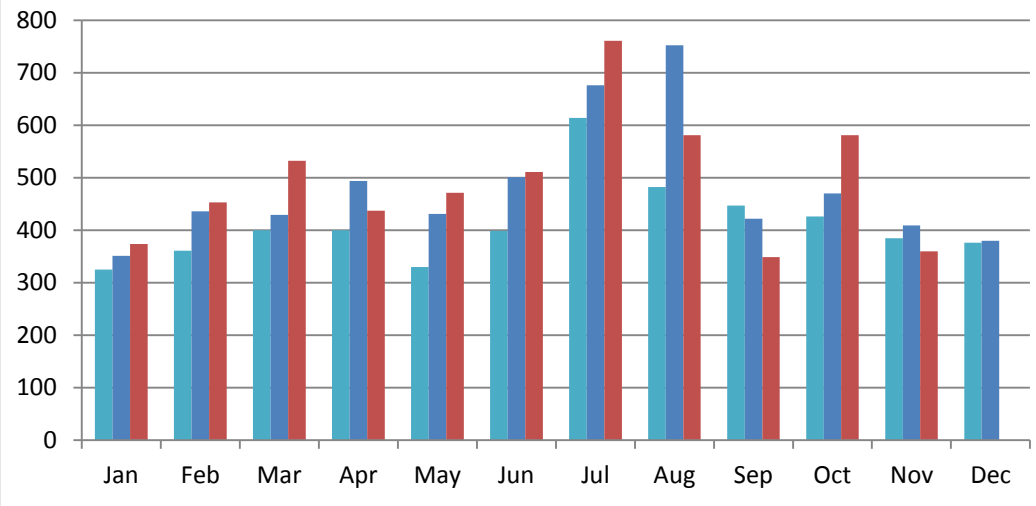

## Circulation

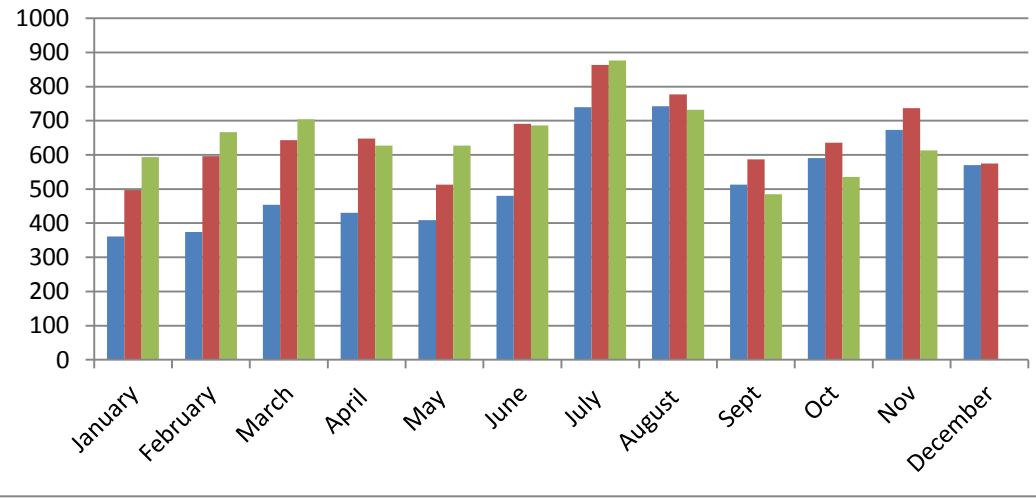

**DIRECTOR'S REPORT**  
**PHILIP READ MEMORIAL LIBRARY**  
**December 2012**  
**Activities and Statistics for November 2012**

1. Programming: Henry Homeyer read from his new junior book. Illustrator Josh Younger was also present and read from his new book. November was quieter, after a very busy October. Upcoming: Story Time and Photos with Santa; author reading with Sarah Taylor; Mother Goose story hour; 2 movies.
  
2. Bequest: I am pleased to announce that the Friends of the Library have received a bequest of \$1,000 from Bea Clark, designated to the Building Fund.
  
3. Automation: Our volunteers are moving really fast on this project, averaging 20-25 books an hour. There is a new volunteer who will come in for training after Christmas. The mystery section is finished. The remaining supplies needed (card sleeves and patron barcodes) just arrived. I will be having a staff meeting/training session shortly and begin handing out the new cards.
  
4. I have been notified that the Tasker Bridge Fund is awarding the library a grant of \$600. The check will not come until January
  
5. Maintenance: I am having ongoing discussions with Joanna Sharf about replacing the fixture top of the pole lamp on the front walk and adding another pole light to provide additional lighting in the front. I have also had another electrician look at it, but haven't received a quote yet. Joanna did drill some drain holes in the fixture and this may solve the water problem there.  
The annual elevator and fire alarm tests have been completed. Bills will be coming and we may have to encumber for them as we did last year, as they sometimes don't come until January.  
I have the quote from David Grobe for the new outside work he identified.
  
6. Firemen's visit: I had invited both the Plainfield and Meriden Fire Departments to come for an orientation/instructional visit as they have so many new members. Thirteen firemen attended. We had a really good tour/visit with lots of questions. I showed them, among other things, how to shut off the alarms, how to rescue someone from the elevator, as well as a complete tour.
  
7. Pictures from Ruth Hendrick: Alice's daughter has sent us a new larger copy (on canvas) of the photo collage of Alice which we have kept in the children's room. She also sent a signed print of a Bev Doolittle painting for the Friends to sell.

## Philip Read Memorial Library 2012 Patron Visits

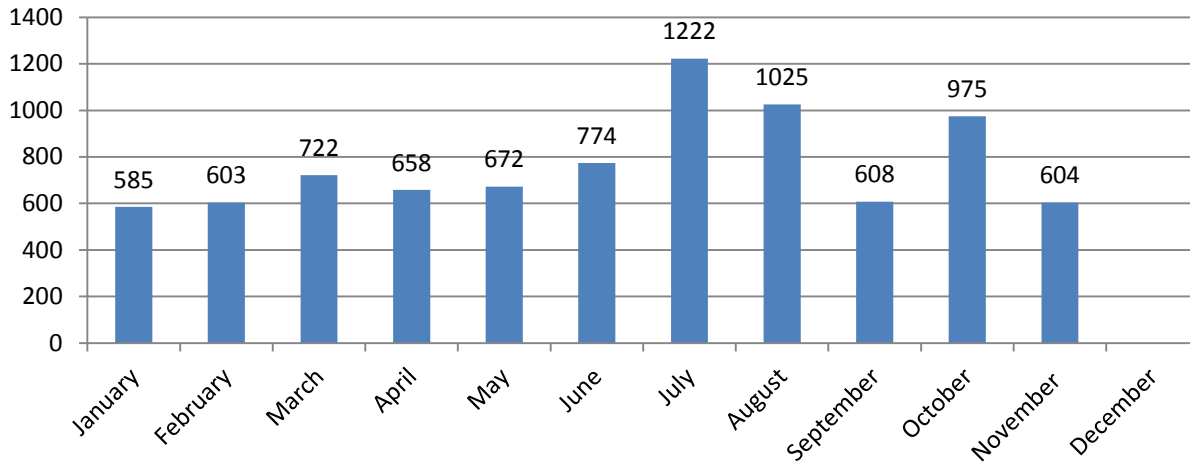

## Philip Read Memorial Library 2012 Circulation

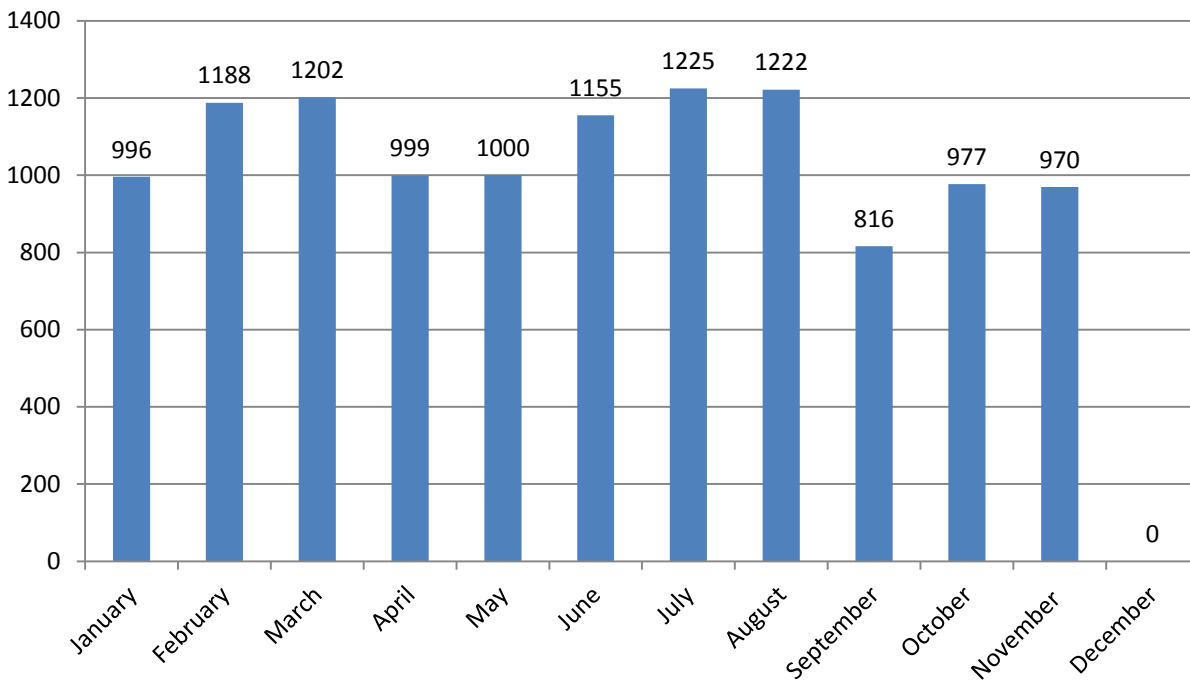

**Meriden Library**  
**Profit & Loss Budget vs. Actual**  
 January 1 through December 7, 2012

	Jan 1 - Dec 7, 12	Budget	\$ Over Budget	% of Budget
<b>Ordinary Income/Expense</b>				
<b>Income</b>				
Town Appropriation	38,759.67	42,376.00	-3,616.33	91.5%
Town Approp - FICA	1,889.20	2,112.00	-222.80	89.5%
Trust Funds	850.00	850.00	0.00	100.0%
Gifts	2,355.56	50.00	2,305.56	4,711.1%
Book Fines/Copier	145.00	100.00	45.00	145.0%
Book Sales	30.00	0.00	30.00	100.0%
<b>Interest Income</b>				
Interest - Savings	33.30	10.00	23.30	333.0%
Interest Checking	1.99	0.00	1.99	100.0%
<b>Total Interest Income</b>	35.29	10.00	25.29	352.9%
Misc Income	186.00	300.00	-114.00	62.0%
<b>Total Income</b>	44,250.72	45,798.00	-1,547.28	96.6%
<b>Expense</b>				
Salaries	24,734.67	27,611.00	-2,876.33	89.6%
FICA	1,889.20	2,112.00	-222.80	89.5%
Sick Pay	0.00	285.00	-285.00	0.0%
<b>Library Materials</b>				
Audio/Visual	1,162.90	500.00	662.90	232.6%
Books & magazines	3,800.41	5,000.00	-1,199.59	76.0%
<b>Total Library Materials</b>	4,963.31	5,500.00	-536.69	90.2%
Telephone	473.25	540.00	-66.75	87.6%
Electricity	1,014.77	1,000.00	14.77	101.5%
Fuel	2,187.51	3,200.00	-1,012.49	68.4%
Water/Sewer	400.00	500.00	-100.00	80.0%
Supplies	602.44	800.00	-197.56	75.3%
Postage	170.61	300.00	-129.39	56.9%
Professional Activities	298.23	450.00	-151.77	66.3%
Programs	1,066.08	400.00	666.08	266.5%
Furniture/Equipment	0.00	100.00	-100.00	0.0%
Maintenance	1,547.50	1,400.00	147.50	110.5%
Automation	199.25	1,000.00	-800.75	19.9%
Computer	477.95	500.00	-22.05	95.6%
Misc Expense	40.46	100.00	-59.54	40.5%
<b>Total Expense</b>	40,065.23	45,798.00	-5,732.77	87.5%
<b>Net Ordinary Income</b>	4,185.49	0.00	4,185.49	100.0%
<b>Other Income/Expense</b>				
Other Expense				
Building Capital Improvements	4,600.00	0.00	4,600.00	100.0%
<b>Total Other Expense</b>	4,600.00	0.00	4,600.00	100.0%
<b>Net Other Income</b>	-4,600.00	0.00	-4,600.00	100.0%
<b>Net Income</b>	<b>-414.51</b>	<b>0.00</b>	<b>-414.51</b>	<b>100.0%</b>



Meriden Library  
Director's Report  
November 2012

November Statistics Attached  
Closed November 12—Veteran's Day  
Closed November 22---Thanksgiving Day

### **Programs**

We held a children's after school craft program on Thursday, November 17. This was the first time that we held an afternoon program and felt that it was successful with 4 Adults and 18 Children attending.

### **Meetings**

On November 14 and 17 I trained at the Howe Library circulation desk to learn the circulation functions of Evergreen. I also met with Pam Smith on November 28 to do a last review of our catalog and loan details before the go-live date of December 6.

I attended the Librarians of the Upper Valley Coop's annual meeting on November 17. This meeting is the business meeting for the group so there was no program. There was an interesting discussion of the possibility of an "Upper Valley" library card that would give patrons borrowing privileges at libraries throughout the Upper Valley. It was decided that the discussion would be continued at a future meeting.

I attended the first meeting of the Meriden Library ADA Study Group on Thursday, November 29. I will continue to attend the meetings as scheduling allows.

### **Automation**

Work continues to catalog all of our holdings. I think that the current rate of adding items will continue until we have all of our materials added.

I have configured our current desk space to allow for the equipment we will need for automation; a bar code scanner and a receipt printer.

\*\*\* Items added and patrons added report to come.

### **Building**

Gatekeeper Lock and Safe came to the library on Thursday, November 15 to replace the passage locks on two doors and to re-key deadbolts. The locks that they brought would not work in the doors so the work has not been completed. Both exterior doors are 2 ¼" thick and it is difficult to find locks that will work in them. They are currently working with suppliers to find a lock that will fit.

**Philip Read Memorial Library  
Treasurer's Report  
January 1 through December 7, 2012**

	Jan 1 - Dec 7, 12	Budget	\$ Over Budget	% of Budget
<b>Income</b>				
Encumbered Funds 2011	2,404.38	3,194.05	-789.67	75.3%
Town Appropriation				
Appropriation-Operations	28,675.00	30,330.00	-1,655.00	94.5%
Appropriation-Salary	30,748.07	33,749.00	-3,000.93	91.1%
FICA	2,352.16	2,582.00	-229.84	91.1%
Town Appropriation - Other	0.00	0.00	0.00	0.0%
Total Town Appropriation	61,775.23	66,661.00	-4,885.77	92.7%
Trust Fund Income	2,400.00	2,400.00	0.00	100.0%
Fines	572.22	100.00	472.22	572.2%
Gifts				
Building Fund Transfer	32,436.07	0.00	32,436.07	100.0%
Gifts - Other	160.00	50.00	110.00	320.0%
Total Gifts	32,596.07	50.00	32,546.07	65,192.1%
Grants	1,550.00	700.00	850.00	221.4%
Misc Income	62.47	300.00	-237.53	20.8%
Total Income	101,360.37	73,405.05	27,955.32	138.1%
Cost of Goods Sold				
Cost of Goods Sold	0.00	0.00	0.00	0.0%
Total COGS	0.00	0.00	0.00	0.0%
<b>Gross Profit</b>	101,360.37	73,405.05	27,955.32	138.1%
<b>Expense</b>				
Building Fund Expense	32,436.08	0.00	32,436.08	100.0%
Encumbered Funds	0.00	3,194.05	-3,194.05	0.0%
Payroll				
Salaries	30,748.07	34,749.00	-4,000.93	88.5%
FICA	2,352.16	2,624.00	-271.84	89.6%
Payroll - Other	0.00	0.00	0.00	0.0%
Total Payroll	33,100.23	37,373.00	-4,272.77	88.6%
Library Materials				
Books and Magazines				
Materials from Fine account	899.00	0.00	899.00	100.0%
Books and Magazines - Other	6,402.07	8,000.00	-1,597.93	80.0%
Total Books and Magazines	7,301.07	8,000.00	-698.93	91.3%
Audio Visual Materials	1,226.91	1,200.00	26.91	102.2%
Library Materials - Other	0.00	0.00	0.00	0.0%
Total Library Materials	8,527.98	9,200.00	-672.02	92.7%
Catalog Services/Automation				
Automation Expense from Grants	1,578.73	0.00	1,578.73	100.0%
Catalog Services/Automation - Other	949.46	1,500.00	-550.54	63.3%
Total Catalog Services/Automation	2,528.19	1,500.00	1,028.19	168.5%
Supplies	1,003.95	1,500.00	-496.05	66.9%
Postage	184.23	250.00	-65.77	73.7%
Programs				
Programs-Grants	355.00	0.00	355.00	100.0%
Programs - Other	428.24	600.00	-171.76	71.4%
Total Programs	783.24	600.00	183.24	130.5%
Professional Activities	386.15	450.00	-63.85	85.8%
Oil	4,597.23	7,500.00	-2,902.77	61.3%
Electricity	2,465.68	3,400.00	-934.32	72.5%
Telephone	1,077.77	1,080.00	-2.23	99.8%
Water	194.90	300.00	-105.10	65.0%
Maintenance				
Maintenance-General Expenses	2,363.44	3,000.00	-636.56	78.8%
Elevator	1,362.12	1,700.00	-337.88	80.1%
Maintenance - Other	830.17	0.00	830.17	100.0%
Total Maintenance	4,555.73	4,700.00	-144.27	96.9%
Furnishings and Equipment	295.07	500.00	-204.93	59.0%
Computer Hardware and Software	591.98	1,000.00	-408.02	59.2%
Miscellaneous Expense				
Grants	0.00	700.00	-700.00	0.0%
Miscellaneous Expense - Other	10.00	200.00	-190.00	5.0%
Total Miscellaneous Expense	10.00	900.00	-890.00	1.1%
<b>Total Expense</b>	92,738.41	73,447.05	19,291.36	126.3%
<b>Net Income</b>	<b>8,621.96</b>	<b>-42.00</b>	<b>8,663.96</b>	<b>-20,528.5%</b>

## Meriden Library Stats

### Visits

	January	February	March	April	May	June	July	August	Sept	Oct	Nov	December	Total
<b>Patron Visits</b>													
Adults	316	348	434	316	374	348	429	349	291	458	266		3929
Young Adults	6	8	14	15	17	31	58	37	4	14	6		210
Children	52	97	84	106	80	132	274	195	54	109	88		1271
<b>Total</b>	<b>374</b>	<b>453</b>	<b>532</b>	<b>437</b>	<b>471</b>	<b>511</b>	<b>761</b>	<b>581</b>	<b>349</b>	<b>581</b>	<b>360</b>	<b>0</b>	<b>5410</b>

### Circulation

	January	February	March	April	May	June	July	August	Sept	October	November	December	Total
<b>Adults</b>													
Fiction	185	144	181	171	154	160	208	143	149	157	133		1785
Non-Fiction	45	48	66	49	51	29	33	34	32	48	37		472
<b>Children</b>													
Fiction	204	238	244	196	242	304	398	301	158	186	223		2694
Non-Fiction	37	66	59	55	33	44	65	59	38	25	100		581
DVD	63	88	68	66	63	58	81	59	52	44	54		696
Magazine	22	20	13	12	25	18	22	28	10	21	25		216
ILL incoming	15	38	43	62	32	32	23	78	33	38	15		409
Audio	22	25	30	16	27	41	46	30	13	16	26		292
<b>Total</b>	<b>593</b>	<b>667</b>	<b>704</b>	<b>627</b>	<b>627</b>	<b>686</b>	<b>876</b>	<b>732</b>	<b>485</b>	<b>535</b>	<b>613</b>		<b>7145</b>
Volunteer Hours		5.5	9.5	10	30	24	24	20.5	26	22	21		192.5
New Patrons													

### Programs

	January	February	March	April	May	June	July	August	Sept	October	November	December	Total
<b>Story Time/Play Group</b>	4	2	2	2	1	4	3	5	4	4	4		35
Child	9	4	5	5	5	34	29	52	14	20	13		190
Adult	7	2	3	4	3	10	9	35	10	10	11		104
<b>Book Groups</b>	2	1	2	1	2	1	1	1	1	2	1		
Tuesday	6	6	7	8	9	8	7	4	8	8	4		75
M/D	10		8		10					12			40
<b>Special Programs</b>		2	1	1		1	2	1		2	1		11
Children		13	11	10			35	8		26	18		121
Young Adult							2						2
Adult		5	42	6		2	26	10		66	4		161
<b>Genealogy</b>	3	1	2		2	2				5			15
<b>Fiber Art</b>	5	2											7
<b>Total Attendance</b>	<b>40</b>	<b>31</b>	<b>78</b>	<b>33</b>	<b>29</b>	<b>56</b>	<b>108</b>	<b>109</b>	<b>32</b>	<b>147</b>	<b>51</b>		<b>714</b>
<b>Total Programs</b>	<b>8</b>	<b>7</b>	<b>6</b>	<b>5</b>		<b>7</b>	<b>6</b>	<b>7</b>	<b>5</b>	<b>8</b>	<b>6</b>		<b>65</b>

BOARD OF TRUSTEES  
PLAINFIELD TOWN LIBRARIES  
BUDGET MEETING

November 15, 2012; 6:45pm – Philip Read Memorial Library

Approved Minutes

Attending: Anita Brown, Kara Toms, Mark Pensgen, Nancy Liston, Hillary Sundell, Mary King (Director, Meriden Library), Nancy Norwalk (Director, Philip Read Memorial Library).

Members of the Public; Dennis Girouard

- A. Call to Order – 7:00pm
- B. Public Comments – None
- C. Budget discussion
  - a. Mark showed on big screen the changes from 2012 to 2013, and what the systems total will be that we will present to the town.
  - b. Extra lines have been added for additional items not in the original budget expenses, i.e. separate for Trustees; seminars and supplies for secretary. Keeping in mind that we need to streamline to have one spreadsheet for both libraries.
  - c. Discussion on Automation Maintenance fees for both libraries. Need to add \$800.00 additional for annual maintenance & fees
    - 1. Discussion on needs for additional equipment needed for automation; how many computers, stands and other items. Possibilities on donated computers, the need for monitors to go with existing towers. We should purchase a computer before the end of the year; Mark to see how much is left. We should encumber \$500.00 for next year towards this goal.
  - d. Discussion on fuel consumption, electric and other normal operating costs. New contracts with Irving for oil for both libraries. New heat pump at ML should show savings.
  - e. Discussion on wish lists, new copier vs. repair, basement furniture, new admin hours for both libraries
  - f. Discussed *Friends* responsibilities
  - g. Salary increases 2% vs. 1.7% discussed. Mark ran both sets of numbers.

MOTION – Moved and seconded to vote on Preliminary 2013 Budget, for a total appropriation from the town of \$116,818.

VOTE

Anita Brown – Yes

Kara Toms – No, wants the salary increase to be 2%

Mark Pensgen – Yes

Nancy Liston – Yes

Hillary Sundell – Yes

MOTION carried and Mark will send out copies and submit the preliminary budget to the town.

Next meeting: December 10, 2012, 7:15pm - PRML

Adjourn 9:45pm

hs

**Board of Trustees**  
**Plainfield Public Libraries**  
**Philip Read Memorial Library featured**  
**November 7, 2012; 7:00pm; Philip Read Memorial Library**

**Approved**

Attending: Anita Brown, Kara Toms, Mark Pensgen, Hillary Sundell, Nancy Norwalk (PRML Director)

Absent: Nancy Liston

Members of the Public: Dennis Girouard

- A. Call to order & Roll Call; 7:10pm
  - 1. Agenda approved
  - 2. October 1, 2012 minutes approved, no changes from Nancy N.
- B. Correspondence – None
- C. No Public Comments
- D. No Non-public meeting announcement
- E. Finance Report
  - a. Mark sent out most current data, including payroll info from Michelle at Town offices.
  - b. Any outstanding bills for construction have been paid. Nothing outstanding, need to clean up towards end of year for budget discussions. Need to spend public monies first. Nancy mentioned recorded Grant money. Mark & Nancy N. discussed adding in new matching areas for Grants – in & out. versus Programming lines.  
We need to make sure that we have construction lines in and out as well. Nancy N. wanted to make sure that the encyclopedia is in correct line. Nancy N. suggested meeting with Mark to adjust line item titles to make sure that no overspending might occur because of wrong delineation of cost. i.e. Flag applied to supplies. No problem with reallocating budget lines.  
Question on whether we are doing ok on oil, Hillary will contact Irving to find out about \$150 rebate on signing up for each library. Both libraries on automatic delivery with Irving.  
MOTION: Kara moves to accept Treasurer's report, Anita seconded. The vote was unanimous and carried.
- F. Director's Report
  - 1. Attendance was recorded on the Statistic sheet, Anita asked to have attendance for each program recorded on main report.
  - 2. Facebook – Teagan Atwater has setup the Facebook account for PRML – Discussion on who should administrate the page, Kara will assist Nancy N. on updating Facebook page. The new website looks great. Kara still found links that are in error on the Town website on Monday. Hillary to suggest to Mike S. about Diane/Suellen on Town website still.

3. Automation – Volunteers getting faster. More hours also being put in. Anita asked if it is possible to have experienced volunteer automation book imputers to track how many books per hour. Nancy N. said it was possible, but it would be an average, many things pending. Rough average would be fine.
- Hillary asked if Nancy N. comfortable with progress on automation; Nancy N. said volunteers have to be scheduled, only 2 computers are tasked to the program at the moment. Question on downloading onto more computers was discussed previously. Mark asked if we want to purchase a new computer. Discussion on computer needs – i.e. catalog computer, dumb computers, and where to put station. Need for a moveable cart. Mark suggests a need for a meeting on computer needs and what to budget for next year. Nancy N. asked if we have spent all the Tasker Covered Bridge Funds that was to be used specifically for automation. Mark will look into it and get back to the BOT. He also mentioned that he had purchased a printer for ML for the automation, and that we need to remember to put that in the budget for next year for PRML.
- Dennis; How much room does the software require? What about donating old computers? Mark said all that the computer has to do is “browse”. Nancy & Mark to speak with Des Hudson so that we have some standards on computers. Kara mentioned that we should have a technology plan to go forward. Hillary asked if we can go ahead and schedule a day, Anita suggested that we go ahead and get the cart.
- Kara asked about new books coming in, are they being automated, because of the impact on Meriden. Nancy reiterated that there is no time to do this when library is open, too busy, and doesn't feel that that it would impact ML because the patrons can see what both libraries have. Hillary brought up the discussion from Monday night's meeting, on Mary's concerns for when ML goes Live, that when the system goes live that what will be seen is all the New books that she has put in and that the demand will be overwhelming. Nancy N. suggested that one of the PRML volunteers could do new books instead of the sections that they are currently working on. All agreed that this would be good. Mark asked how many books in New Book section? Maybe 50 – 100 books. More discussion about difficulty in finding books in Howe library system. Nancy N. has inquiry into Mary White at Howe about this. Meriden Library going live in December, Nancy N. feels that there is plenty of time to get those New Books imputed by then. Hillary asked what days Nancy N. usually came in for administrative time. Hillary to look into scheduling a volunteer kick start afterhour's day at the library.

MOTION: Anita moved to approve and Mark seconded. The vote was unanimous and carried.

#### G. Facilities Report

1. Issues on Fire Alarm. The alarm was not included in the egress phase. We have a Fire Alarm expert. The original blueprints didn't have the fire egress, therefore no alarm, so now we need one for new egress. Nancy has called for a new Building Committee to discuss this and possible future items. Anita said that it will be less than \$2,000. Mark also pointed out that we need to list other budget items for the basement.

November 15, 2012; 6:45pm Trustee Budget Meeting for both libraries confirmed.

#### F. Budget 2013 preliminary discussion

1. Professional Activities –Nancy N. concerned about big conferences every other year; some years are good, some not.
2. 2 Computers (1) circulation desk, (1) Dumb, catalog and what is needed for automation, chit printer, podium style table. Plastic envelopes to come out of supplies. “Go Live” fee. Mark’s understanding is that it is prorated to coincide with Howe’s schedule. Nancy will look up amount of these fees.
3. Downloadable books fee is also going up next year – shared with ML. Software license fees, and Movie license fee (\$100) staying the same.
4. Maintenance – Nancy N. would like another lamp post on walkway. – Nancy to speak with Johanna for estimate on this as well as fixing other light at front. Nancy is also trying to communicate with the Energy Audit person as to Old lights in Parrish room, they need replacing. Nancy N. will attempt this coming week to contact person from PSNH to quote on Interior lights. She also has Grant info on upgrade of lights.
5. Outdoor Bench for wireless people. Nancy N. has priced out several varieties, so far anywhere \$300 - \$500. and were very flimsy and could be picked up and walked away with. Anita asked if these numbers included setup for the bench.
6. Nancy N. has asked for a quote for air conditioning for PRML, still waiting.
7. Generator for use as a shelter – Rob Taylor’s original idea.
8. Need more hours to be open and more Admin. Hours. Anita asked what Nancy N. was looking for. Nancy N. mentioned that we could open Thursday, for 6 – 8 hrs. Nancy N. to provide breakdown of hours for Nov. 15 meeting. Has anyone spoken with the Town Offices as to raises? Mark said he had not yet. Mark has structured the spreadsheet so that pending on how much a raise would be, it would automatically flow through the numbers.
9. Nancy will set-up AV equipment for Thursday, Nov. 15 meeting.
10. Mark feels that most of these items are doable, however, big items such as Air Conditioning and generator might fall under private donations, might be a stretch to ask Townspeople to fund those.
11. To ask Johanna to give an estimate on generator, discussion on Adirondack chairs instead of bench. Anita will pursue where Dartmouth gets their benches. Nancy N. will ask Mark Overman about benches.
12. Does anyone want to have a discussion with the Town about generators? Kara said she would speak to Steve.
13. Dennis mentioned that we might want to check into schedule of these fluorescent tubes being outdated. Still a box of tubes downstairs.
14. Hillary wanted to make sure that we have an article in PlainFacts stating our position about the Meriden Library monies, what we have discovered up to this point, and the disposition of those monies, to be more transparent to the Town. Not everyone reads the Minutes that are posted. Discussion on the dedication of a circulation desk using those monies. This would be a recommendation to the Town. Request to Nancy for a reminder on Deadline for PlainFacts. Dennis asked if we were planning on writing a warrant article, yes, that was the idea after



communicating with the Town. Mark thought that meeting with Paul Franklin to find out procedure would be a good place to start. The next item to be done is to restate the last 2 – 3 years of financial accounts. Terry Knowles had said that we should do this, but not how. So hoping that Paul Franklin can guide us in this.

Hillary to provide Nancy L with bullet points for PlainFacts.

Next Regular Meeting Date: December 10, 2012; Philip Read Memorial Library; 7:15pm

MOTION to adjourn made by Kara, seconded by Mark. The vote was unanimous and carried.

Adjournment: 8:45pm

Attachments: Director's reports (3)

hs

**DIRECTOR'S REPORT**  
**PHILIP READ MEMORIAL LIBRARY**  
**November 2012**  
**Activities and Statistics for October 2012**

1. Programming: October was extremely busy. Programs held: VINS program with live birds, Poe mystery theater, felting classes, Civil Air Patrol program, regular book discussion and Saturday card games. Upcoming: Henry Homeyer will read from his new junior book.
2. Web Page: Mike Sutherland has launched the new web page. We are still working together to add more information. Facebook: Teagan Atwater has set up a Facebook page for us.
3. Automation: Evergreen has upgraded the program. This has caused some issues (with both libraries). We weren't able to completely add information on each item. Therefore, we suspended work until the issues were solved. Per an e-mail just received this weekend, we should be able to add the info now, although the issues aren't completely fixed.
4. NH State System: The state library computer system was been down for over a week now—mostly due to the state government network problems (before the hurricane). We are having to do interlibrary loans through e-mail. This has also impacted catalog searching.
5. Maintenance: The slate roof expert has finished his annual inspection of town buildings and found no issues with the library roof. Emily's Electric has replaced the outside outlet that was not working and done some temporary work on the front pole light. I am having ongoing discussions with her about replacing the fixture and adding another pole light to provide additional lighting in the front.

## Philip Read Memorial Library 2012 Patron Visits

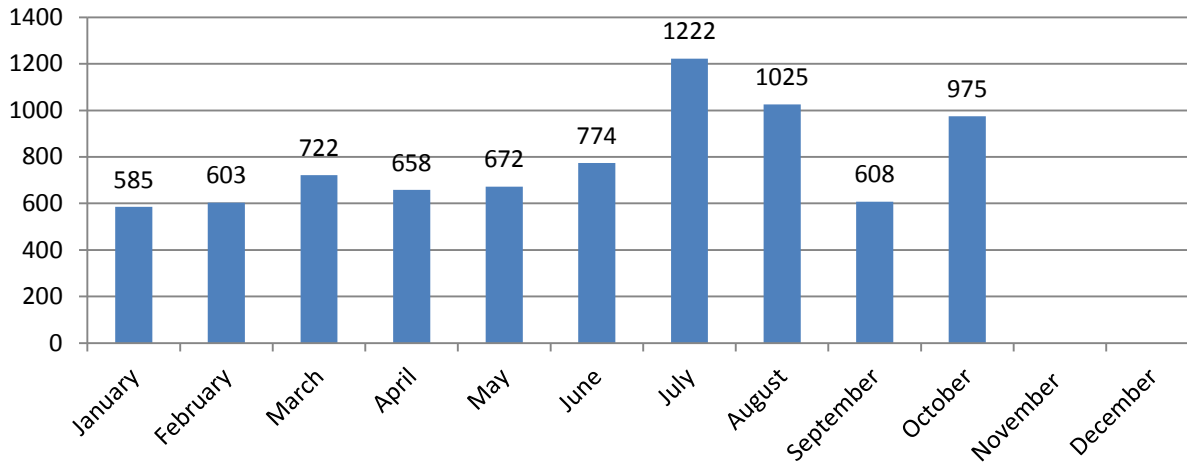

## Philip Read Memorial Library 2012 Circulation

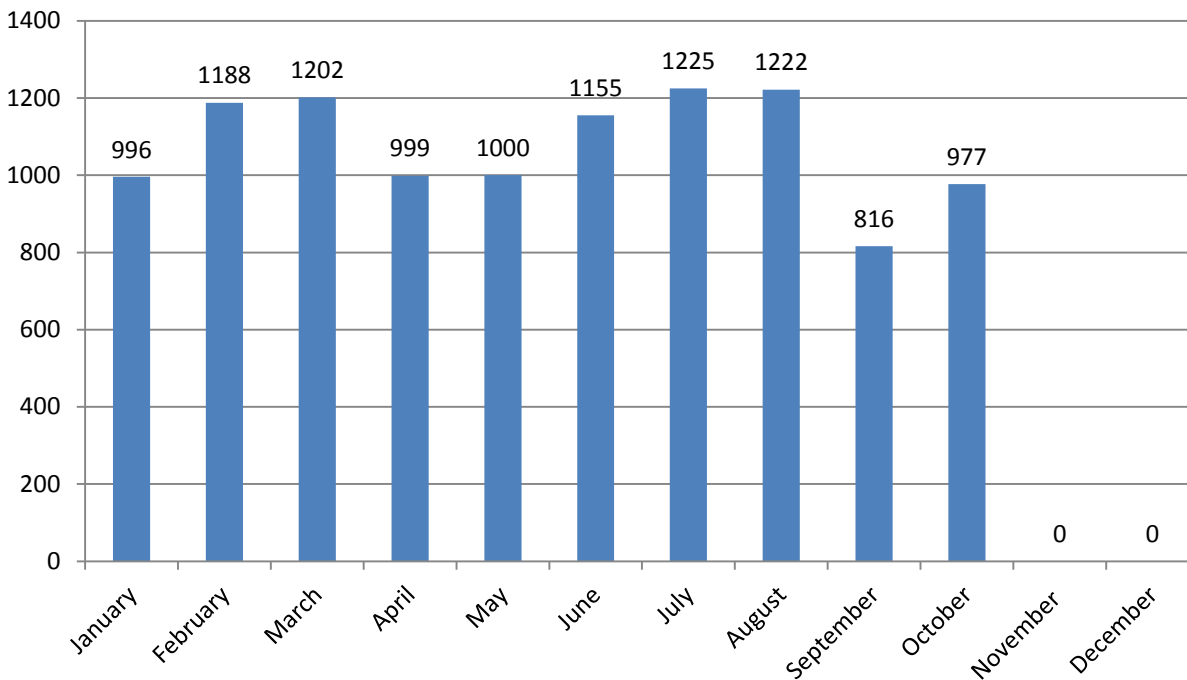

**Board of Trustees  
Plainfield Public Libraries  
Meriden Library featured**

November 5, 2012; 7:15pm; Plainfield Elementary School

**Approved Minutes**

Attending: Anita Brown, Kara Toms, Mark Pensgen, Hillary Sundell, Nancy Liston, Mary King (ML Director)

Members of the Public: Rod Wendt

A. Call to order & Roll Call; 7:20pm

1. Approval of changed Agenda.
2. Minutes of October 1, 2012 meeting were approved with changes - C. change to lower case T in timing and M in money, G. change Nancy N. to Anita for finding out about Lawyer's fee. MOTION: to approve as amended by Kara and seconded by Anita. Mark abstained due to absence on October 1 meeting. The vote was unanimous and carried.

B. Correspondence

1. Letter from Selectboard received to be read later in meeting, Mary mentioned notice in e-mail from Steve Halleran about ADA committee.

C. Public Comment

1. Rod Wendt said he was here to speak on ADA committee. MOTION: to rearrange agenda to assist guest Rod Wendt. Move agenda up item 3.c. ADA Compliance Study Committee. Hillary moved and Kara seconded, The vote was unanimous and carried.
2. Copy of letter from Selectboard read by Anita. One resident declined being on the ADA Committee, so at this point we have name members; Ron Bailey, Bob Kline, Susan Gaty as possible members. Discussion on need for Ex Officio to be named. Nancy L. offered to undertake that responsibility. Rod Wendt took the floor and spoke of how he foresaw the forward path of the named committee;

- Law requirements
- Need to look at Resources – Legal – Expertise – Cost
- Trustees would be welcome at all meetings
- Possible meeting place would be Judy Hallam's

Anita to put ADA Compliance Study Committee at top of future agendas. Rod W. envisions experts looking at both facilities. Nancy L. stressed the importance of "Library Architects" as a better way to go. Mary mentioned also that the Committee be aware of Mary's commitment and of using her as a resource. Anita suggested that Mary go to the first meeting and that the committee knows who she is, and that she will make herself available. Discussion on setup of meetings for "ADA Compliance Study Committee" (ADACSC) should be noted on website and have regular meetings – remember 48 hour notice and to post at 2 public places.

Mark reminded everyone that our goal was to have our facilities be “Universally available to all patrons” – discussion as to whether it should read “accessible” – Nancy L. questioned as whether it should be “Services” or “Facilities”. Rod W. felt that the Charge was consistent with what the policies & philosophies of the BOT are, he asked if we had a Mission Statement, answer “Yes” one for both libraries. Rod W. noted that he would like to have at least two meetings before Christmas. Kara posed that we should make a decision on another resident and to suggest Nancy L. as Ex Officio, Anita will forward this request to Steve Halleran. Everyone in agreement? All concurred. Rod Wendt left the meeting at this point.

D. Announcement of Non-Public Session RSA 91-A:3 II(b) The hiring of any person as a public employee.

E. Reports for ML

1. Mary began with a video point demo program to show everyone what the online catalog would look like and how it would behave. This will show both libraries. Questions on possible date for going live. Nancy L. wanted to know if interlibrary loans possible with this program? Mary replied that yes, but not at this point. Mary suggested drafting a letter to Valley News to say thanks to Mary White and Pam at Howe Library.

NOTE: When we pick a day, to remember to let Kim know!

Mary said there were changes on the Director’s report which she will send to Hillary.

Kara had questions on New Patrons. Mary said all patrons are new at this point, because they are all getting new cards.

Nancy L. asked if the 3301 books (now in Evergreen) represented about ½ of the books in collection. Answer – Approximately, Yes.

Discussion on Lock issue. Mary handed around a proposal from Gatekeeper for a new lock system for the doors at ML.

NOTE: Revisit lockbox outside in future for Meriden Library

Kara will contact Selectboard for funds for funding of Gatekeeper’s lock system.

Nancy L moved and Anita seconded, the vote was unanimous and carried.

2. Budget

a. Printer for Evergreen system not on current budget.

3. Specific Items

a. Policies to be discussed at joint meeting in December.

Mark discussed the budget thus far; mention of meetings already held with Mary & Nancy N. and Hillary.

b. Mary handed out a design by Mark Overman of a circulation desk. She is waiting on a bid later this week. Mary has done research in various areas and feels that most of the prefab layouts are inferior and will not last, and are very expensive. Mark Overman built the desk at PRML. Much discussion on circulation desk, Possible private monies to fund the desk, or the other thought was to put forth a warrant article to the Selectboard and Town to use the monies that are being returned to the Town i.e. Terry Knowles’s decision and Mark’s fact-finding to be used towards the circulation desk built in honor of Betty Ann.

- c. Mary has written for a grant for a computer station for patrons. Cost approx. \$1,300.
- d. Nancy L. asked if we should budget for databases and would that be beneficial. Discussion on current databases; Epscohost, Ancestry.com (paid for each year by a patron), looked at Grolier's, but the Elementary School already has, no need to duplicate. Mark suggested budgeting "Workspaces"
- e. Anita asked about Professional Development Budgeting, Mark said that a budget of \$800. per library for a basic 3 day with expenses, also possible leapfrogging each other year per library, discussion on Aide training, maybe a conference.
- f. Kara would like to see Programming monies go up, \$400 a year too low, (Mary did mention that there were private monies also added to that total.) Would also like to see "furniture" and other line items be more equal between libraries. Mark mentioned that PRML was a busier library and had more hours and more fuel costs. That PRML needs to use more resources more wisely. Mark suggested that there be more sharing between libraries. Kara added to that note that we should create the dynamic that when we purchase one book it belongs to ALL not just one library. How to do sharing without the natural barriers, need help from Trustees, perhaps to use the acquisitions fairly. Mark mentioned concerns about when going live with ML, what does that mean to the PRML? Mary felt that she would get hit hard because ML has been putting all "New acquisitions in right away, and PRML has not, so, the only "New Books" are at ML at this point. Which could create an issue.
- g. Discussion on Budget meetings – November 15, 2012 at PES at 7pm – Kara to see if available.

Discussion on recommendation to Selectboard for return of monies to Town. Possible dedication of New Circulation Desk to Betty Ann. Mark pointed out that the money that was disputed is free from private monies as was approved by Terry Knowles letter. We just need to make recommendation to the Town. Hillary mentioned that we should get the explanation out to the public, using PlainFacts or the Website, so as to be more transparent to the Townspeople. The minutes are "public" but not easily readable. Mark stated that if people were really concerned why aren't they here at the meetings or contacting the Trustees, other than Dennis. We stood up in front of the Selectboard with anyone willing to listen and explained the process that we have gone through and the answer from Terry Knowles. Kara mentioned that she thought it was a good idea to put it out there so that no one is surprised when we make the recommendation. Hillary affirmed that it would be a good thing to show that we are not hiding anything.

Anita said that what we have been trying to do is to keep a monthly report in PlainFacts. We can also mention that there is a copy of the letter from Terry Knowles in the minutes posted on the website if anyone would like

to see it. We did miss this month, but will make sure that with everyone's help get it in following months to come.

Mark stated that there were a couple of items that we still need to finish up with this issue; 1. We need to reissue 2 to 3 years of past financial reports. So that anyone, who wishes to know, can do so. This will be completed in due time.

Mark will forward the budget upcoming worksheets to all of us.

h. Nancy L. has concerns with her Liaison job with Mike Sutherland, Our IT guy for the Town. Question was asked if Diane's name was still on the Website, Hillary affirmed that it was still on the Town Website; Mark brought up the website and found that this was true. Mike to be notified of this, and hopefully replace Diane's name with Suellen's.

E. MOTION: To go into Non-Public Session RSA 91-A:3 II(b) *The hiring of any person as a public employee*. Requested by Mary King, Director of Meriden Library. Anita moved and Kara seconded.

10:16pm

Roll Call Vote:

Anita Brown	Yes
Kara Toms	Yes
Mark Pensgen	Yes
Hillary Sundell	Yes
Nancy Liston	Yes

MOTION: was unanimous and carried.

MOTION – Anita moved and it was seconded to return to public session per RSA 91-A:3 II.

Roll Call Vote:

Anita Brown	Yes
Kara Toms	Yes
Mark Pensgen	Yes
Hillary Sundell	Yes
Nancy Liston	Yes

MOTION was unanimous and carried.

MOTION – It was moved by Mark to seal the minutes from the non-public session per RSA 91-A:3 II and seconded by Anita.

Roll Call Vote;

Anita Brown	Yes
Kara Toms	Yes
Mark Pensgen	Yes
Hillary Sundell	Yes
Nancy Liston	Yes

MOTION was unanimous and carried.

Next Regular Meeting Date: December 10, 2012; Philip Read Memorial Library; 7:15pm

MOTION to adjourn made and seconded

Adjourn: 10:30pm

Attachments: Meriden Director's reports (3)

(1) Amended

Treasurer's Report

Skyline Designs Drawing of possible circulation Desk

hs



Next Regular Meeting Date: December 10, 2012; Philip Read Memorial Library; 7:15pm

MOTION to adjourn made and seconded

Adjourn: 10:30pm

Attachments: Meriden Director's reports (3)

(1) Amended

Treasurer's Report

Skyline Designs Drawing of possible circulation Desk

hs

# Meriden Library 2010 - 2012

## Visits

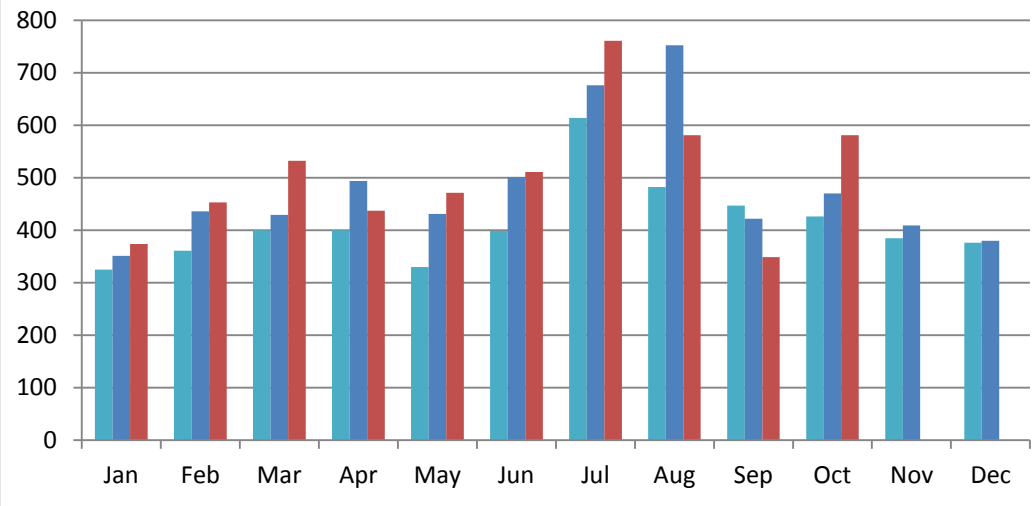

## Circulation

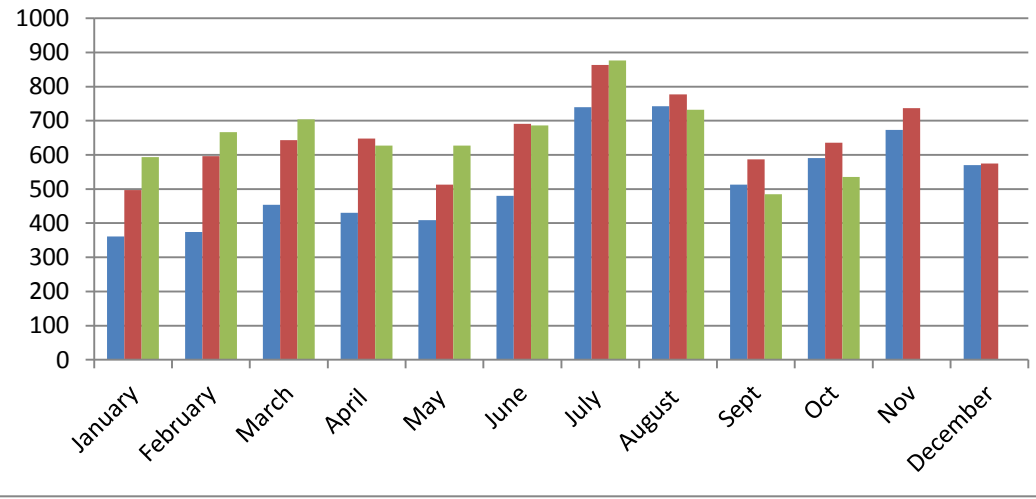

Meriden Library  
Director's Report  
October 2012

October Statistics Attached  
Closed October 8—Colombus Day  
Closed October 20—Unplanned Lock-Out

**Programs**

On Wednesday, October 9 the Meriden Library held a New Hampshire Humanities Council sponsored program, New Hampshire's One Room Rural Schools: The Romance and the Reality. The program was held at the Aidron Duckworth Museum with the Friends of the Meriden Library hosting a reception before the event. Meriden's Steve Taylor was the presenter. 50 people attended the presentation.

Our Genealogy Club hosted a special presenter on Monday, October 15. The club had been on recess for the summer months so to kick off a new year Jane Belcher, an experienced and published genealogist, lead the group. Several new patrons joined the group and we hope that they will continue as members.

We held our annual Halloween Craft Night on Tuesday, October 23. Families were invited to stop by the library between 5-7pm to have a snack, decorate pumpkins, and create a Halloween decoration. Each child received a pumpkin. I am grateful to Rachel Stoddard for donating pumpkins from her garden. 18 adults and 26 children attended the event.

**Meetings/Conferences**

On Tuesday, October 2 staff members (Mary White, Director, Pam Smith, Technical Services Librarian and Peter Appleton, Reference Librarian) from the Howe Library visited the Meriden Library. Once a year Howe staff members use staff meeting time to visit another library. Not only were they able to see our library but we spent time talking about how small, rural libraries are run with minimal staff.

I met with officers of the Meriden Library Association on Tuesday, October 9. This served as the annual meeting for the group. There was discussion of what function this organization will have now that there will be a separate Friends group. The MLA is addressing any compliance issues that may arise.

Lori Estey and I attended the New Hampshire Library Association's **READS** (Reference and Adult Services) fall conference, Not Your Grandma's Library: Interlibrary Loans, Technology, and Intellectual Freedom, on Friday, October 26 in Plymouth.

**Automation**

I continue to weed materials from the collection. This month I focused on Adult Fiction. That area is nearly complete for weeding and being cataloged into Evergreen.

Between 9/30-10/19 we added 374 items to the Evergreen catalog for a total of 3301. I have three volunteers actively adding items. I have been tracking the time spent in relation to the number of books added and find that an average of 20-25 books can be added per hour. Because of an upgrade to the Evergreen software on October 24 we

lost a week of cataloging time. Instead volunteers removed materials from the NH State catalog. We remain on track to go live in early December.

As of 10/19/12

<b>Owning Library</b>	<b>Description</b>	<b>Items Added</b>
Meriden Library	CD Audio	
	book	146
	DVD	180
	Book	2975
		3301

As part of the space plan for the upper stairs adult section and work space I rearranged some shelving and furniture. I also submitted a grant to the Tasker Covered Bridges Fund for funds to purchase a computer workstation and office furniture.

On Saturday, October 20 our new passage lock on the front door malfunctioned and we could not get into the building. Because we were locked out we learned that there are no keys to the side entry and the keys that are kept at the town office are not current. I called Gatekeeper Lock and Safe on Monday to help us get into the library. The only way into the building was through a window. We will need to address the issues with all of the entry locks currently on the building.

## Meriden Library Stats

### Visits

	January	February	March	April	May	June	July	August	Sept	Oct	Nov	December	Total
<b>Patron Visits</b>													
Adults	316	348	434	316	374	348	429	349	291	458			3663
Young Adults	6	8	14	15	17	31	58	37	4	14			204
Children	52	97	84	106	80	132	274	195	54	109			1183
<b>Total</b>	<b>374</b>	<b>453</b>	<b>532</b>	<b>437</b>	<b>471</b>	<b>511</b>	<b>761</b>	<b>581</b>	<b>349</b>	<b>581</b>	<b>0</b>	<b>0</b>	<b>5050</b>

### Circulation

	January	February	March	April	May	June	July	August	Sept	October	November	December	Total
<b>Adults</b>													
Fiction	185	144	181	171	154	160	208	143	149	157			1652
Non-Fiction	45	48	66	49	51	29	33	34	32	48			435
<b>Children</b>													
Fiction	204	238	244	196	242	304	398	301	158	186			2471
Non-Fiction	37	66	59	55	33	44	65	59	38	25			481
DVD	63	88	68	66	63	58	81	59	52	44			642
Magazine	22	20	13	12	25	18	22	28	10	21			191
ILL incoming	15	38	43	62	32	32	23	78	33	38			394
Audio	22	25	30	16	27	41	46	30	13	16			266
<b>Total</b>	<b>593</b>	<b>667</b>	<b>704</b>	<b>627</b>	<b>627</b>	<b>686</b>	<b>876</b>	<b>732</b>	<b>485</b>	<b>535</b>			<b>6532</b>
Volunteer Hours		5.5	9.5	10	30	24	24	20.5	26	22			171.5
New Patrons													

### Programs

	January	February	March	April	May	June	July	August	Sept	October	November	December	Total
<b>Story Time/Play Group</b>	4	2	2	2	1	4	3	5	4	4			31
Child	9	4	5	5	5	34	29	52	14	20			177
Adult	7	2	3	4	3	10	9	35	10	10			93
<b>Book Groups</b>	2	1	2	1	2	1	1	1	1	2			
Tuesday	6	6	7	8	9	8	7	4	8	8			71
M/D	10		8		10					12			40
<b>Special Programs</b>		2	1	1		1	2	1		2			10
Children		13	11	10			35	8		26			103
Young Adult							2						2
Adult		5	42	6		2	26	10		66			157
<b>Genealogy</b>	3	1	2		2	2				5			15
<b>Fiber Art</b>	5	2											7
Total Attendance	40	31	78	33	29	56	108	109	32	147			663
Total Programs	8	7	6	5		7	6	7	5	8			59

Skyline Designs Drw #103012-01 7' x 9' E11 Desk  
Scale:  $\frac{1}{4}$ "=1'

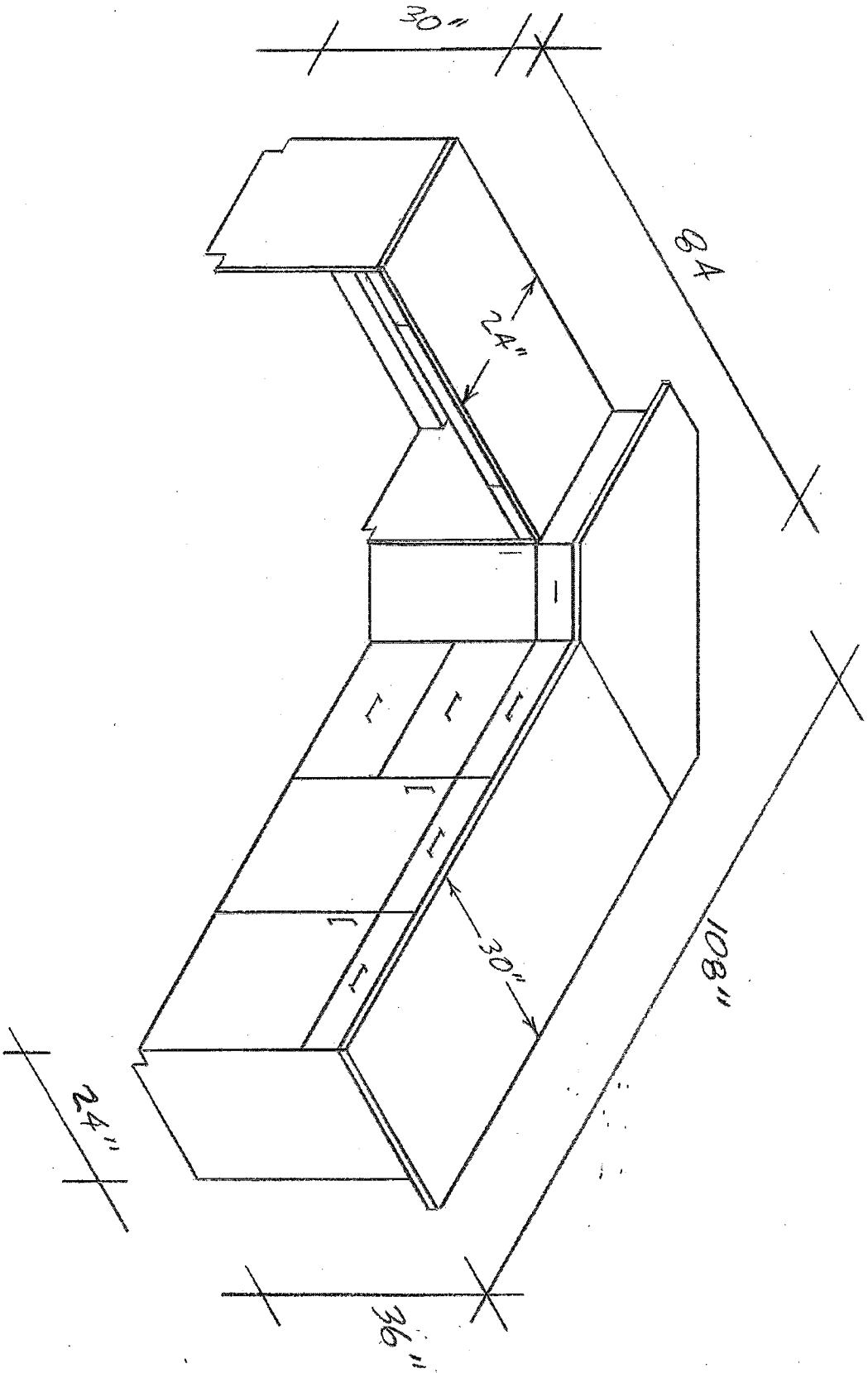

**Board of Trustees**  
**Plainfield Public Libraries**  
**October 1, 2012; 7:15pm; Plainfield Elementary School**  
**Approved Minutes**

Attending: Anita Brown, Kara Toms, Hillary Sundell, Nancy Liston, Nancy Norwalk (PRML Director), Mary King (ML Director)

Absent: Mark Pensgen

Members of the Public: Rod Wendt, Steve Beaupre

A. Call to Order 7:15pm

1. Public Comments: None
2. Minutes of September 17, 2012 meeting were accepted with changes that last initials be added for the two Nancy's. MOTION: to approve as amended by Anita and seconded by Kara. Sealed Minutes of September 10, 2012 were approved except for Mark's vote (not present).
3. Donations: MOTION: to accept donation of PRML Friend's group for \$3,740 for basement egress by Kara, Hillary seconded, the vote was unanimous and carried. Mary discussed the Vera Chellis donations, from last month \$800. And this month an additional \$400. Bringing it up to date as of September 27, 2012. MOTION: to accept donation of \$400. By Kara, Hillary seconded. The vote was unanimous and carried.
4. Correspondence: Anita read letter received from Terry Knowles stating that the amount that was presented to the AG's office was accepted as clear of any private monies. (attachment)  
NOTE: BOT needs to file recommendation to the Town by January; Town needs copy of T. Knowles letter.
5. There will be no Non-Public Session tonight.

B. Director's Reports for PRML & ML

1. ML – Discussion on program that Mary attended on Friend's group. Question from Nancy L. on clarification of Trustee/Liaison relationship with Friend's group. Answer is you can help, but can't belong to a "Friend's Group" as a Trustee.

Mary has moved furniture in the library to make it more accommodating for patrons, when a meeting is in progress. Discussion on the need for more volunteers and the level of competency for various jobs. Discussion on interlibrary loan statistics. Needs in the future for volunteer transport of books, possible liability issues. Any information on these issues to be forwarded to BOT to keep on file for future reference.

MOTION: to approve ML Director's report by Hillary, Kara seconded. The vote was unanimous and carried. (attachments)

2. PRML – Discussion on report. Good attendance on programs for September; Lorax, Cellar hole and others. Will be having programs every Saturday; Vins, Poe mystery and more. Anita asked if we could have #'s of participants for each program in the monthly report (both libraries). Nancy N. discussed website

renovation by Mike Sutherland. Kara asked about photo agreements i.e. the website photos. Discussion on patron numbers between the two libraries. Hillary asked about eventually getting these sorts of statistics from Evergreen. Answer, yes.

Discussion on weeding, statistics are on reports, books are not actually counted until “out the door”. Nancy N. is starting process of issuing new patron cards, possibly ordering plastic sleeves. Mary mentioned that she had plenty and could lend Nancy N. enough to get started. Further discussion on automation, interchangeable patron numbers between libraries.

MOTION: to approve PRML Director’s report by Kara, seconded by Nancy L. The vote was unanimous and carried.

C. Finalize Charge to committee for ADA compliance for Meriden Library:

1. Hillary read draft charge from September 17 meeting. Much discussion on wording and on bullet points. Kara asked for advice from Steve B. and Ron Wendt. Nancy L. uncomfortable with asking before actual committee named.

2. Ron Wendt offered a written proposal for the wording of the charge.

Discussion on being specific on the charge and timing. It was suggested that the trustees get educated in what ADA means exactly and develop contacts and people of skills, and define how much money needed for the process.

MOTION: Anita read “Charge”, changes adopted. Anita moved to accept, Hillary seconded. The vote was unanimous and carried. Hillary to type up tonight and forward to Board.

D. Volunteer luncheon: Discussion on “Reception”. November 3<sup>rd</sup> at 1pm was decided on, location still to be determined.

Nancy N. & Mary to forward names of volunteers to Hillary. Kara to forward flyer to Hillary.

E. Budget Items; meetings to be announced, once Mark is back in town.

F. Job description:

1. Discussion on verbiage for physical abilities. Verbiage was pulled directly from the Directors Job description, recommendation to make changes in director’s reports as well. No crawling and no squatting.

Nancy N. to send final on Job description to Hillary. Amend #4 on Director’s report.

MOTION: to accept Job description as amended by Kara, Nancy L. seconded. The vote was unanimous and carried.

G. Policies:

1. Nancy L. to meet with Mary and Nancy N. about Collection Policy.

2. Nancy L. and Hillary to do Reference Policy.

3. Information from Bernardina about lawyers’ cost and going to Friend’s to see about covering cost. Anita to find out amount required for Lawyer’s fee (?)

NOTE: Kara to call and schedule upcoming meetings with the school office.

MOTION to adjourn made by Kara, seconded by Anita. The vote was unanimous and carried.



Adjourn: 9:55pm

Attachments; Letter from Terry Knowles  
ML Director's report (3)  
PRML Director's report (3)  
Charge as amended  
Job Description (not amended)

Library Specific Meeting: November 5, 2012; PES; 7:15pm

Library Specific Meeting; November 7, 2012; Philip Read Memorial Library; 7:00pm

Charge to the Plainfield Selectboard from the Plainfield Public Library Trustees;

“To establish a committee from the Township of Plainfield to examine the need for ADA compliant facilities & services at the Meriden Library with the following time goals:

1) A definition of the task and the timeline for completing the study by February 1, 2013.

2) Identification by February 1, 2013 of funds needed to complete the study.

3) Presentation of realistic alternatives with pros and cons and associated costs to be completed by December 31, 2013.”

Meriden Library  
Director's Report  
September 2012

September Statistics Attached

On Wednesday, September 12, I and several trustees attended a meeting with Terri Knowles, Assistant Director of Charitable Trusts, to review analysis of funds from prior years.

I attended the Librarians of the Upper Valley Coop meeting in Bradford, VT on Monday, September 17. The program was focused on Friends groups.

I devoted my time in September to weeding and organization of the library. I have been able to complete the weeding of several library sections to prepare for cataloging.

From 9/4-9/30, 547 items were added to the catalog.

The Meriden Library report of items cataloged in Evergreen as of 9/30/12:

Owning Library	Description	Items Added
Meriden Library	CD Audio book	147
	DVD	178
	Book	2602
		2927

# Meriden Library 2010 - 2012

## Visits

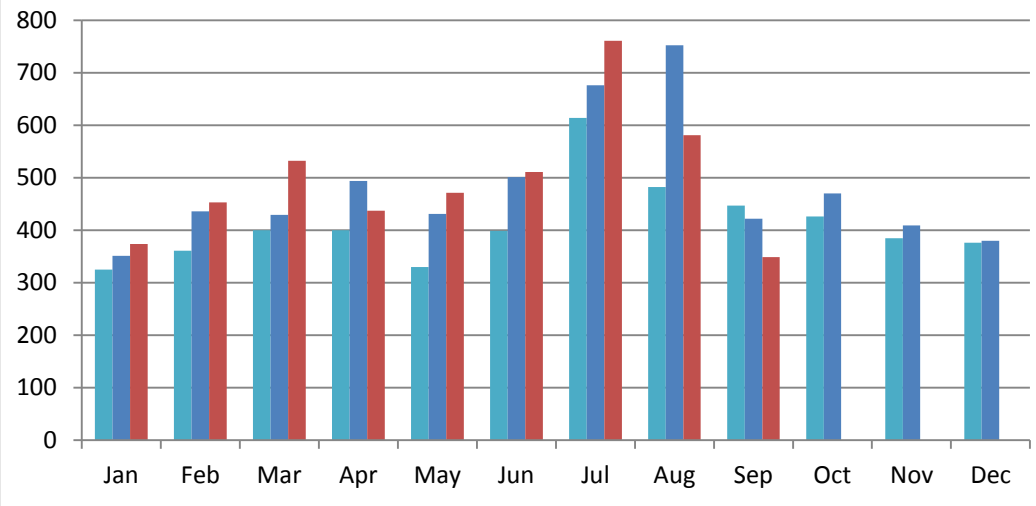

## Circulation

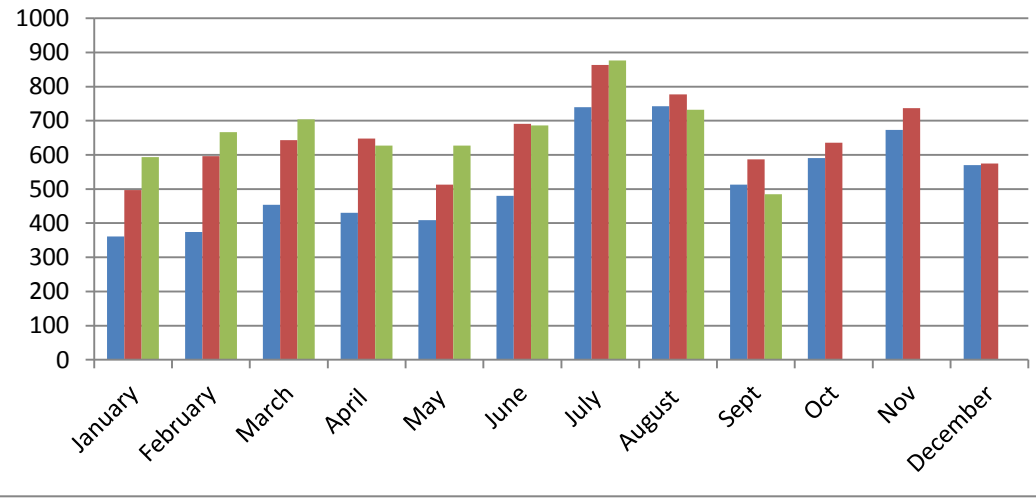

## Meriden Library Stats

### Visits

	January	February	March	April	May	June	July	August	Sept	Oct	Nov	December	Total
<b>Patron Visits</b>													
Adults	316	348	434	316	374	348	429	349	291				3205
Young Adults	6	8	14	15	17	31	58	37	4				190
Children	52	97	84	106	80	132	274	195	54				1074
<b>Total</b>	374	453	532	437	471	511	761	581	349			0	4469

### Circulation

	January	February	March	April	May	June	July	August	Sept	October	November	December	Total
<b>Adults</b>													
Fiction	185	144	181	171	154	160	208	143	149				1495
Non-Fiction	45	48	66	49	51	29	33	34	32				387
<b>Children</b>													
Fiction	204	238	244	196	242	304	398	301	158				2285
Non-Fiction	37	66	59	55	33	44	65	59	38				456
DVD	63	88	68	66	63	58	81	59	52				598
Magazine	22	20	13	12	25	18	22	28	10				170
ILL incoming	15	38	43	62	32	32	23	78	33				356
Audio	22	25	30	16	27	41	46	30	13				250
<b>Total</b>	593	667	704	627	627	686	876	732	485				5997
Volunteer Hours		5.5	9.5	10	30	24	24	20.5	26				149.5
New Patrons													

### Programs

	January	February	March	April	May	June	July	August	Sept	October	November	December	Total
<b>Story Time/Play Group</b>	4	2	2	2	1	4	3	5	4				27
Child	9	4	5	5	5	34	29	52	14				157
Adult	7	2	3	4	3	10	9	35	10				83
<b>Book Groups</b>	2	1	2	1	2	1	1	1	1				
Tuesday	6	6	7	8	9	8	7	4	8				63
M/D	10		8		10								28
<b>Special Programs</b>		2	1	1		1	2	1					8
Children		13	11	10			35	8					77
Young Adult							2						2
Adult		5	42	6		2	26	10					91
<b>Genealogy</b>	3	1	2		2	2							10
<b>Fiber Art</b>	5	2											7
<b>Total Attendance</b>	40	31	78	33	29	56	108	109	32				516
<b>Total Programs</b>	8	7	6	5		7	6	7	5				51

### Philip Read Memorial Library 2012 Patron Visits

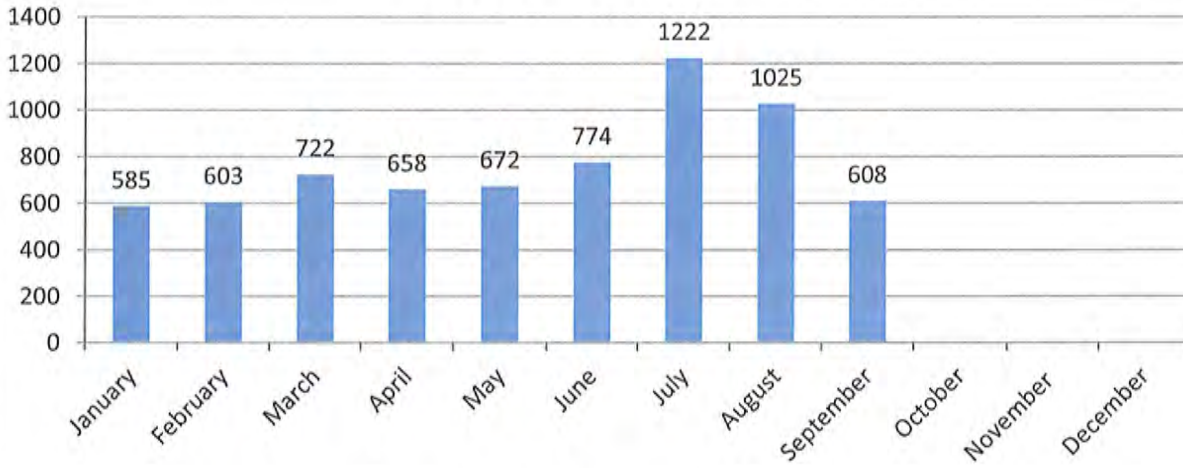

### Philip Read Memorial Library 2012 Circulation

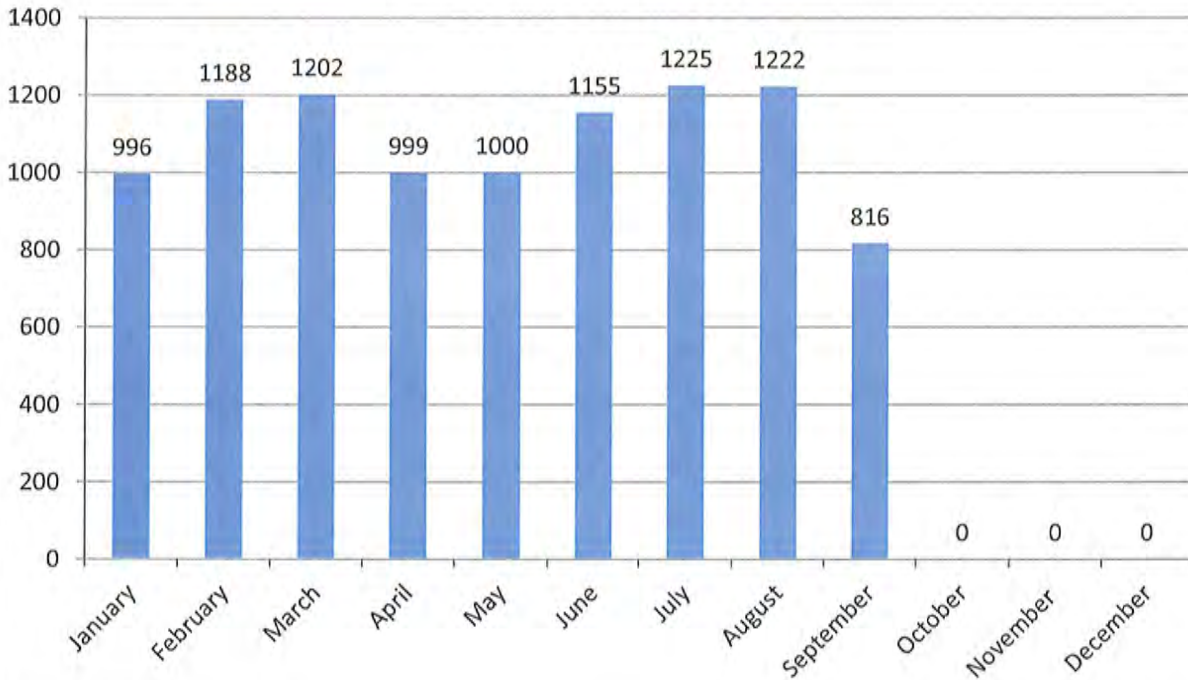

# Patron Visits

	January	February	March	April	May	June	July	August	September	October	November	December	Totals to Date
All	585	603	722	658	672	774	1222	1025	608				6869
<b>Circulation</b>													
Adult	217	265	271	208	276	260	232	223	183				2135
Fiction	65	76	56	42	64	77	70	63	57				570
Non-Fiction	39	40	33	24	40	31	37	33	24				301
Audio	176	219	169	161	134	234	172	159	139				1563
Movies													0
Children	298	360	406	345	255	302	386	439	229				3020
Print	53	53	61	63	61	80	107	106	50				634
Movies	3	8	19	8	10	11	22	24	16				121
Audio	128	144	149	127	136	134	157	152	89				1216
Magazines	3	4	5	1	6	3	8	7	6				43
Other													0
ILL	14	19	33	20	18	23	34	16	23				200
Loaned													
Totals	996	1188	1202	999	1000	1155	1225	1222	816	0	0	0	9803
ILL Borrowed	17	28	36	49	47	44	16	27	23				287
Computer Users	75	74	81	86	79	123	122	115	83				838
Automation items added							to date	663 coming					
Automation Vol. Hrs.							to date	55	18				73
Items Weeded							to date		368				368

**DIRECTOR'S REPORT**  
**PHILIP READ MEMORIAL LIBRARY**  
**October 2012**  
**Activitiy and Statistics for September 2012**

1. Programming: September was very successful. The "Lorax" movie went very well. We also had good attendance at the Cellar Hole program and the math and science teaching workshop. October will be even busier. Upcoming programs: Presentation of the Civil Air Patrol Cadet Program, VINs program with live owls, Poe mystery theater, and felting classes every Wed. night, and the Big Read.
2. Web Page: Mike Sutherland has been working very hard and it is almost ready to launch. I met with him today to go over details and the information I will be sending him to add. Facebook: Teagan will be home in two weeks and will work with me.
3. Automation and other projects: All projects are moving along steadily. I have added lines on the Statistics page for the monthly updates on these figures.
4. Patron Barcoding: Mary and I met to refresh my memory of the procedure and to see how it was working. I will be ordering some supplies and will be starting this shortly.
5. Aide Job Description: Mary and I met to revise the job description. A revised draft is ready.



**ATTORNEY GENERAL  
DEPARTMENT OF JUSTICE**

33 CAPITOL STREET  
CONCORD, NEW HAMPSHIRE 03301-6397

MICHAEL A. DELANEY  
ATTORNEY GENERAL



ANN M. RICE  
DEPUTY ATTORNEY GENERAL

September 25, 2012

Meriden Library Trustees  
Meriden Library Director  
c/o Ms. Anita Brown  
PO Box 88  
Plainfield, NH 03781

Re: Town of Plainfield  
Meriden Public Library

Dear Trustees and Director:

Thank you for meeting with me on September 12 for purposes of discussing the analysis vs. appropriation issue as it pertains to the Meriden Public Library.

At our meeting Trustee Mark Pensgen explained the process used by the Trustees to separate the public funds from the private funds for the period 1990 – 2011. The Trustees' extensive research, based on all available records, concludes that \$6,423.62 is the net balance of unspent public funds in the custody of the Meriden Public Library.

After reviewing the information provided by the Trustees to this office it is our conclusion the \$6,423.62 total contains no private gifts, bequests, or donations, and may therefore be returned to the general fund of the Town of Plainfield.

If you have any questions please do not hesitate to contact me.

Very truly yours,

A handwritten signature in blue ink that reads "Terry M. Knowles".

Terry M. Knowles, Assistant Director  
Charitable Trusts Unit  
(603) 271-3591  
Direct Fax: (603) 223-6221  
terry.knowles@doj.nh.gov

TMK

**Board of Trustees  
Plainfield Town Libraries  
September 17, 2012; 7:00PM • Philip Read Memorial Library  
Approved Minutes**

Attending: Anita Brown, Kara Toms, Mark Pensgen, Hillary Sundell, Nancy Liston, Nancy Norwalk (Director of Philip Read Memorial Library)

Members of the Public: Dennis Girouard

A. Call to Order 7:09PM

1. Minutes of September 10, 2012 meeting were accepted with changes Sec. 5, b change “numbers’ to “cost of new”. MOTION: to approve as amended by Hillary, Kara seconded, Mark abstained (not at the meeting) The vote carried.

2. Correspondence: Discussion on outgoing correspondence with website e-mails. Kara will forward to Nancy L. & Hillary the past e-mails going to BOT via website – Susanne Spenser, Judy Hallem, Andrea Keen, Liz Pasqueeny.

a. Bernadina and Kim are now off website and Hillary and Nancy L. in their places.

3. Summary of September 5, 2012 meeting with Selectboard – Mark summarized.

Discussion as to whether summary notes on meeting with Selectboard should be posted or not – answer Yes. Sidenote: ML “Friends” has not been approved yet for 501 3c – lengthy process.

4. Summary of September 12 meeting with Terry Knowles; Mark took lead on discussion.

a. Kara suggested one possibility that since the discrepancy of funds was due to the unexpended funds of Betty Ann’s salary, would the taxpayers go for a circulation desk in her honor?

b. Mark’s suggestion for the offset towards the next year’s budget to bring these items into line.

c. Overall, Terry was pleased with our outcome.

5. Public Comment: None

6. Announcement to go into Non-public session RSA 91:A-3,II (c )

Specific Statutory Reason cited as foundation for the nonpublic session:  
RSA 91-A:3,II (c ) *Matters which, if discussed in public, would likely affect adversely the reputation of any person, other than a member of the public body itself, unless such person requests an open meeting. This exemption shall extend to any application for assistance or tax abatement or waiver of a fee, fine, or other levy, if based on inability to pay or poverty of the applicant.*

B. Reports for PRML

1. Financial - Nancy N. mentioned that we change amount from Friends from gift to construction. No problem to make change.

a. New “Encyclopedia” came out of “Fines” which is “private” money, which still must be listed but not encumbered. Mark to add a category in

“income” Discussion on how to describe private monies and still list on budget line items. ie: encumbering funds – first in and first out. Nancy N. mentioned that confusion will ensue if we do not have a separate line items for “Trust” / “Fine” type items. “Fine income – Fine expense”

- b. All already “approved” construction monies still have to be budgeted.
- c. Mark and Hillary to bring back to BOT ways to streamline financials.
- d. Mark questioned turn around time in paying the vendor – system is now David G. to approve and then Diane “Friends” to submit check to BOT. If Mark knows ahead of time can submit check to vendor in timely manner.

MOTION: Kara to approve Treasurer’s Report as amended, Anita seconded, the vote was unanimous and carried.

2. Meriden Financial: Ok’d by Mary, show offset transfer fund category?

MOTION: Anita moved to as accept as amended, Kara seconded. The vote was unanimous and carried. Mark made note to see bottom line for expenditures no offsetting income. Offset 46,00 transfer of funds to building funds.

3. Director’s Report – 3 quotes for energy lighting..

Automation of Collection – looking for monthly totals. Discussion on summer heat effect on the PRML building with or without windows being open.

Discussion on Energy Audit Report. Current one, still waiting on report.

Grants available.

- a. Weeding Process – asked Mary for monthly updates, asking Nancy N. for same.

- i. Nancy L. asked if there was a “Weeding policy” answer; in the “collection policy”

4. Finance Subcommittee report – Any questions?

- a. Magazines – Discussion on variety and on prices. – Time/Warner has higher prices. Otherwise all mags. are at a reasonable price, less time consuming to write one check.

- b. Discussion on combining bank accounts for both libraries – Nancy N. has concerns about combining accounts. Mark will get clarification from Terry Knowles.

5. Facilities Report – Discussion on status of egresses, Dennis gave a summary of the Building Committee mtg. with The Friends.

NOTE for Budget: Mark to get numbers for future construction for 2013.

MOTION: Kara moved to accept Reports and Hillary seconded. The motion was unanimous and carried.

#### C. PRML Library: Detailed Discussion

- 1. Nancy N. has bill from David Grobe for signature and then to Town for payment.

- 2. Anita & Hillary to put together volunteer “luncheon”. Nancy L. to check schedules.

3. Nancy N. described a request from Jane Stephenson for “Curtains without Borders”. Board felt not appropriate to hang permanently in either Library.

4. Automation Update: Discussion on how many volunteers and how to speed up process. Nancy N. was asked what she thought would help, more paid hours to process books; add program onto a third computer; Mark to see if there was any monies left over for substitute/aid hours. Labor Laws discussed, question; Can a Trustee be here as a supervisor for a “volunteer” when library is closed? Nancy L. to check with Labor Department.

i. Discussion on how to “market” for more volunteers.

ii. Nancy to start up the process of Patron Barcodes. BOT would like to see an update for next month’s report.

D. Old Business:

1. Weeding of Books/Materials Update: Nancy N. to track weeding per month, also to set up a Patron hourly tracking flow chart.

2. PRML Basement: next steps

3. Marketing: Nancy L. working with Mike Sutherland on setting up e-mails for website. Nancy N. will be working with Teegan Atwater to set-up Facebook page for PRML.

E. New Business/Announcements:

1. Nancy N. turned in her Job Description for Aide.

2. Budget 2013 Preliminary Discussion: LUV meetings/ hotel stays etc. get an approximate figure.

3. Time card discussion (new), Nancy N. to sign for Aides.

4. New Meeting Date is October 1, 2012 at Plainfield Elementary School at 7:15pm.

F. Non-public session per RSA 91-A:3,II (c )

MOTION to enter Non-public session made by Kara, seconded by Mark  
Specific Statutory Reason cited as foundation for the nonpublic session;

*RSA 91-A:3,II (c ) Matters which, if discussed in public, would likely affect adversely the reputation of any person, other than a member of the public body itself, unless such person requests an open meeting. This exemption shall extend to any application for assistance or tax abatement or waiver of a fee, fine, or other levy, if based on inability to pay or poverty of the applicant.*

Roll Call vote: Anita Brown – Yes  
Kara Toms - Yes  
Mark Pensgen – Yes  
Hillary Sundell - Yes  
Nancy Liston – Yes

MOTION was unanimous and carried.

MOTION – Mark moved and it was seconded to return to public session per RSA 91-A:3 II.

Roll Call vote: Anita Brown – Yes  
Kara Toms - Yes

Mark Pensgen – Yes  
Hillary Sundell - Yes  
Nancy Liston – Yes

MOTION was unanimous and carried.

MOTION – It was moved and seconded per RSA 91-A:s III to seal the minutes from the non-public session.

Roll Call vote: Anita Brown – Yes  
Kara Toms - Yes  
Mark Pensgen – Yes  
Hillary Sundell - Yes  
Nancy Liston – Yes

MOTION was unanimous and carried.

Discussion on future uses of the PRML basement and the front room “Maxfield Parrish” room.

MOTION to adjourn made and seconded.

Adjourn: 11:02pm

Next Meeting: October 1, 2012; 7:15pm; Plainfield Elementary School

hs

**Board of Trustees**  
**Plainfield Public Libraries**  
**Approved Minutes**  
**September 10, 2012**

Attending: Anita Brown, Kara Toms, Hillary Sundell, Nancy Liston, Mary King (Director of Meriden Library)

Absent: Mark Pensgen

Members of the public; Steve Beaupré, Rachel Stoddard, Andrea Keen, Dennis Girouard

Convene; 7:11pm

- A. Introduction of guests, Agenda approved.
  - B. Approval of August 6, 2012 Minutes with the corrections. Moved Kara, seconded Nancy L. The motion was unanimous and carried.
  - C. Correspondence
    - a. Rec'd 3 e-mails on ADA compliance. Discussion on issues with automatic e-mail referrals. Nancy L. to contact Mike Sutherland about adding Hillary & Nancy L. names to website e-mail list, remove Bernadina & Kim.
    - b. Andrea Keen spoke about her e-mail, ADA compliancy & PlainFacts disbursal at Libraries.
    - c. Mary introduced Thank you letter received from the Meriden Community Camp that used the library during the summer.
  - D. Kara briefed us on meeting with Selectboard.
    - a. Selectboard suggested that we come up with "Charge" soon.
    - b. Selectboard will appoint a committee once the Charge has been received by BOT.
    - c. Discussion on Judy Hallem's letter that was presented at Selectboard mtg. (attachment)
  - E. Public Comment: Dennis noted that Judy Hallem's letter mentioned a possible temporary ramp (that within the guidelines of ADA that this meeting here was not public accessible) and would a ramp would work. Discussion followed. Trustees will look into alternate meeting site with ADA compliance for the Meriden Library trustee meetings. Dennis asked if it were possible to have a better alert system if and when there are changes to the time and location of meetings. Discussion followed with result that we look at all avenues
2. Reports for Meriden Library
    - A. Financial Report to be added to September 17 agenda, due to Mark's absence.
    - B. Director's Report: (Attached) Nancy L. asked if it was possible to have the number of books automated to show a monthly count since the current count is the full one and show the changes from month to month. Agreed. Discussion on volunteers' hours for updating on automation.
    - C. Facilities Report: Kara responded; no report other than Tom Lapin setting date for improvements on door handles and more.
  3. Meriden Library: Detailed discussion

a. Memorial fund monies received on behalf of Vera Chellis - \$800.00. The family asked that we wait until everything is in and then the family will discuss dispensation. Motion to Accept by Kara; Anita seconded; the motion was unanimous and carried.

b. Automation Update – Mary noted that a go-live date might be mid-November. Meriden going live will affect PRML. Suggestion of placing a statement that this is a “work in progress” on the website was discussed. Mary to check on this.

i. Patron cards – Mary doing big push on cards. Discussion on how PRML will be affected until PRML goes live. Questions on barcoding for patron cards to be placed on agenda for next meeting 9/17/12

c. Weeding – Staying ahead “barely”; Picture Books are big.

#### 4. Old Business

a. Patron visits – timeline – summer vs. winter per hour – Mary has not had a chance to define yet. – Suggestion was to start with hour slots.

b. Meeting with Terry Knowles, Trustees Brown, Sundell, Liston and Pengsen and director King will be going on Wednesday, September 12.

#### 5. New Business

a. Library Aide Performance evaluations – Anita to set up a time to meet, after job description from Library Directors. Nancy L. would like a copy of job description to look over.

b. Budget – Training and development – discussion on what needs are for the Directors for training and development. Kara wants to know cost for new circulation desk. Mary would like guidelines from the Trustees on what would be suitable for training i.e.; hotels, distance etc; Kara suggests a 3 series budget--starting with a 0% increase, midpoint and then 5%.

Discussion on setting aside a line item for Trustees professional meetings and NHLTA membership fees.

Preliminary discussion on “Charge” to a study committee for the ADA compliance for Meriden Library and the Plainfield Library system at large.

Nancy L. suggested the following possible Mission/Charge statement –

“To examine the current library service in Meriden and evaluate all alternatives to provide ADA accessible services.”

Discussion on Wi-Fi - not strong enough for multiple devices. Hillary to stand in for both libraries at meeting on September 19 with Comcast.

Possible conflict with October Meeting date – Columbus Day Holiday; please check calendars for a better date.

Motion to adjourn; Nancy to Move, Kara to second. Unanimous.

Adjourn: 9:02pm

Attachments: (3) Meriden Reports

Letter from Judy Hallem

Steve Halleran

From: judehallam tds.net [judehallam@tds.net]
Sent: Monday, September 03, 2012 11:35 AM
To: Steve Halleran
Subject: ADA/MERIDEN LIBRARY

Dear Steve,

It is unlikely that I will be able to attend this week's Selectmen meeting. I had wished to address the library situation and clear up misconceptions about the ADA. Would you be so kind as to read the following or give a copy to those present and include my original letter:

I, Judy P. Hallam, submitted a request to the Library Trustees and Town Administrator in March of 2009 that the Meriden Library be made accessible to those with walking disabilities. (see letter below). The library offers not only the use of books, but clubs, demonstrations, educational programs and other social events none of which can be participated in by someone like myself in a wheelchair, someone using a walker, crutches or an elderly person unsteady on their feet. It has been 52 years since the library's construction and I feel that 52 years is too long to continue to be inaccessible.

Not wishing to place an undue burden on the trustees or taxpayers, however, I did my homework before I made this request. I did not wish to open the proverbial can of worms... Lawyers at the NH Disability Rights Center assured me that the ADA allows flexibility and latitude in it's law and understands the parameters of an older building such as the Meriden Library. Offering a ramp or other means of access should not be a cause of alarm or does not mean creating a domino effect as suggested by Dennis Girouard in his September Plain Facts article. This is an erroneous misunderstanding of the law. He is correct in the fact that the interior of the library has it's limitations, however. I explained the small size of the interior and told the lawyers that tearing out the bathroom or moving shelves was impractical - it only provides chaos! They understood, but told me that in order to be compliant under the ADA, the meetings, socials, discussions, clubs, etc. are required to be held at a location that is accessible.

I have been in touch with Josh Safdie Director of Institute for Human Centered Design Architecture Studio in Boston jsafdie@HumanCenteredDesign.org.

"The Institute for Human Centered Design (IHCD) is an international non-profit organization committed to advancing the role of design in expanding opportunity and enhancing experience for people of all ages and abilities through excellence in design. Our educational, consulting and design work is very diverse." As a non-profit, their costs are lower.

In his reply to me "we could act as architects for the addition if that is the stage they are at, or we could help them with a building evaluation / feasibility study /schematic design, which they might use to produce an RFP for the project and/or to pursue funding".

Jillian Shedd is the Accessibility Specialist Governor's Commission on Disability with whom I have also spoken. She is also willing to come to assess the situation make suggestions and guide the committee. Main: 603.271.2771 Direct: 603.271.4177 Email: Jillian.Shedd@nh.gov .

Biebel Builders Inc. is a local design and construction firm in Windsor, Vermont. They have constructed numerous local buildings- the chapel at Singing Hills, the red church in Plainfield on 12A - conference centers, schools, churches, residential homes and commercial construction throughout Vermont and New Hampshire. They provide complete design services through to construction. http://biebelbuilders.com/index.php 802-674-9155

I met with and explained this to Mary King and trustees some time ago. I know they are working on this dilemma. While this has taken three more years since I first spoke to them and this situation continues to be unresolved, I am hoping one is impending.

Thank you.

Sincerely,
Judy P. Hallam

\*\*\*\*\*

ORIGINAL LETTER

PO Box 310
Meriden, NH 03770
March 8, 2009

To the Administrators, Trustees and Librarian of the Meriden Library:

As each of you know, this year's political hopefuls ran on the platform of a call for "Change". While I have no intention of running for office, I do wish to continue in an effort to unfurl that banner.

Our library was built many years ago by hardworking townspeople and dedicated volunteers - many of whom continue to work on its behalf. As an eighteen year resident of the town I, too, have volunteered my time, donated books and artwork to support this local institution. Over the years it has evolved into an important center and core which offers, not only books to read, but other educational and social aspects of the of the Meriden community. However, for over forty four years, it has also stood as a barrier to those of us who sit in a wheelchair, the elderly, or others who are not able to traverse it's stairs - to peruse it's bookshelves, do research on the computer, participate in socials, fund raisers, discussions, or any other community event taking place within its walls.

Just as previous residents came together to build this edifice, I ask your help in making it accessible. Instead of accepting the status quo, could we come together to brainstorm common sense, low cost approaches to providing access to all of us in the Meriden community? I am not asking for a wrecking ball but rather one of the many definitions of the word "Change" - "to make something pass from one state or stage to another". While, I wish you good health and mobility, there may come a time in each of your lives that you will have difficulty. I am calling upon you, now, to help bring about this empowering word of action.

Respectfully,
Judy Pollock Hallam
(469-3953)

9/5/2012

cc Stephen Halleran/Town Administrator, Jane Stephenson/Planning Commission, Robert Taylor/ Board of Selectmen, Stephen Beaupre/ Finance Committee



Meriden Library  
Director's Report  
August 2012

August Statistics Attached.

Programs: On Friday, August 10, Rick Hunter from the Stellafane Astronomy Club in Springfield, VT, presented "Exploring the Night Sky", an evening program at the Meriden Library. 18 patrons attended. Families enjoyed a pot-luck dinner before the start of the program. We planned for an outdoor program but the weather was bad so we needed to move the program into the children's room. As part of his presentation Rick demonstrated computer software that did allow for viewing of a simulated night sky.

This year we did not take a summer break from story hour and we had great attendance throughout the month. On Thursday, August 9 several young participants of our summer reading program put on a performance as part of story hour.

Automation: On August 29, I met with Pam Smith at the Howe Library to plan next steps to prepare for "going-live" with the Evergreen software. We developed a time-line that will have the Meriden Library using Evergreen for circulation by mid-November. Before a date can be set for us to go-live the Howe Library needs to go through an up-grade to the software and then have time to work out any bugs in the up-grade. We will have a firm date once Howe has scheduled the upgrade with Equinox, (expected to be by mid-October).

Our volunteers devoted more than 20 hours to cataloging books in August. We continue to add materials with the highest circulation, adult fiction and juvenile picture and chapter books, as well as all new materials.

The Meriden Library report of items cataloged in Evergreen as of 9/4/12:

<b>Owning Library</b>	<b>Description</b>	<b>Items Added</b>
Meriden Library	CD Audio book	143
	DVD	178
	Book	2059
		<b>2380</b>

# Meriden Library 2010 - 2012

## Visits

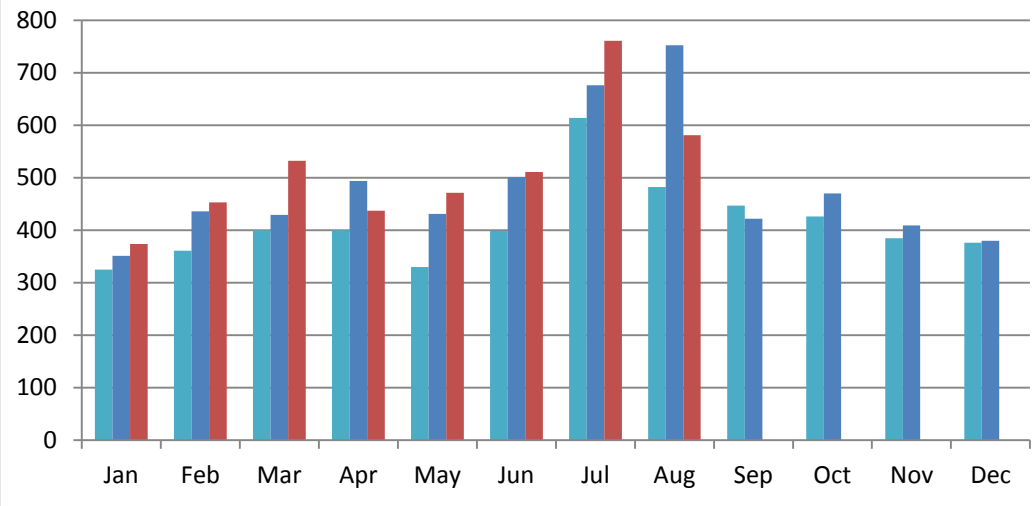

## Circulation

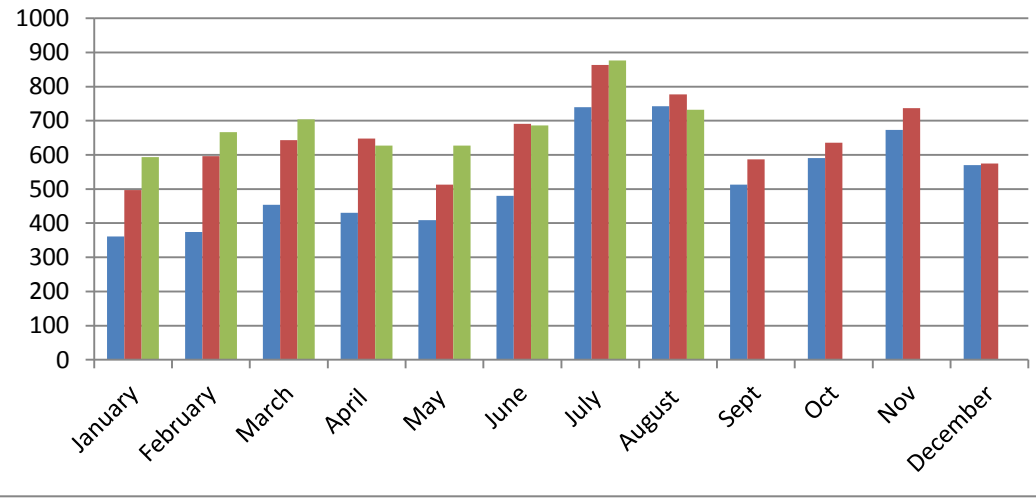

## Meriden Library Stats

### Visits

	January	February	March	April	May	June	July	August	Sept	Oct	Nov	December	Total
<b>Patron Visits</b>													
Adults	316	348	434	316	374	348	429	349					2914
Young Adults	6	8	14	15	17	31	58	37					186
Children	52	97	84	106	80	132	274	195					1020
<b>Total</b>	374	453	532	437	471	511	761	581				0	4120

### Circulation

	January	February	March	April	May	June	July	August	Sept	October	November	December	Total
<b>Adults</b>													
Fiction	185	144	181	171	154	160	208	143					1346
Non-Fiction	45	48	66	49	51	29	33	34					355
<b>Children</b>													
Fiction	204	238	244	196	242	304	398	301					2127
Non-Fiction	37	66	59	55	33	44	65	59					418
DVD	63	88	68	66	63	58	81	59					546
Magazine	22	20	13	12	25	18	22	28					160
ILL incoming	15	38	43	62	32	32	23	78					323
Audio	22	25	30	16	27	41	46	30					237
<b>Total</b>	593	667	704	627	627	686	876	732					5512
Volunteer Hours		5.5	9.5	10	30	24	24	20.5					123.5
New Patrons													

### Programs

	January	February	March	April	May	June	July	August	Sept	October	November	December	Total
<b>Story Time/Play Group</b>	4	2	2	2	1	4	3	5					23
Child	9	4	5	5	5	34	29	52					143
Adult	7	2	3	4	3	10	9	35					73
<b>Book Groups</b>	2	1	2	1	2	1	1	1					
Tuesday	6	6	7	8	9	8	7	4					55
M/D	10		8		10								28
<b>Special Programs</b>		2	1	1		1	2	1					8
Children		13	11	10			35	8					77
Young Adult							2						2
Adult		5	42	6		2	26	10					91
<b>Genealogy</b>	3	1	2		2	2							10
<b>Fiber Art</b>	5	2											7
<b>Total Attendance</b>	40	31	78	33	29	56	108	109					484
<b>Total Programs</b>	8	7	6	5		7	6	7					46

Board of Trustees  
Plainfield Public Libraries  
Approved Minutes  
August 6, 2012

Attending: Anita Brown, Kara Toms, Mark Pensgen, Hillary Sundell, Nancy Liston

Members of the Public: Dennis Girouard

Convened at 6:46pm

A. Review Election of Officers

Chair – Anita

Vice-Chair – Kara

Treasurer – Mark

Secretary – Nancy L. was asked if she would like the position, she declined; Hillary will be Secretary, with Nancy & Anita to help with Correspondence.

Nancy L. – Roving Reporter, PlainFacts Articles.

B. Review Selection of Working Groups

Human Resources – Anita & Mark

Technology, Automation & Collection – Nancy L. & Mark

Financial – Mark & Hillary

Facilities – Kara & Anita

Marketing – Kara

Policies – Hillary & Nancy L.

C. Other Responsibilities

Trustee Liaison to Friend's Groups – Kara & Mark to ML, Nancy L. to PRML. If the designated Trustee not available, then another Trustee will fill in.

Trustee Liaison to Building Committees – Kara to ML, Anita to PRML.

D. Discussion of Budget and Accounting Structure

1. Hillary & Mark to meet about future set-up of books for both Libraries & Banking. Questions on one account for both libraries versus separate accounts. Currently have 2 separate Tax ID#'s for each library; NH State says we can use Town ID #. The current process is that we receive a check from the Town addressed to PRML, deposited into PRML account then a check is issued to ML.

2. For Budget notes; Anita would like to see line item monies set aside for BOT uses such as; computer, trustee professional expenses & activities. Defer discussion for budget meetings.

Nancy asked if the Trustees had to be bonded? Mark is bonded through the Town.

E. Discussion of Schedule and structure of meetings

September 10, 2012 – Meriden – 7pm

September 17, 2012 – PRML – 7pm

October 8, 2012 – Regular Meeting at ML – 7pm

November 5, 2012 – Featured Library – ML

November 7, 2012 -Featured Library – PRML

December 10, 2012 – Regular Meeting at – PRML – 7pm

When is meeting with Terry Knowles in Concord, Wednesday, September 12. Meeting not confirmed yet. Other meetings for budget not designated yet, also a meeting with the Finance Advisory Board from Town usually in October.

Mark & Hillary to meet before October 8 meeting with Directors. Budget discussion, Staff needs vs. Board needs. Discussion on volunteers vs. paid employees to speed up automation. Is the current structure working? Need to have agenda out 2 weeks in advance, all Directors Reports and other reports to be read in advance of meetings, don't need discussion. Kara repeated request to have 2 additional Trustees added to lighten workload, followed by discussion; consensus: larger board, more complicated; leave as is for now.

F. Roll Call and approval of agenda

1. June 11 Non-sealed & Sealed minutes. Hillary moved to accept, Kara seconded, Nancy L. abstained, Approved.
2. July 9 Sealed minutes, Nancy moved to accept, Anita seconded. Approved
3. July 16 Non-sealed & Sealed minutes, Nancy L. moved to accept, Anita seconded. Approved.

G. Donations – PRML

1. Mark asked what the actual donation is, what does it entail? Anita answered it covered the egresses on both sides of Building. Discussion as to technicalities of liability for who is responsible for payment. Mark wanted to know the right path for payment – Either the Friends or Trustees?

NOTE: For the Meeting in Concord with Terry Knowles “To be bonded with regards to assuming liability on payments on current discussion”.

Was the original scope of the work accepted? Kara suggests we put the money in the account and pay the bill.

Anita Moved to accept the \$48,184.08 from The Friends of Philip Read Memorial Library Group for the Purpose of Basement Renovations, Hillary Seconded.

Roll Call to Vote: Anita Brown – Yes  
Kara Toms – Yes  
Mark Pensgen – Yes  
Hillary Sundell – Yes  
Nancy Liston – Yes

H. Directors Reports

1. Nancy L. & Mark have issues with pace of Automation too slow. Mark to intercede between Librarians. Nancy L. & Mark to meet with Nancy N. to work on Timeline for Automation. Nancy L. felt that Item #7 is a worthwhile meeting for the Librarians to go to. Mark would like to see more time spent on #5. Discussion on The Library Convention. Mark suggests both Directors go to promote unity; Anita will touch base Mary and Nancy (NELib.org). *Attachments*

NOTE: Kara suggested that we put this conference in the budget for next year.

I. Action Items

1. Fuel Oil Contract – Discussion on whether both libraries to go with prebuy. Suggested that PRML go with prebuy, as that usage is undetermined for ML. Kara mentioned that Mary wanted to get in touch with Simple Energy. Mark moved that we prebuy from Irving for PRML, Kara seconded. Hillary to call Mark for usage by PRML last year to set gallons. All voted, Nancy L. voted no, Nancy L. felt that the information had been gathered and we should move ahead with one contract for both libraries based on price. Waste of time for both Trustees and Librarians to duplicate efforts. The motion carried. *Attachment*

2. Estes & Gallup – Anita to sign for payment of \$16,267,07. For Estes & Gallup.

J. Policy Review – All 3 Policies passed and still need to be signed.

1. Need a folder for Suellen and a copy for Nancy N.

K. Anita voiced the review of meetings in the past with Non-Public minutes that Dennis had questioned at the July 9 meeting.

RSA 91-A3, II (c) – Anita will write up formal reply and give to Dennis.

L. Vision of the Future of the Plainfield Public Libraries

1. Discussion of Kara's timeline for making ML ADA compliant. Anita shared the history of the renovation of PRML, steps that were taken by the committees/study groups and the Town.

2. Kara wanted to keep moving, concerns with patrons that would like to use ML, but cannot. Thoughts on getting the "Buzz" going in October, perhaps an article in PlainFacts? Dennis suggested that we go to the Town at Annual meeting to ask for public support after we have done the research.

3. Survey was done 2 years ago. Mark suggested focus groups to go out into the community. Anita suggested an Open meeting with Vision of Libraries as well as making ML ADA compliant. Suggested that we ask Paul (Town Moderator) for his input of appropriate members to be selected for a study group. We will also add ourselves to Selectboard Agenda for the Sept. 5 meeting.

Anita moved to adjourn, Mark seconded.

10:09pm all agreed.

Library specific meetings:

September – 2013 – Budget Focus

September 10, 2012 – Meriden – 7:00pm

September 17, 2012 – PRML – 7:00pm

Next Regular Meeting: October 8, 2012; Meriden Library; 7:00pm

Attachments: (5)

ML Directors Reports (3)

PRML Directors Report (2)

Fuel Bid

Board of Trustees  
Plainfield Public Libraries  
July 16, 2012  
Featured Library: Meriden Library

Attending: Anita Brown, Mark Pensgen, Hillary Sundell, Nancy Liston, Mary King,  
Director of Meriden Library.

Members of the Public: Dennis Girouard, Pam Abrahamson & Lee Abrahamson

Convened at 7:08pm

A. Roll Call and approval of agenda

1. June 11, 2012 minutes to be cleaned up and resent to Trustees and then to approve at August 6<sup>th</sup> meeting.
2. July 9, 2012 Minutes approved.
3. Correspondence; Mary had correspondence with Utilities.
4. Public Comments; Dennis asked when his questions from July 9<sup>th</sup> meeting would be answered? Issue will be discussed at August 6<sup>th</sup> meeting.
5. Announcement of Non-public meeting RSA 91:A-3, 11 ( c)

B. Reports

1. Financial; Mark said everything looks good at the 50% mark for the year, discussion on amounts being reflected for new computer and software. Anita mentioned that we send out new adjusted PRML acct. For ML-areas in Audio/visual overspending, everything within budget. Question asked if National Grid bill arrived yet? No. Has there been an impact with the new AC? Unanticipated funds are skewing line items. Anita moved to accept and Nancy I. seconded. The motion was unanimous and carried.

*Attachment*

2. Director's report; Saturday's program June 9<sup>th</sup> "Downloadable Book Program" was not well attended, perhaps the "Walk for Natalie" pulled people away, volunteers are off on vacations. Last of pieces going on to Equinox. ISBN #'s an issue at Meriden also. Not working with older books that have migrated from the system. New books are no problem. Mark concerned about duplicate records, if we are using Library of Congress to find numbers for older books. Any books after 2010 should work fine. Anita asked if we could see if a title prior to 2010, use a different search – not ISBN/739.5 search? Mary stated that the idea was to have less files, use same file for hardcover as for paperbacks.
  - i. Patron Files; Laurie (no volunteers) to add in information on Patrons. Re-issue cards to patrons – Good progress so far.
  - ii. Meriden & PRML #'s will work in either library, first come – any holds on books to whichever library gets the "hold" first.
  - iii. Question; Who or what system to transport books between libraries? Transit tags to attach to books.

- iv. Meriden's collection is about 10,000 books at the moment but would like to come in around 7,000 to 8,000 in collection and around 3,000 in the system when we go live. Mark asked if everything was bar-coded now? Mary stated that all new adult fiction and Juvenal chapter books and working on nonfiction. Blue slash means that book is in the system. Nancy L. asked are you going ahead before whole collection is in? Mary replied; yes, there is a system and hope that Patrons will be understanding.
- v. Statistics; discussion on Campers using books for the summer, Church has an account.

Anita moved to accept and Mark seconded. The Motion was unanimous and carried. *Attachments*

- 3. Facilities; three documents on ADA Construction passed around; ML Timeline, Summary of Meetings, Building needs passed around. *Attachments*

- 1. Maximize light, a small kitchenette, comfortable.
- 2. Summary of meetings with Architects, showed photo of David King's work. Discussion.
- 3. Nancy L. asked if all of the land that the Library sits on is owned by Meriden, Anita answered yes. Nancy asked if a vote was made by the BOT to support this renovation? Anita replied that we have a discussion as joined board to look at both libraries. Mark stated that we have a strong timeline (aggressive) and stick with budgets. Anita suggested a study group, put together information to inform the Town and put into a warrant item for the Town Meeting. Dennis suggested that we explain the 3 yr. Moratorium on Building – check into prior minutes. Mark or Dennis? mentioned that the Town has been putting aside monies for the Meriden Building fund, also Betty Ann's Memorial Funds for her vision of the Library (The 2 Vanguard accounts?)
- 4. Mary asked for clarification on how much money to be obligated for ADA/handicapped compliance? Anita spoke on timeline and grand fathering. Nancy L. No Mechanics? (elevator) is there room to move out back?
- 5. Mary is trying to consult with a library consultant/Space planner.
- 6. Discussion on patrons that want to see this move forward for Meriden to become ADA compliant, or may go a step further. Nancy L. suggested a survey; Anita mentioned that there was a survey discussion when both libraries joined. Nancy L. suggested that ML could be more of an adult library? KUA to open up its libraries more to the Town? Mark thought that the BOT should come up with a "Vision of the future", what are our options? Community centers? Dennis G. stated that The Town has been setting aside \$5,000. annually towards a Meriden L. ADA Compliant Fund



Anita said that the funds from the Town are ADA specific.

7. Back to Facilities Report; Mary would like to reconfigure desk area, get rid of shelving and dedicate to administration. Mark asked if Mary was ready to make the move, schedule a day and do it. Mary will speak to Pam, Equinox and Howe to schedule a date in August to “Go Live”. Nancy L. asked if system had notification via e-mail for soon to be overdue books?

C. Detailed discussion – Directors report;

1. Fall programs – healthy communities to join with Cornish Library. Our program with Steve Taylor in October @ Duckworth Museum, on One Room Schoolhouses.
2. Mark stated that 1<sup>st</sup> priority should be Automation and weeding.
3. Book Sale in the Plans? Used to be in the spring opposite PRML’s one in the fall. Friend’s Group to look into?

D. Old Business; Policies

1. Mark has change in Safety - #9, take out” Library materials will not be stored in the furnace room.” To say ”Nothing can be stored in the furnace room, per Plainfield Safety Committee.” Safety Policy to be voted on in August. Mark moved to approve, Anita seconded. The Motion was unanimous and carried.
2. Children’s policy to be voted on in August.
3. Behavior Policy – Mark moved to approve, Anita seconded.

E. New Business/Announcements

1. Patron Visits; what is difference in usage hour wise? Create an additional form, weather, shifting hours all elements in visits.
2. Change August meeting to the 6<sup>th</sup>. All voted and accepted. Hillary to let Mike Sutherland know to change date on website calendar.
3. Discussion on fuel bids from local companies researched by Hillary. BOT had more questions, Hillary to get more info and to e-mail to Board.

Vote to go into nonpublic session RSA 91-A:3:II ( c) – Anita moved, Hillary seconded.

Roll Call Vote: Anita Brown  
Mark Pensgen  
Hillary Sundell  
Nancy Liston

Motion made by Mark to return to public session, Nancy L. seconded

Roll Call Vote: Anita Brown  
Mark Pensgen  
Hillary Sundell  
Nancy Liston

Motion: PASSED

Public Session reconvened at 10pm

Motion made by Anita to seal the nonpublic minutes, RSA 91-A:3:II ( c), Mark seconded

Roll Call Vote: Anita Brown  
Mark Pensgen  
Hillary Sundell  
Nancy Liston

Motion: PASSED

Move to adjourn by Mark, Nancy L. seconded.

All agreed

Library specific meetings:

September – 2013 – Budget Focus

Sept. 10, 2012 – Meriden - 7pm

Sept. 17, 2012 - PRML – 7pm

Next Regular Meeting: August 6, 2012 at 7:15pm

PRML

Attachments; (9)

Meriden Library Financial Report

Directors Reports (3)

Meriden Library ADA Timeline

Summary of Meetings with Architects

Meriden Building Needs – Wish List

# Meriden Library 2010 - 2012

## Visits

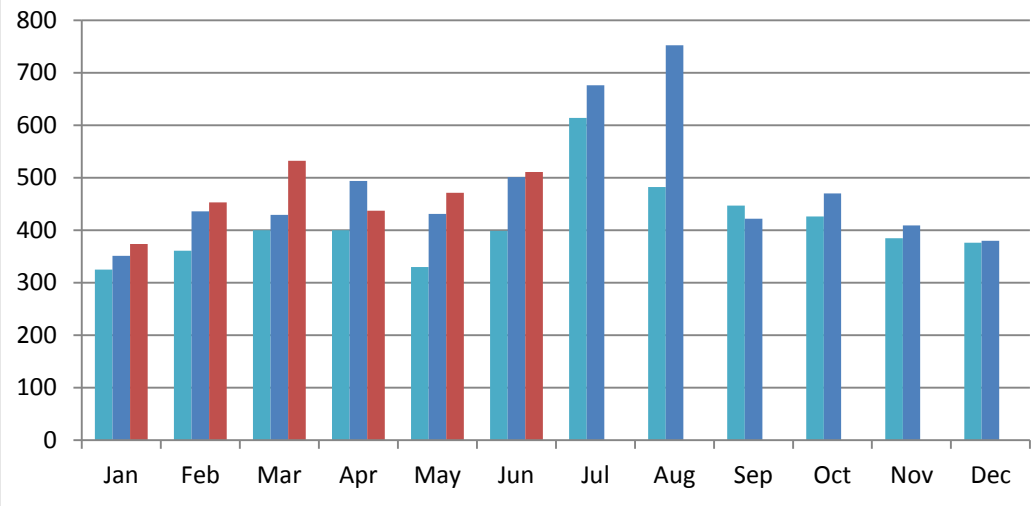

## Circulation

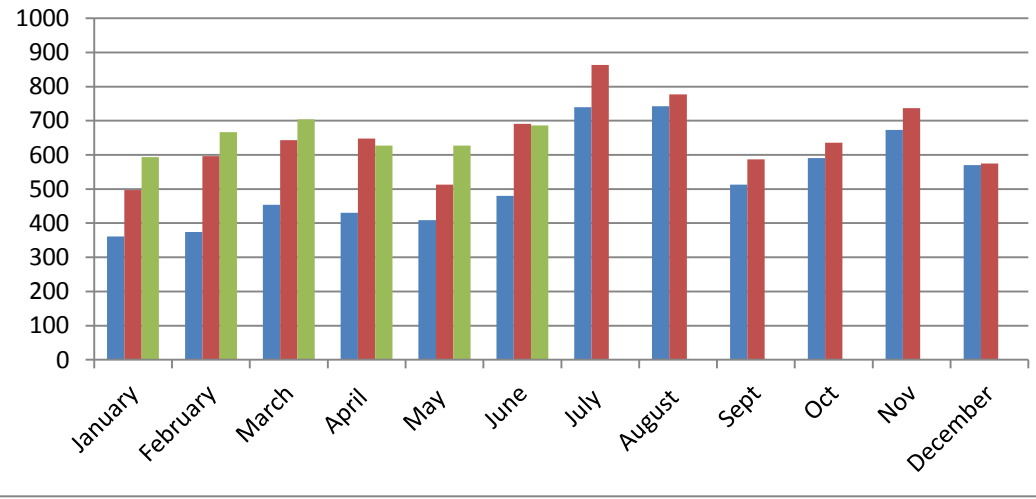

## Meriden Library Stats

### Visits

	January	February	March	April	May	June	July	August	Sept	Oct	Nov	December	Total
<b>Patron Visits</b>													
Adults	316	348	434	316	374	348							2136
Young Adults	6	8	14	15	17	31							91
Children	52	97	84	106	80	132							551
<b>Total</b>	374	453	532	437	471	511						0	2778

### Circulation

	January	February	March	April	May	June	July	August	Sept	October	November	December	Total
<b>Adults</b>													
Fiction	185	144	181	171	154	160							185
Non-Fiction	45	48	66	49	51	29							288
<b>Children</b>													
Fiction	204	238	244	196	242	304							1428
Non-Fiction	37	66	59	55	33	44							294
DVD	63	88	68	66	63	58							406
Magazine	22	20	13	12	25	18							110
ILL incoming	15	38	43	62	32	32							0
Audio	22	25	30	16	27	41							161
<b>Total</b>	593	667	704	627	627	686							3904
Volunteer Hours		5.5	9.5	10	30	24							79
New Patrons													

### Programs

	January	February	March	April	May	June	July	August	Sept	October	November	December	Total
<b>Story Time/Play Group</b>	4	2	2	2	1	4							15
Child	9	4	5	5	5	34							62
Adult	7	2	3	4	3	10							29
<b>Book Groups</b>	2	1	2	1	2	1							
Tuesday	6	6	7	8	9	8							44
M/D	10		8		10								28
<b>Special Programs</b>		2	1	1		1							5
Children		13	11	10									34
Young Adult													0
Adult		5	42	6		2							55
<b>Genealogy</b>	3	1	2		2	2							10
<b>Fiber Art</b>	5	2											7
<b>Total Attendance</b>	40	31	78	33	29	56							267
<b>Total Programs</b>	8	7	6	5		7							33

Meriden Library  
Director's Report  
June 2012

June statistics are attached.

On Saturday, June 9 we held a program to demonstrate the NH Downloadable Book Consortium. Michael Morris, a reference librarian at both the Meredith Library and Howe Library, was the presenter. The program had very poor attendance with only two adults attending.

Work continues on cataloging books into the Evergreen software. The process includes weeding items that have not circulated or are in poor condition. If an item is to be discarded it needs to be removed from the NH Public Access Catalog (NHU-PAC) so every book is being handled in some way. The progress so far has been sufficient but slower than I anticipated.

The last pieces of information that are needed to complete our catalog with Equinox , notices and On-line Public Access Computer configuration, have now been developed. Mark Pensgen, Nancy Norwalk, Mike Sutherland and I met to finalize this outstanding work. Mike is working on the catalog and all of this information will be passed onto Equinox within the next weeks allowing us to schedule a "go-live" date.

The June 29 report of items added:

Meriden Library	CD Audio book	133
	DVD	175
	Book	1204
		1512

Most of my administrative time for June was used to attend meetings about future building needs. Those meeting are described in detail in the Facilities report.

Meriden Library ADA Timeline Guide:

June: mtgs with architects/builders

July:

- decide on architect/builder and respond to all
- have follow up mtg with whom we choose to create a plan
- talk with space planner

August:

- Form "Study Group"
- Identify focus groups
- Plan dates for meetings
- Plan focus group meetings (what data do we want)

Sept:

- Have initial mtg with Study Group
- Focus Groups
- Synthesize data from focus groups

Oct:

- Study Group mtgs,
- Begin conceptual drawings
- Look at \$ (put \$ in budget 2013 for potential expenses)

Nov:

- Finalize conceptual drawings
- Hire development consultant

Dec:

- Explore \$ using conceptual drawings
- Begin to discussion on proposal to town (warrant, etc)
- Talk with builders/get bids

Jan:

- Submit warrant proposal
- Keep working on \$

Feb: \$\$\$

March: Town Mtg

3:25 PM

07/18/12

Accrual Basis

**Philip Read Memorial Library**  
**Treasurer's Report**  
 January 1 through July 18, 2012

	Jan 1 - Jul 18, 12	Budget	\$ Over Budget
<b>Income</b>			
Encumbered Funds 2011	2,404.38	3,194.05	-789.67
Town Appropriation			
Appropriation-Operations	8,550.00	30,330.00	-21,780.00
Appropriation-Salary	15,753.56	33,749.00	-17,995.44
FICA	1,263.29	2,582.00	-1,318.71
Town Appropriation - Other	11,900.00	0.00	11,900.00
<b>Total Town Appropriation</b>	<b>37,466.85</b>	<b>66,661.00</b>	<b>-29,194.15</b>
Trust Fund Income	1,200.00	2,400.00	-1,200.00
Fines	356.28	100.00	256.28
Gifts	160.00	50.00	110.00
Grants	1,550.00	700.00	850.00
Misc Income	62.47	300.00	-237.53
<b>Total Income</b>	<b>43,199.98</b>	<b>73,405.05</b>	<b>-30,205.07</b>
<b>Expense</b>			
Encumbered Funds	3,014.90	3,194.05	-179.15
Payroll			
Salaries	15,753.56	34,749.00	-18,995.44
FICA	1,263.29	2,624.00	-1,360.71
Payroll - Other	0.00	0.00	0.00
<b>Total Payroll</b>	<b>17,016.85</b>	<b>37,373.00</b>	<b>-20,356.15</b>
Library Materials			
Books and Magazines	4,309.96	8,000.00	-3,690.04
Audio Visual Materials	700.81	1,200.00	-499.19
Library Materials - Other	0.00	0.00	0.00
<b>Total Library Materials</b>	<b>5,010.77</b>	<b>9,200.00</b>	<b>-4,189.23</b>
Catalog Services/Automation	405.96	1,500.00	-1,094.04
Supplies	812.53	1,500.00	-687.47
Postage	104.00	250.00	-146.00
Programs	213.76	600.00	-386.24
Professional Activities	340.15	450.00	-109.85
Oil	3,824.84	7,500.00	-3,675.16
Electricity	1,351.47	3,400.00	-2,048.53
Telephone	609.86	1,080.00	-470.14
Water	95.50	300.00	-204.50
Maintenance			
Maintenance-General Expenses	442.44	3,000.00	-2,557.56
Elevator	762.08	1,700.00	-937.92
Maintenance - Other	276.00	0.00	276.00
<b>Total Maintenance</b>	<b>1,480.52</b>	<b>4,700.00</b>	<b>-3,219.48</b>
Furnishings and Equipment	43.99	500.00	-456.01
Computer Hardware and Software	262.00	1,000.00	-738.00
Miscellaneous Expense			
Grants	0.00	700.00	-700.00
Miscellaneous Expense - Other	0.00	200.00	-200.00
<b>Total Miscellaneous Expense</b>	<b>0.00</b>	<b>900.00</b>	<b>-900.00</b>
<b>Total Expense</b>	<b>34,587.10</b>	<b>73,447.05</b>	<b>-38,859.95</b>
<b>Net Income</b>	<b>8,612.88</b>	<b>-42.00</b>	<b>8,654.88</b>

**Philip Read Memorial Library**  
**Treasurer's Report**  
 January 1 through July 18, 2012

	<u>% of Budget</u>
<b>Income</b>	
Encumbered Funds 2011	75.3%
Town Appropriation	
Appropriation-Operations	28.2%
Appropriation-Salary	46.7%
FICA	48.9%
Town Appropriation - Other	100.0%
Total Town Appropriation	<u>56.2%</u>
Trust Fund Income	50.0%
Fines	356.3%
Gifts	320.0%
Grants	221.4%
Misc Income	20.8%
<b>Total Income</b>	<u>58.9%</u>
<b>Expense</b>	
Encumbered Funds	94.4%
Payroll	
Salaries	45.3%
FICA	48.1%
Payroll - Other	0.0%
Total Payroll	<u>45.5%</u>
Library Materials	
Books and Magazines	53.9%
Audio Visual Materials	58.4%
Library Materials - Other	0.0%
Total Library Materials	<u>54.5%</u>
Catalog Services/Automation	27.1%
Supplies	54.2%
Postage	41.6%
Programs	35.6%
Professional Activities	75.6%
Oil	51.0%
Electricity	39.7%
Telephone	56.5%
Water	31.8%
Maintenance	
Maintenance-General Expenses	14.7%
Elevator	44.8%
Maintenance - Other	100.0%
Total Maintenance	<u>31.5%</u>
Furnishings and Equipment	8.8%
Computer Hardware and Software	26.2%
Miscellaneous Expense	
Grants	0.0%
Miscellaneous Expense - Other	0.0%
Total Miscellaneous Expense	<u>0.0%</u>
<b>Total Expense</b>	<u>47.1%</u>
<b>Net Income</b>	<u><u>-20,506.9%</u></u>



## Meriden Library

### Building Needs

#### Wish List for Accessibility/Renovations/Expansion

- One level library
  - Able to be staffed by one person
- Energy efficient (does not have to be LEED)
- Maximize natural light
- Meeting space (flexible)
  - Kitchenette (6' counter with sink, fridge, etc)
- Comfortable reading area
  - Gas burning stove
- Administrative work space
  - Close to circulation desk
- Children's Area with separate space for teens, school aged and preschoolers
  - Story Time Area
- Bathroom (1)
- Outdoor patio?
- Work Stations
- Computer stations
  - 2-3 computers

## Summary of Meetings with Architects/Design Builders

David King (June 12): <http://www.davidkingarchitects.com/public-libraries/>

David has done additions and renovations on several libraries, mostly in MA. There is a library in Worthington, MA that is similar to the ML for which he has done a design for an addition which we really like (see attachment). However, the meeting seemed slow and not very organized. We have some concerns about his ability to present to a group. He also does not have much experience in NH. He quoted about \$200-250/sq ft for an addition, but did not give an amount for the renovations for the original library. The architect fees would be 10% on top, but he said he could be flexible.

Peter Tennant (June 25): <http://www.twarchitecture.com/>

Peter has worked on many library projects in NH and was the presenter at the NHLTA annual meeting on "Libraries of the Future." He clearly has an understanding of the needs of libraries, where the future is leading, and how create flexible spaces to adapt. He also has knowledge in ADA compliance. He was able to quickly identify aspects of the original building for areas of improvement (savings in lighting, asbestos abatement). The meeting was focused and organized. He presented a logical time frame for the process: By Thanksgiving - Big Picture, January - Warrant submission, March - Town Mtg with lots of leg work in between. A conceptual Design Package for \$10,00 includes: 10-15 mtgs, 3 designs, floor plans, presentation drawing, 10 pg study. Here is the breakdown of his estimate for the cost of the project:

- Addition 1500 sq ft: \$375,000 (\$250/sq ft)
- Renovation 1200 sq ft: \$180,000 (\$150 sq ft)
- Site work: \$100,000
- Furniture
- 9% architect & engineering

Bill Knight (June 28): Bill is a local builder/engineer who has overseen many big projects including the Plainfield School. His reputation as a design builder is outstanding. He knows the local contractors and has a vested interest in doing the job right. As a long time resident, he is also familiar with Plainfield. One of his strengths is energy efficient building and he mentioned that it would not be difficult to get a level LEED certification. He had some suggestions as to process such as a "Study Group" (instead of building committee) and to have some focus groups of key patron groups for town buy-in. His experience with libraries is not as extensive as the other architects, so we would also use a library space planner if we went with Bill. He said that he would donate his time for the original design creation and that he would hire a local draftsman to create drawings at minimal cost. His rough estimate for building costs are:

- Addition 1500 sq ft: \$300,000 (\$200/sq ft)
- Renovation 1200 sq ft: \$120,000 (\$100 sq ft)
- Site work: depends on how much we want to bring the building up to grade

## **Safety Policy Plainfield NH Public Libraries**

### Objective:

The health and safety of Library staff, volunteers and patrons is very important. The Plainfield Public Libraries are members of Plainfield's Joint Loss Safety Committee. All staff shall make safety and the safety of their co-workers and patrons a priority. Staff shall conduct their daily tasks in a manner that is consistent with the philosophy and objectives of this policy. The policy is designed to comply with the standards of OSHA to endeavor to maintain a safe and injury / illness free workplace. A copy of OSHA Safety and Health Standard 1910 shall be available for staff use and reference. Enforcement of the Safety Policy is the responsibility of the Library Director.

### Compliance:

Compliance with the Safety Policy is required of all staff and applies to volunteers. Primary responsibility for enforcement of this policy is given to the Library Director. The Director shall:

1. Provide reasonable safe guards for all staff, volunteers and patrons.
2. Conduct health and safety inspections to help identify and eliminate unsafe working conditions or practices, to control health hazards and to comply fully with Safety and Health Standards.
3. Make staff aware of health and safety practices.
4. Develop, update and enforce health and safety rules.
5. Require that all staff and volunteers cooperate with these regulations.
6. Investigate promptly and thoroughly, accidents or incidents to determine the cause and act to prevent any recurrence.
7. Regularly evaluate all areas of safety & make recommendations to the Trustees.

### Staff and volunteers shall:

1. Report all unsafe conditions and practices immediately to the Library Director.
2. Use common sense and care to prevent injury to themselves and others.
3. Keep aisles and exits clear at all times.
4. Immediately report any incidents or injuries to the Director.
5. Be aware of the location of the first aid kit.
6. Be aware of the location of fire extinguishers.
7. Use caution on icy walkways. Sprinkle de-icer on steps.
8. Staff working in the library after closing hours shall lock exterior doors.
9. Library materials will not be stored in the furnace room.
10. Staff will keep their work areas clean and hazard-free.

### Incident Reports

Incident reports must be filed out in all cases when it was necessary to call for outside help and in other situations in which the administration and staff should be informed because of possible repercussions. All incident reports will be reported to the director. A log of incident reports, patrons banned and problem patrons will be available for staff and police to review in case of repeat offenders. An incident report must include the following information:

1. How the injury occurred.
2. What was happening when the injury occurred.
3. Who else was present at the time of injury.
4. When and where the injury happened.
5. Other pertinent information in aid of investigating the incident.

### Emergency Response Procedures:

In case of an emergency dial 911. First aid supplies will be available.

## **Behavior in the Library Plainfield NH Public Libraries**

### **Policy Statement:**

The Trustees and staff seek to provide a comfortable environment for all library users, and to be stewards of the town's property in our care. We encourage people of all ages to visit the library. Those using the library and its resources have the right to expect a safe, comfortable environment that supports library services. We expect all library users to observe common courtesy toward other library users and library staff. Disruptive and discourteous behavior includes (but is not limited to) misuse of library property and actions that deliberately disturb others or prevent the legitimate use of the library and its resources.

### **Rules of Library Behavior**

- Adults are expected to control their children or remove them from the building. Unruly behavior by unattended children will result in notification of parent/guardian and request that the child be removed from the library.
- Patrons disturbing others may be asked to leave. In case of refusal, police will be notified.
- Persons repeatedly engaging in disruptive behavior will be banned from the library premises.
- Harassment of others, either verbally or by physical actions is prohibited. This includes any actions that library users or staff members perceive to be harassing.
- Threatening the safety of another person is prohibited.
- Use of tobacco in any form or illegal drugs is prohibited in the library.
- Theft of or damage to library property is prohibited and may result in appropriate prosecution and/or necessary restitution.

The level of action will be determined on a case-by-case basis and will be within the discretion of the Library Director or the Board of Trustees or the supervising staff member on duty. The library staff reserves the right to contact the Plainfield Police Department for assistance related to the dismissal of a patron.

Approved By:

Date:

## **Use of the Library by Children Plainfield NH Public Libraries**

The library invites and encourages children to use its facilities to develop a love of books, reading, and other media. Children are expected to behave in a manner that does not disturb the enjoyment of others nor jeopardize their safety or that of others. The library is not responsible for children left unattended on library property.

### Unattended Children:

1. Children under the age of eight must be in the immediate presence of an attending adult (see #5).
2. Children ages eight through eleven who are independent enough to use the resources for recreation, information and education must not be in the library unattended by an adult for more than two hours. The library and its grounds are not continuously monitored by staff. Parents/guardians leaving their children alone accept the resulting risks.
3. Library staff will assist lost or unattended children to find parents/guardians or an attending adult within the library building, or, if necessary, elsewhere. The library staff will make every reasonable effort to assist a lost child prior to closing and if at closing the parent/guardian has not been located – Police will be notified.
4. Children are expected to adhere to the same rules of conduct expected of adults. All library users are required to respect library property and to act in a manner appropriate to the use and function of a library, (See Behavior in the Library).
5. Unattended young people, ages 12-17, may use the library as adults.

Approved by:

Date:

Board of Trustees  
Plainfield Public Libraries  
**Approved**  
July 9, 2012  
Featured Library: Philip Read Memorial Library

Attending: Anita Brown, Kara Toms, Mark Pensgen, Hillary Sundell, Nancy Liston, Nancy Norwalk (Director of Philip Read Memorial Library).

Members of the Public: Dennis Girouard

Convened 7:09 after group picture taken on front steps.

A. Roll Call, Introduction of Nancy Liston, new Trustee, approval of agenda

1. Nancy Liston disclosed that she was also working at the Windsor Library, in case of conflict.
2. Approval of Minutes from June 11 meeting to be moved to July 16 meeting, still in draft form.

B. Public Comment;

1. Dennis G. had questions for Trustees pertaining to The Plainfacts dispersal and sales at PRML. Please see attachment. Response was that those decisions were made in Non-public meeting RSA 91-A:3,II ( a)

C. Announcement of Non-Public Meeting – RSA- A:3, II ( c)

D. Reports for PRML

1. Financial – Mark discussed the usefulness of the new computer, all data for both Libraries on computer. Discussion on how budget works between both Libraries, different budgets, different hours, payroll coming from town leads to faux discrepancies, because of time delay. Kara motions to accept, Anita second, motion was unanimous and carried. *Attachment*
2. Directors Report – Movie Night Starts Friday. Edgar Allen Poe programs discussion for October, very exciting. Automation going slowly but well, have 2 volunteers in place, one just starting, could use a fourth person, one is working 2 hours a week; one is working 3 – 4 hrs a week. Still have glitches, seems to be an ISBN # issue discussion on bringing a book from either library and see how it reads in the other, possible troubleshooting. Kara asked how many books have been done so far; Nancy N. said no report received this month. Nancy L. asked if there was a deadline, discussion on Meriden’s head start – because of no card catalog, there was a greater need to get into place. Kara moved to accept, Hillary to second. The Motion was unanimous and carried. *Attachment*
3. Facilities Report – Delay in the Valley News Notice, vote to accept the \$48,124.08 from the Friends will take place at the July 16 meeting. Discussion on whether “Friends” should pay the bill or if monies should be transferred to BOT to pay, who is authorizing work? Will be checked into. Anita spoke with Steve Hallerin to set up consult with Town Lawyer, Barry Shuster, about proceeding with arbitration with contractor as to the difference from original bid to current costs of materials and work. Mark moved to approve, Nancy L. to second, The Motion was unanimous and carried. *Attachment*

## E. PRML Library: Detailed Discussion

### 1. Director's Report –

- a. There are left over hours from Aides, discussion of hours – volunteers for automation. Howe's bibliographical data is the roadmap for data entry.
  - b. The Internet is receiving a lot of use, looking to increase bandwidth? Nancy N. has to reboot often, becoming a problem. BOT to contact Steve Hallerin to OK more bandwidth with Comcast. Nancy L. shared Windsor Public Library Internet Policy with Board.
  - c. Nancy N. has David Grobe estimate for handiwork for PRML - \$365.00. Kara said we should ask town for funds from the Library Repair Trust Fund. Mark moves to accept, Nancy L. to second. The motion was unanimous and carried.
  - d. Energy Audit – Still need to replace 2 lights in old section, attic insulation next? Discussion on getting bids. The deadline for "The Fuel Club" deadline coming up, Hillary to call around for bids.
  - e. Volunteer's lunch? Appreciation day for both libraries – Committee set up – Anita & Hillary and Kara will do the flyer.
  - f. Nancy Norwalk's e-mail of June 13<sup>th</sup> to go into Minutes. *Attachment*
  - g. Kudos on placements on signs for the 4<sup>th</sup> of July Parade
  - h. Recommendation for aide; discussion for Nonpublic Session.
2. Old Business – Kara will e-mail all changes of Policies to Kim, who has offered to help out with final in consistency and formatting.
  3. Behavior Policy – questions and discussion on cell phones. Mark moved to approve, Hillary to Second. The Motion was unanimous and carried.
  4. Safety Policy – Need a copy of Incident Report for August Meeting. Anita to move, Kara to second. The Motion was unanimous and carried
  5. Use of the Library by Children – discussion on highlighted phrase, Nancy Liston uncomfortable with verbiage. To be changed to "The library staff will make every reasonable effort to assist a lost child prior to closing and if at closing the parent/guardian has not been located – Police will be notified." Thanks to Dennis for the assist. This policy to be placed on August's agenda.

## F. New Business/ Announcements

1. To accept funding from The Friends or PRML for the egress: postponed until July 16<sup>th</sup> due to public notice time.
2. Anita moves to accept Grant of \$850 from Claremont Savings Bank, Mark says to have it on agenda. Postpone till July 16<sup>th</sup>.
3. Patron Visits
4. Marketing – website – ongoing discussion with M. Sutherland, need Facebook page for PRML. Nancy N. felt this would be a time consumer. How many people use Meriden Facebook?
5. Teagan Atwater to do e-mail education at PRML and will set up a Facebook page for the library.
6. PRML Steps – Nancy N. felt we need a Job meeting, Anita reported on Friend's meeting. The Building Committee is putting together a letter for fundraising Waiting on estimate for egress; need another estimated \$75,000. to finish, this includes bookcases etc. Dennis replied that we need approx. \$40,000. to gain occupancy permit – waiting on lawsuit. Changes in needs for design and layout for basement – Open Plan discussed at length. (Note: The downstairs design is currently all open, except for the meeting room.) Meeting spaces in both libraries should be complimentary not competing (I don't remember who said that but it was good)

Motion made to go into Nonpublic Session RSA - 91-A:3 (b), Anita moved, Kara seconded. The Motion was unanimous and carried.

Motion made to leave nonpublic session RSA 91-A:3,II (b) by Anita, seconded by Kara

Roll Call vote: Anita Brown – Yes  
Kara Toms – Yes  
Mark Pensgen – Yes  
Hillary Sundell – Yes  
Nancy Liston – Yes

Nancy Norwalk left meeting

Motion made to enter nonpublic session RSA 91-A:3,II ( c) by Anita, seconded by Kara

Roll Call vote: Anita Brown – Yes  
Kara Toms – Yes  
Mark Pensgen – Yes  
Hillary Sundell – Yes  
Nancy Liston – Yes

Motion made by Anita to return to public session, Nancy L. seconded.

Roll Call vote: Anita Brown – Yes  
Kara Toms – Yes  
Mark Pensgen – Yes  
Hillary Sundell – Yes  
Nancy Liston – Yes

Motion: PASSED

Public session reconvened at 11:10pm

Motion to seal the Nonpublic minutes, RSA 9-A:3:II ©, Anita seconded,

Roll Call vote: Anita Brown – Yes  
Kara Toms – Yes  
Mark Pensgen – Yes  
Hillary Sundell – Yes  
Nancy Liston – Yes

11:15pm - Kara moved to adjourn, Nancy L. to second, all agreed.

Library specific meetings: July 16, 2012 Meriden Library; 7:00pm

Next Regular Meeting: August 13, 2012; 7:00pm

Attachments:

Questions from Dennis G.

Financial Report

Facilities Report

Directors Report

Nancy Norwalk e-mail of June 13<sup>th</sup> - energy



## Philip Read Memorial Library 2012 Patron Visits

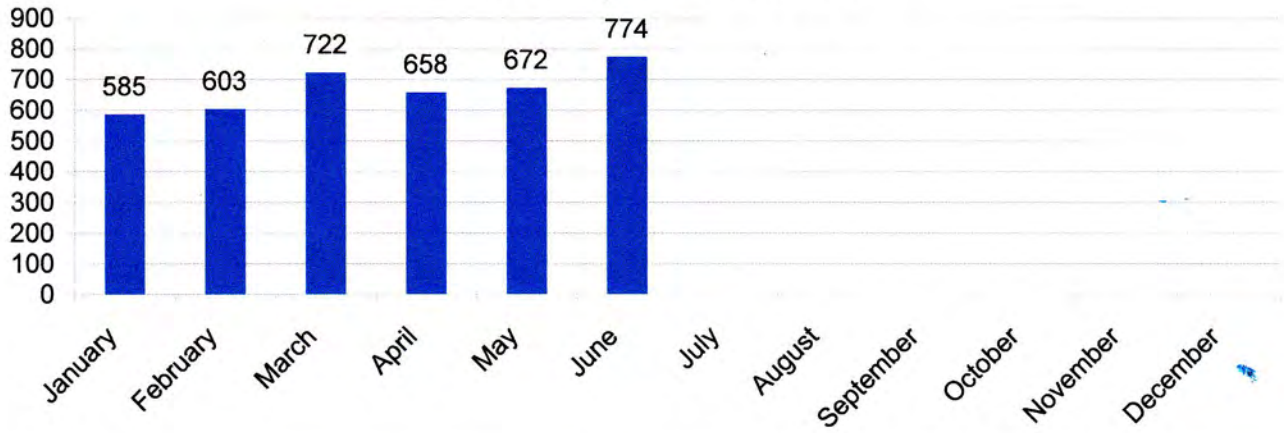

## Philip Read Memorial Library 2012 Circulation

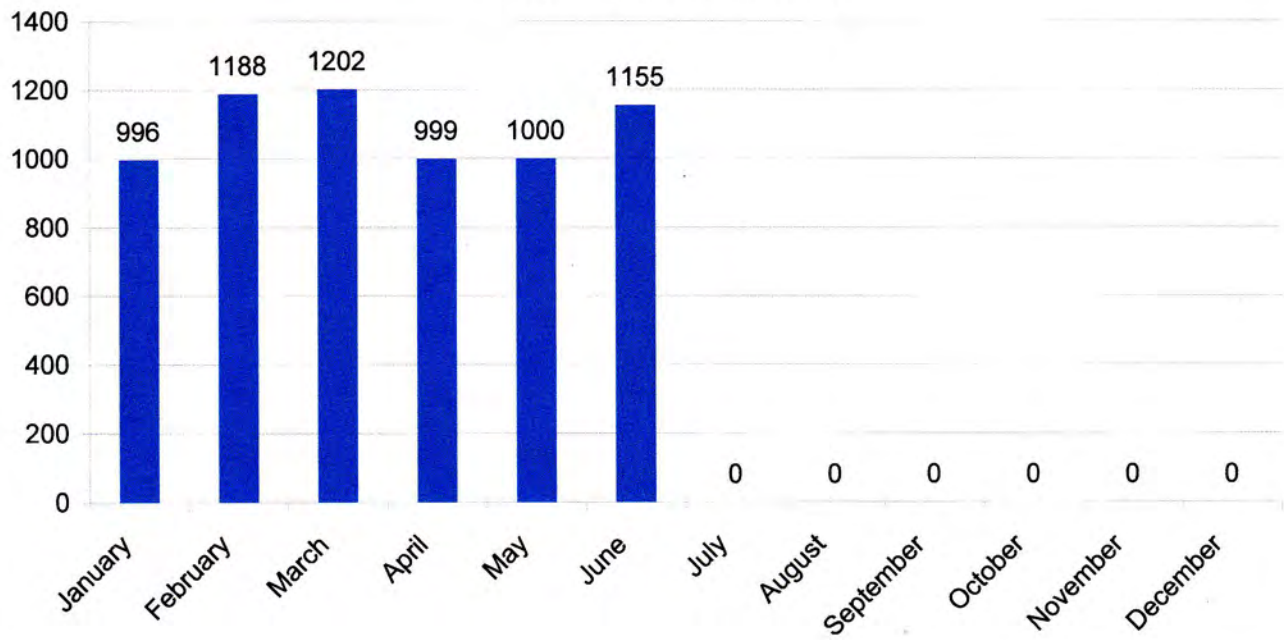

## **Behavior in the Library Plainfield NH Public Libraries**

### **Policy Statement:**

The Trustees and staff seek to provide a comfortable environment for all library users, and to be stewards of the town's property in our care. We encourage people of all ages to visit the library. Those using the library and its resources have the right to expect a safe, comfortable environment that supports library services. We expect all library users to observe common courtesy toward other library users and library staff. Disruptive and discourteous behavior includes (but is not limited to) misuse of library property and actions that deliberately disturb others or prevent the legitimate use of the library and its resources.

### **Rules of Library Behavior**

- Adults are expected to control their children or remove them from the building. Unruly behavior by unattended children will result in notification of parent/guardian and request that the child be removed from the library.
- Patrons disturbing others may be asked to leave. In case of refusal, police will be notified.
- Persons repeatedly engaging in disruptive behavior will be banned from the library premises.
- Harassment of others, either verbally or by physical actions is prohibited. This includes any actions that library users or staff members perceive to be harassing.
- Threatening the safety of another person is prohibited.
- Use of tobacco in any form or illegal drugs is prohibited in the library.
- Theft of or damage to library property is prohibited and may result in appropriate prosecution and/or necessary restitution.

The level of action will be determined on a case-by-case basis and will be within the discretion of the Library Director or the Board of Trustees or the supervising staff member on duty. The library staff reserves the right to contact the Plainfield Police Department for assistance related to the dismissal of a patron.

Approved By:

Date:

## **Safety Policy Plainfield NH Public Libraries**

### Objective:

The health and safety of Library staff, volunteers and patrons is very important. The Plainfield Public Libraries are members of Plainfield's Joint Loss Safety Committee. All staff shall make safety and the safety of their co-workers and patrons a priority. Staff shall conduct their daily tasks in a manner that is consistent with the philosophy and objectives of this policy. The policy is designed to comply with the standards of OSHA to endeavor to maintain a safe and injury / illness free workplace. A copy of OSHA Safety and Health Standard 1910 shall be available for staff use and reference. Enforcement of the Safety Policy is the responsibility of the Library Director.

### Compliance:

Compliance with the Safety Policy is required of all staff and applies to volunteers. Primary responsibility for enforcement of this policy is given to the Library Director. The Director shall:

1. Provide reasonable safe guards for all staff, volunteers and patrons.
2. Conduct health and safety inspections to help identify and eliminate unsafe working conditions or practices, to control health hazards and to comply fully with Safety and Health Standards.
3. Make staff aware of health and safety practices.
4. Develop, update and enforce health and safety rules.
5. Require that all staff and volunteers cooperate with these regulations.
6. Investigate promptly and thoroughly, accidents or incidents to determine the cause and act to prevent any recurrence.
7. Regularly evaluate all areas of safety & make recommendations to the Trustees.

### Staff and volunteers shall:

1. Report all unsafe conditions and practices immediately to the Library Director.
2. Use common sense and care to prevent injury to themselves and others.
3. Keep aisles and exits clear at all times.
4. Immediately report any incidents or injuries to the Director.
5. Be aware of the location of the first aid kit.
6. Be aware of the location of fire extinguishers.
7. Use caution on icy walkways. Sprinkle de-icer on steps.
8. Staff working in the library after closing hours shall lock exterior doors.
9. Library materials will not be stored in the furnace room.
10. Staff will keep their work areas clean and hazard-free.

### Incident Reports

Incident reports must be filed out in all cases when it was necessary to call for outside help and in other situations in which the administration and staff should be informed because of possible repercussions. All incident reports will be reported to the director. A log of incident reports, patrons banned and problem patrons will be available for staff and police to review in case of repeat offenders. An incident report must include the following information:

1. How the injury occurred.
2. What was happening when the injury occurred.
3. Who else was present at the time of injury.
4. When and where the injury happened.
5. Other pertinent information in aid of investigating the incident.

### Emergency Response Procedures:

In case of an emergency dial 911. First aid supplies will be available.

## **Use of the Library by Children Plainfield NH Public Libraries**

The library invites and encourages children to use its facilities to develop a love of books, reading, and other media. Children are expected to behave in a manner that does not disturb the enjoyment of others nor jeopardize their safety or that of others. The library is not responsible for children left unattended on library property.

### Unattended Children:

1. Children under the age of eight must be in the immediate presence of an attending adult (see #5).
2. Children ages eight through eleven who are independent enough to use the resources for recreation, information and education must not be in the library unattended by an adult for more than two hours. The library and its grounds are not continuously monitored by staff. Parents/guardians leaving their children alone accept the resulting risks.
3. Library staff will assist lost or unattended children to find parents/guardians or an attending adult within the library building, or, if necessary, elsewhere. The library staff will make every reasonable effort to assist a lost child prior to closing and if at closing the parent/guardian has not been located – Police will be notified.
4. Children are expected to adhere to the same rules of conduct expected of adults. All library users are required to respect library property and to act in a manner appropriate to the use and function of a library, (See Behavior in the Library).
5. Unattended young people, ages 12-17, may use the library as adults.

Approved by:

Date:

Board of Trustees  
Plainfield Public Libraries  
Minutes  
June 11, 2012  
Regular Meeting

Attending: Anita Brown, Kara Toms, Mark Pensgen, Hillary Sundell, Nancy Norwalk (Director of Philip Read Memorial Library), Mary King (Director of Meriden Library)  
Members of the Public: Judy Durant, Lee Abrahamson, Pam Abrahamson, Anna may Chapman, Dennis Girouard

Convened 7:11pm

- A. Agenda approved
- B. Public Comment – none
- C. Approval of May Minutes with Nancy Norwalk’s changes.  
Kara to move, Hillary seconded as amended. Motion passed.
- D. Correspondence
  - 1. Donation to PRML \$100. From Hanover Garden Club for Gardening Books or Nature. Mark moved to Accept, Kara seconded, Motion passed. Donation approved.
  - 2. ARC Mechanical Donation Letter (See Attachment). We need to formally thank ARC for AC system. The total system was \$9,150. We paid \$ 4,600. So the total donation of labor by ARC was \$4,550. Donation to be accepted, Mark moved Hillary to second, all approve.
  - 3. Discussed ways to notify the public when warranted; Facebook, Plainfacts, Valley News
- E. Peter Appleton to be a paid employee discussion – result – no.
- F. Non-Public session announcement made, and accepted at 9pm.
- G. Discussion on Senior luncheon.

Reports

- A. Mary is adding the popular videos, and adult fiction first into the automated system, 1125 records already done. Helps knowing what is in Howe Library. Have done some of the records downstairs but not much yet. Laurie being trained. There are 3 substitutes on the list. Director’s Reports attached (3)
- B. Nancy said that Marv (Clif) storyteller was very successful. The ISBN #'s do not seem to be working, there are glitches. Kara asked how many volunteers needed? 4 would be good, but can use 3. Discussion on replacement for Diane, Suellen would like the position, but waiting for school to be out. Mary suggested language change to “recruit” All agreed. Subject to July’s meeting to approve Suellen at 6 hours a week. Kara moved to approve, Anita seconded. Director’s reports attached.
- C. Financials  
Mark – Al’s check was rewritten to reflect his raise. Mark to write a check to divide the cost of the seminar between the Libraries.

#### D. Work Groups

1. Financial work group report – Kara moved to fund new computer for accounting. Discussion on which library monies to come from and will be divided equally. Hillary moved to approve, Anita seconded. Kara moved to accept the financial reports, Anita seconded, motion passed.
2. Facilities – Meriden – discussion on Shed, circulation desk, space planner. (See attached report) Motion to accept Thom Lappin bid for work at Meriden Library, Anita moved to accept bid with caveat for future, Mark moved and Anita seconded. All accepted.  
PRML – Kara asked Nancy to find out drawbacks for Power solution, answer attached. Mark stated that the BOT needs to accept donations from Friends – at an est. of \$48,000. Need to have a public meeting after announcing in a public forum, Valley News. Nancy has issues with the sand barrel.
3. Revisions discussed on Policies for Behavior in the Library – delete “alcohol from 6<sup>th</sup> bullet. Move #5 closer to #1 on Safety Policies. Revisions to be sent to Kara.

Anita moved to go into RSA 91-A:3,II (a)

Hillary seconded, all agree – Mark, Kara, Anita and Hillary

Anita moved to vote out of RSA 91-A:3,II (a), Mark seconded, Anita, Kara, Mark and Hillary. Accepted.

Adjournment at 10:40pm

Library Specific Meetings: July 9; PRML; 7:00pm  
July 16, ML; 7:00pm

Next Regular Meeting: August 6, 2012; PRML; 7:15pm

Attachments; 12 pieces

Meriden Directors Report – 3

PRML Directors Report

PPL Facilities Report

ARC Mechanical Bid

Policys – 3

PPL Financial report

Financial Working Group report.

Residential Power e-mail

**DIRECTOR'S REPORT**  
**PHILIP READ MEMORIAL LIBRARY**  
**JUNE 2012**

1. Donation - The library received a \$100 donation from the Hanover Garden Club, designated for nature or gardening books.
2. Maintenance - David Grobe has been in to discuss the maintenance list and do a walk-around. He will send an estimate and suggestions shortly.
3. CLiF Presentation – The presentation at the school went very well. Everyone enjoyed the storyteller. Patrons have been checking out the new books and are raving about the titles. The daycare program at the library was also very successful. The daycare providers especially appreciated being given a selection of books for their daycare. Children were able to choose two books each to keep. Only two daycare groups were able to come; one other was scheduled to attend but cancelled at the last minute. I delivered books to the group that was unable to come.
4. Phone issue – Bringing you up-to-date on an odd issue that most of you are probably unaware of. Last spring, while checking with the phone company on something, Bernadina, by chance, discovered that the phone company had the wrong address listed for the back-up fire alarm phone. It was an address on Stage Road, which probably was the address of the previous holder of that phone number. She was unable to convince the phone company to correct the problem. I have been following up on it with the phone company and have finally convinced them that the library is not on Stage Road. The representative I talked to has issued the change orders.
5. Automation – The cataloguing process is moving along steadily. One volunteer has continued to work regularly. One new volunteer has been trained and will work weekly. It appears that one volunteer who has been trained is not going to work out. However, someone who I believe will be reliable has volunteered and will be scheduled for training. We have been a little frustrated by some glitches in the system which held us up for a couple of weeks. There were two issues caused by some changes/corrections that Evergreen had made in our permissions, but that seems to be solved now.

Submitted by  
Nancy Norwalk, Director

## Financial Working Group

May 2012

Mark Pensgen

Hillary Sundell

- Mark & Hillary met at PRML on May 23<sup>rd</sup>. Discussed Mark's intensive work on the Meriden's accounts to this point. The overview of most entries dating back to 1990 seem to be fine, although with very little notating for allocating money for specific gifts.
- Mark met with Sarah Governo on June 6, 2012. She thought the approach was good and agreed with the analysis. We are now in the process of scheduling a meeting with Terry Knowles to complete this phase of the process.
- The need for a separate computer for the libraries finances is evident. Mark has found a capable laptop at Wincycle which can be acquired for \$225 which represents a 25% discount available to a non-profit entity.
- Mark and Hillary attended financial sessions at the recent New Hampshire Trustees Association meeting in Concord. There were 2 different presentations made by Terry Knowles which were helpful to increase our overall level of understanding of the rules governing financial matters. We discussed directly with Ms. Knowles the payment of the air conditioner for the Meriden Library and learned that the payment from private funds was appropriate, this is an item which should have been included in the yearly budget (not withstanding the fact that this offer from Arc Mechanical was not known during the budget season). This understanding will inform our budgeting process for 2013.



Meriden Library  
Director's Report  
May 2012

May statistics are attached.

Two additional volunteers were trained to catalog books in Evergreen bringing us to four active volunteers for this project. I will not recruit additional volunteers for cataloging while we work on a schedule for this group. I am seeking more volunteers for other library tasks.

Through the Beupre Community Service Day four students from the Plainfield Elementary School volunteered at the Meriden Library on Friday, May 18. The students helped to organize and label books in the children's room.

I attended the Librarians of the Upper Valley Cooperative meeting on May 21. The meeting was held at the Norwich, VT Public Library. The program focused on social networking for libraries particularly the use of Facebook in marketing your library.

Terri Crane was trained as a substitute library aide. Terri will be added to the substitute list that covers staff absences. With summer vacations scheduled for all staff, I felt that we needed additional coverage particularly for evening and Saturday hours.



**New Hampshire**  
603-444-3440  
30 Cottage Street, Littleton  
603-443-6111  
1 Mechanic Street, Lebanon

**Vermont**  
802-222-9255  
229 Depot Street, Bradford  
arc@arcmech.com  
www.arcmech.com

**Jody Perkins**  
President/Service Manager  
802-222-9255  
802-222-5481 Fax  
jperkins@arcmech.com

February 28, 2012

Mary King, Kara Toms, Mark Pensgen  
Meriden Library  
22 Bean Road  
Meriden, NH 03770

meridenlibrary@comcast.net

**PROPOSAL# SQ12-022**

Job Name & Location

Job Name: Air Conditioning

Job Location: First Floor

**Specifications**

Mary, Kara and Mark,

Now that spring is approaching I am turning my attention back to this very important part of our community, the Meriden Library. The growth of the Meriden Library over the past few years has been impressive and important to not only the community but to my family. Having the ability to help out communities is also important to ARC Mechanical Contractors and with this proposal I hope we can make this happen. ARC Mechanical will supply all the labor to install this system at no charge and we will supply the material at a reduced rate to the Meriden Library. In my opinion this will only enhance what has been happening at the library. This system will give our community members a nice place to cool down on a hot summer day and enjoy the books the library has to offer. This heat pump system not only cools but it also has the capability of heating, which will in turn will significantly save on the library's oil bill.

Best regards,

Jody

We propose the following scope of work:

- Install two Mitsubishi Electric MSZGE18NA indoor heat pump evaporators.
- Install one Mitsubishi Electric MXZ4B36NA multi zone heat pump condenser.
- Install Mitsubishi line hide pipe covering.
- Install refrigeration and drain piping.
- Pressurize the system and test for leaks.
- Evacuate the system to 500 microns.
- Start up and test system operation.

Note:

The Library will also be responsible for the electrical and building permit.

**Budget Price:**

Four Thousand, Three Hundred Fifty and 00/100 Dollars

\$ 4,350.00

**Notes**

Regular price:

Total \$ 8,700.00

Y/N

\_\_\_\_\_  
\_\_\_\_\_  
\_\_\_\_\_  
\_\_\_\_\_  
\_\_\_\_\_  
\_\_\_\_\_  
\_\_\_\_\_  
\_\_\_\_\_  
\_\_\_\_\_

**Respectfully Submitted by**  
ARC Mechanical Contractors, Inc.

  
\_\_\_\_\_  
Jody Perkins, President/Service Manager

**Accepted**

The specifications, terms and conditions outlined are satisfactory and are hereby accepted. You are authorized to do the work as specified. Payment will be made as outlined below.

\_\_\_\_\_  
**Signature**

\_\_\_\_\_  
**Date**

Note: This proposal may be withdrawn by us if not accepted within 30 days.

\_\_\_\_\_  
**Print Name & Title**

**Exclusions**

- |  |   |                                |
|--|---|--------------------------------|
| <input type="checkbox"/> Lp gas tanks, primary piping and regulators.      | <input type="checkbox"/> Performance and payment bond premiums.                                 | <input type="checkbox"/> Other |
| <input type="checkbox"/> Services 5' beyond the building.                  | <input type="checkbox"/> Cutting, patching, core drilling, painting.                            | <input type="checkbox"/> Other |
| <input checked="" type="checkbox"/> Premium time labor.                    | <input type="checkbox"/> Fire protection systems & duct smoke detectors.                        | <input type="checkbox"/> Other |
| <input type="checkbox"/> Asbestos abatement (if required).                 | <input type="checkbox"/> Line voltage electrical wiring & loose disconnects.                    | <input type="checkbox"/> Other |
| <input type="checkbox"/> Temporary heat and plumbing.                      | <input type="checkbox"/> Toilet room accessories (grab bars, mirrors, dispensers, etc.).        | <input type="checkbox"/> Other |
| <input type="checkbox"/> Digging, backfilling & trench bedding.            | <input checked="" type="checkbox"/> Repairs/modifications to systems beyond this scope of work. | <input type="checkbox"/> Other |
| <input checked="" type="checkbox"/> Permits and permit fees (if required). | <input type="checkbox"/> Concrete equipment pads and pad seismic bracing.                       | <input type="checkbox"/> Other |

**Payment Terms**

- Invoices on account (pending credit approval) to be submitted by the 25th of each month based on work completed and materials purchased.
- Due upon receipt - 1% finance charge (allowed by law) on all invoices 30 days past due.
- We accept Mastercard, Visa and American Express.
- Financing available. Contact ARC Mechanical Contractors, Inc. for information.
- In the event that ARC Mechanical Contractors, Inc. takes any collection action to collect on any balance due which is 30 days or older, the Customer shall pay all costs and attorneys fees associated with any such collection effort.

**Limited Warranty**

All products provided and installed by ARC Mechanical Contractors, Inc are warranted to be free from defects in material and workmanship for a period of one year from the original installation unless otherwise noted and unless a product manufacturer's warranty is less than one year in which case the Limited Warranty given herein shall extend only for that period of time covered by the applicable manufacturer's warranty. This Limited Warranty is limited to parts and labor for repair or replacement of defective parts only. This Limited Warranty does not cover consequential damages, including but not limited to loss of income or profits and ARC Mechanical Contractors, Inc shall not be responsible for any such consequential damages. To the extent that a warranty issued by a product manufacturer in some cases may extend beyond the one year period, this Limited Warranty shall extend for the full period of the manufacturer's warranty on the applicable piece of equipment. Except as stated herein, THERE ARE NO OTHER WARRANTIES, EITHER EXPRESS OR IMPLIED.

## Meriden Library Stats

### Visits

	January	February	March	April	May	June	July	August	Sept	Oct	Nov	December	Total
<b>Patron Visits</b>													
Adults	316	348	434	316	374								1788
Young Adults	6	8	14	15	17								60
Children	52	97	84	106	80								419
<b>Total</b>	374	453	532	437	471							0	2267

### Circulation

	January	February	March	April	May	June	July	August	Sept	October	November	December	Total
<b>Adults</b>													
Fiction	185	144	181	171	154								185
Non-Fiction	45	48	66	49	51								259
<b>Children</b>													
Fiction	204	238	244	196	242								1124
Non-Fiction	37	66	59	55	33								250
DVD	63	88	68	66	63								348
Magazine	22	20	13	12	25								92
ILL incoming	15	38	43	62	32								0
Audio	22	25	30	16	27								120
<b>Total</b>	593	667	704	627	627								3218
Volunteer Hours		5.5	9.5	10	30								55
New Patrons													

### Programs

	January	February	March	April	May	June	July	August	Sept	October	November	December	Total
<b>Story Time/Play Group</b>	4	2	2	2	1								11
Child	9	4	5	5	5								28
Adult	7	2	3	4	3								19
<b>Book Groups</b>	2	1	2	1	2								
Tuesday	6	6	7	8	9								36
M/D	10		8		10								28
<b>Special Programs</b>		2	1	1									4
Children		13	11	10									34
Young Adult													0
Adult		5	42	6									53
<b>Genealogy</b>	3	1	2		2								8
<b>Fiber Art</b>	5	2											7
<b>Total Attendance</b>	40	31	78	33	29								211
<b>Total Programs</b>	8	7	6	5		0							26

**Meriden Library**  
**Profit & Loss Budget vs. Actual**  
 January 1 through June 6, 2012

9:24 AM  
 06/06/2012  
 Accrual Basis

	<u>Jan 1 - Jun 6, 12</u>	<u>Budget</u>	<u>% of Budget</u>
<b>Ordinary Income/Expense</b>			
<b>Income</b>			
Town Appropriation	16,792.03	42,376.00	39.63%
Town Approp - FICA	773.94	2,112.00	36.65%
Trust Funds	425.00	850.00	50.0%
Gifts	905.56	50.00	1,811.12%
Book Fines/Copier	23.50	100.00	23.5%
Book Sales	30.00	0.00	100.0%
Interest Income			
Interest - Savings	19.50	10.00	195.0%
Interest Checking	1.14	0.00	100.0%
Total Interest Income	20.64	10.00	206.4%
Misc Income	27.00	300.00	9.0%
<b>Total Income</b>	<b>18,997.67</b>	<b>45,798.00</b>	<b>41.48%</b>
<b>Expense</b>			
Salaries	10,117.03	27,611.00	36.64%
FICA	773.94	2,112.00	36.65%
Sick Pay	0.00	285.00	0.0%
Library Materials			
Audio/Visual	561.28	500.00	112.26%
Books & magazines	2,028.86	5,000.00	40.58%
Total Library Materials	2,590.14	5,500.00	47.09%
Telephone	211.39	540.00	39.15%
Electricity	578.50	1,000.00	57.85%
Fuel	2,083.64	3,200.00	65.11%
Water/Sewer	200.00	500.00	40.0%
Supplies	346.23	800.00	43.28%
Postage	64.10	300.00	21.37%
Professional Activities	96.28	450.00	21.4%
Programs	150.35	400.00	37.59%
Furniture/Equipment	0.00	100.00	0.0%
Maintenance	500.00	1,400.00	35.71%
Automation	0.00	1,000.00	0.0%
Computer	185.96	500.00	37.19%
Misc Expense	11.22	100.00	11.22%
<b>Total Expense</b>	<b>17,908.78</b>	<b>45,798.00</b>	<b>39.1%</b>
<b>Net Ordinary Income</b>	<b>1,088.89</b>	<b>0.00</b>	<b>100.0%</b>
<b>Other Income/Expense</b>			
Other Income			
Transfer from Building Fund	4,600.00	0.00	100.0%
Other Expense			
Building Capital Improvements	4,600.00	0.00	100.0%
Total Other Expense	0.00	0.00	0.0%
<b>Net Other Income</b>	<b>0.00</b>	<b>0.00</b>	<b>0.0%</b>
<b>Net Income</b>	<b>1,088.89</b>	<b>0.00</b>	<b>100.0%</b>

PRML

	<u>Jan 1 - Jun 4, 12</u>	<u>Budget</u>	<u>% of Budget</u>
<b>Income</b>			
Encumbered Funds 2011	2,404.38	3,194.05	75.28%
Town Appropriation			
Appropriation-Operations	12,225.00	30,330.00	40.31%
Appropriation-Salary	12,811.98	33,749.00	37.96%
FICA	759.94	2,582.00	29.43%
Town Appropriation - Other	0.00	0.00	0.0%
<b>Total Town Appropriation</b>	<b>25,796.92</b>	<b>66,661.00</b>	<b>38.7%</b>
Trust Fund Income	1,200.00	2,400.00	50.0%
Fines	312.98	100.00	312.98%
Gifts	160.00	50.00	320.0%
Grants	700.00	700.00	100.0%
Misc Income	62.47	300.00	20.82%
<b>Total Income</b>	<b>30,636.75</b>	<b>73,405.05</b>	<b>41.74%</b>
<b>Expense</b>			
Encumbered Funds	3,014.90	3,194.05	94.39%
Payroll			
Salaries	12,811.98	34,749.00	36.87%
FICA	759.94	2,624.00	28.96%
Payroll - Other	0.00	0.00	0.0%
<b>Total Payroll</b>	<b>13,571.92</b>	<b>37,373.00</b>	<b>36.32%</b>
Library Materials			
Books and Magazines	2,673.83	8,000.00	33.42%
Audio Visual Materials	583.11	1,200.00	48.59%
Library Materials - Other	0.00	0.00	0.0%
<b>Total Library Materials</b>	<b>3,256.94</b>	<b>9,200.00</b>	<b>35.4%</b>
Catalog Services/Automation	370.90	1,500.00	24.73%
Supplies	791.50	1,500.00	52.77%
Postage	104.00	250.00	41.6%
Programs	138.76	600.00	23.13%
Professional Activities	460.15	450.00	102.26%
Oil	3,824.84	7,500.00	51.0%
Electricity	1,156.79	3,400.00	34.02%
Telephone	517.28	1,080.00	47.9%
Water	95.50	300.00	31.83%
Maintenance			
Maintenance-General Expenses	511.44	3,000.00	17.05%
Elevator	584.06	1,700.00	34.36%
Maintenance - Other	0.00	0.00	0.0%
<b>Total Maintenance</b>	<b>1,095.50</b>	<b>4,700.00</b>	<b>23.31%</b>
Furnishings and Equipment	43.99	500.00	8.8%
Computer Hardware and Software	100.00	1,000.00	10.0%
Miscellaneous Expense			
Grants	0.00	700.00	0.0%
Miscellaneous Expense - Other	0.00	200.00	0.0%
<b>Total Miscellaneous Expense</b>	<b>0.00</b>	<b>900.00</b>	<b>0.0%</b>
<b>Total Expense</b>	<b>28,542.97</b>	<b>73,447.05</b>	<b>38.86%</b>
<b>Net Income</b>	<b>2,093.78</b>	<b>-42.00</b>	<b>-4,985.19%</b>



Hillary Sundell <hth.sundell@gmail.com>

---

**residential power-electricity**

1 message

---

Philip Read Memorial Library <director@plainfieldnhlibrary.org>

Wed, Jun 13, 2012 at 6:28 PM

To: "Anita K. Brown" <Anita.K.Brown@dartmouth.edu>, Kara&Dan <tomsbarnett@tds.net>, Mark Pensgen <markr.pensgen@gmail.com>, liston.nancy@gmail.com, Hillary Sundell <hth.sundell@gmail.com>, Meriden Library <meridenlibrary@comcast.net>

Hi,

I talked to Allan Ferguson at the Energy Comm. meeting last night.

The energy/electricity cost savings proposal is not feasible at this time. Because of the competition from these alternative companies, the following has happened:

National Grid – they have lowered their prices.

PSNH – they have increased their delivery charges wiping out any cost savings.

Nancy

**Board of Trustees  
Plainfield Town Libraries  
Minutes  
May 7, 2012 7:00PM  
Featured Library: Meriden Library**

Attending: Kara Toms, Mark Pensgen, Hillary Sundell, Mary King (Director of Meriden Library)

Absent: Anita Brown

Members of the public: Dennis Girouard, Gordon & Fern Wilder, Richard Rogers, Maria Guzman, Laura Dintino, Susan Russo, Bev Widger, Susan Nugent

Convened 7:05pm

A. Minutes from April Meeting were approved.

B. Correspondence – None reported

C. Public Comments

Mark read an email sent by Maria Guzman. Mark covered that most of her questions are in process of being answered/or have already been answered. Kara spoke of this as well.

Gordon Wilder had questions regarding funding of the ARC proposal. Mark mentioned that the Vanguard account was the building account and was all private donations. We also had accepted this bid from ARC at the last meeting as being financially prudent at this time. Kara described the uncomfortable heat in the building during the summer. Susan Nugent commented that the same system at the school with its heat transfer was very economical and would prove very valuable in the future as a cost saving in both seasons. Dennis asked if we knew which donations were earmarked for specific purposes. Mark replied that as to the building fund, there were no earmarks that he could find in his due diligence research.

Bev Widger asked how close we were to going to Terry Knowles with our discoveries and plan. Mark then relayed his thoughts of meeting with two outside citizens, Bev Widger & Sara Governo, to go over all of the statements and financials that have thus far been gathered by Mark, followed by an appointment with Terry Knowles, which Mark thought would be the greatest time consumer in this process.

As time was running short, it was recommended that we read Diane's letter next public meeting (May 14, 2012) as we did not have the complete letter to read to the public as well, and was agreed to.

D. The Meriden Budget was handed out. Mark pointed out the salaries and how there is a time delay because of numbers arriving from the Town.



## E. Meriden Library

### 1. Facilities Report

Kara highlighted the condition of the basement egress and the trim around windows, with a suggestion that we look for a bid for all trim. Kara made a MOTION to requests bids for repairing/painting all trim. Mark moved and Hillary seconded.

The motion was unanimous and carried.

### 2. Director's Report

Discussion as to timeliness of the Automation system & Circulation desk being completed at the same time; end of summer is current outlook for both.

Mark spoke with Pam at Howe Library as to the timeline of other libraries going live and would we affect this. The response was that it would not affect their progress. Mary attended a conference with smaller libraries in mind. Friends of The Meriden Library held their first fundraiser, plant sale.

MOTION to accept the Director's Report. Kara moved and it was seconded by Mark & Hillary. The motion was unanimous and carried.

### 3. Other

Summer reading program: Mary's take from patrons is that afternoons for programs are not very good and that evening programs would be better attended. Mary has engaged a storyteller to perform at the School on July 12 at 6pm and this is funded by a grant from the State. Mary is also looking into a NH. Science (mobile) coming for a demonstration this summer. She is also scheduling some night sky sessions hoping to engage patrons with telescopes to join in.

Discussion on downloadable audios: A presentation on the NH Downloadable Consortium is planned for June to help patrons learn how to access audio books and download them to their own devices. Mary mentioned discussion from other librarians regarding the risks of libraries loaning electronic devices.

Mary asked the Board as to the status of the strategic future and what did we foresee as to ADA compliance. Thoughts on hiring a space planner or architect; basement not feasible for ADA; what cost to fix basement egress if we foresee the addition being built in the future?

Dennis suggested that we get two quotes – one on revamping existing building and the cost of a larger addition. Mark suggested creating a building subcommittee "Exploratory Building Research" for this. Kara would like to see a timeline– perhaps something for Town meeting. **This item to be placed on Agenda for June Meeting.**

## F. Old Business – ARC quote

1. Discussion on the additional monies for the control system for the air conditioner. The purpose is to sync the two units allowing for overall control. ARC originally wanted

\$450 – but brought the cost down to \$250 for a decrease to add to the original bid (\$4,350) at a total of \$4,600.

MOTION to accept the increase for the ARC bid was moved by Kara and seconded by Mark. The motion was unanimous and carried.

Motion was made to use monies from Building Account (Vanguard) to fund the full amount. Mark to investigate/contact this account to have monies appropriated for this. MOTION made by Kara, seconded by Mark. The motion was unanimous and carried.

G. Announcements

1. With Kim's resignation from the board, discussion on finding a new trustee to replace Kim, Nancy Norwalk had mentioned Nancy Liston and it was thought that we table this for next meeting in hopes that we might have a couple more candidates for the position to submit to the Selectmen next week.
2. Diane's letter to be read next week at the PRML meeting in its entirety.
3. The need to get the Director's reviews done was mentioned by Kara, and agreed by all.
4. The amount of work and the little amount of time to do it in was brought up by Mark, suggestions of possible alternate or additional trustees was discussed. Dennis mentioned that it would take at least a year as we would need to bring it before the voters. Hillary to look into the feasibility of and how to go about setting up two additional trustees.

Adjourn: 9:10pm (?)

Next Meeting: May 14 - 7pm; Plainfield Library & June 11- 7pm

BOARD OF TRUSTEES, PLAINFIELD TOWN LIBRARIES

April 9, 2012; 6:30 PM – Philip Read Memorial Library

*Draft Minutes*

Attending: Anita Brown, Mark Pensgen, Kara Toms, Kimberly Moss, Hillary Sundell, Nancy Norwalk (Director, PRML), Mary King (Director, Meriden Library)

Members of the public: Dennis Girouard

Call to Order—Trustees 6:35p.m.

A. Election of Officers

MOTION— Kara moved and Anita seconded that the offices be held as follows:

Anita-Chair  
Kara-Vice Chair  
Mark-Treasurer  
Kim-Secretary  
Hillary-Corresponding Secretary

The motion was unanimous and carried.

B. Selection of Working Groups

After discussion, trustees were assigned to working groups as follows:

Human Resources-Anita  
Technology-Kim and Mark  
Financial-Hillary and Mark  
Facilities-Kara and Anita  
Marketing-Kara  
Policies-Hillary

C. Other Responsibilities

After discussion, additional trustee responsibilities were assigned as follows:

Trustee Liaison to Friends' Groups-Mark, Anita  
Trustee Liaison to Building Committees-Anita, Kara

D. NHLTA 2012 Spring Conference

The NHLTA 2012 Spring Conference will be in Bedford, NH on May 21, 2012. The sessions include:

Strategic Planning: Vision and Action  
Making the Ask: The Art of Fearless Fundraising  
Facebook, Twitter & Beyond  
Building the Library of the Future  
Guarding the Guardians  
Resolving Conflicts for Optimum Outcomes  
Supporting Non-Profit Organizations for Libraries  
It's All in the Numbers  
Succession Planning: Future Perfect Staff

Marketing Strategies for Libraries  
It's the Law: Employment Law and Personnel Policies  
The Other Money

(Further details on each session can be found at  
[http://www.nhlta.com/pdf\\_documents/Conf\\_Flyer\\_2012.pdf](http://www.nhlta.com/pdf_documents/Conf_Flyer_2012.pdf) )

It was agreed that all the trustees should attend. We discussed who would attend which sessions.

#### E. Discussion of Budget and Accounting Structure

Mark suggested a long-term plan to have Quickbooks for both libraries on one computer designated for that function. The long-term goal would be to have one checking account for the town appropriation and keep the savings accounts for each library to be used for donations and gifts. In the short-term we need to change signators on the checking accounts for each library. As the financial working group, Hillary and Mark will meet and come up with a plan for moving to the one checking account once the funding issue with Meriden Library has been resolved. They will present their suggestions to the remainder of the board at the June meeting.

We will add Hillary and Mark to the Mascoma Savings Bank (Philip Read checking account) account, keep Anita on it and take Bernadina off of the account.

At the Claremont Savings Bank (Meriden Library checking account) we will add Hillary and leave Kara and Mark as signators.

#### F. Discussion of Schedule and Structure of Meetings

Call to Order: Trustees and Directors 7:16 p.m.

#### Public Comment

Dennis wanted to clarify that he and Diane did not work together that he did not know about Diane's 2/13 letter. Dennis also wanted us to know that he has never accused any of us of being immoral, unethical, malicious. He does not feel that he has personally attacked anyone on the board. He also stated that he is not against the unified board. He has never heard Diane speak of being against the unified board in a public setting either. Dennis felt after the Selectboard meeting that the funding issue was being resolved. Dennis asked that the Trustees "come out publicly" and make a statement in support of Diane.

#### A. Approval of minutes of previous meetings

March 5:

MOTION— Kara moved and Kim seconded that the minutes be approved as submitted pending any changes from Terry Knowles. The motion was unanimous and carried.

March 19:

MOTION— Hillary moved and Mark seconded that the public session minutes of 3/12/12 be approved as submitted. The motion was unanimous and carried.

MOTION— Anita moved and Mark seconded that the sealed non-public session minutes be approved as submitted. The motion was unanimous and carried.

April 3:

MOTION— Mark moved and Hillary seconded that the sealed non-public session minutes be approved as submitted. The motion was unanimous and carried.

B. Correspondence

Constance Zea has requested that the funds given in memory of Howard be restricted to “memorial books”. Mary will clarify this further.

MOTION— Kara moved and Anita seconded that the donations received between February 25-March 20 to the Meriden Library in memory of Howard Zea in the amount of \$300 be accepted. The motion was unanimous and carried.

C. Non-public session announcement (RSA 91-A:3, IIa)—There will be a non-public session with the Board only.

Reports

A. Financial

Mark will send out financial reports for both libraries.

Mark requested the appropriation for both libraries. The full amount was deposited into the PRML account as PRML had pressing bills. Mark will write a check from the PRML checking account to Meriden Library for the amount of the appropriation budgeted for Meriden Library.

B. Library Directors

1) Meriden

Mary found out today that Meriden did receive the funding for a performance for the 2012 Summer Reading Program through the “Kids, Books and the Arts” grant to the NH State Library.

Mary feels she still needs more committed volunteers to do the cataloging of books for automation.

2) PRML

Nancy has assembled a Building Committee in preparation with construction resuming on the basement. The committee will consist of Rob Drye, Dennis Girouard, Des Hudson, Bernadina Webber, Dick Rogers, David Grobe and Nancy. Anita will serve as the Trustee Liaison for the building committee.

There is a problem with email at the library. The town is having the same issue. Mike Sutherland is working to resolve it and showed Nancy how to find the missing emails. At this point neither Mike nor the webhost have been able to figure out why the emails are being sent to spam.

Mike Sutherland and George Adams have been discussing changes to the PRML website.

C. Working Groups

1) Technology—Nancy is training volunteers on cataloging. She has 4 volunteers for approximately 4-6 hours/week, but not on a regular schedule yet.

2) Facilities

Kara will follow up with Bernadina re: signing up for [www.residentpower.com](http://www.residentpower.com).

Anita and Kara will schedule the spring walk-about with the Library Director for each library.

The window washing bid from Jeff Hale was discussed. A request for the window washing to be paid out of Library Building Repair Fund would be submitted to the town.

Anita moved and Kim seconded to approve the bid for window washing in the amount of \$770, \$350 to be requested from the Library Building Repair Fund for the full amount. If full amount not approved, the remainder will be paid for from the maintenance budget.

### 3) Policy

We will discuss and approve the Personnel Policy at this meeting. We will also discuss and review the policy schedule that Anita prepared.

## Action Items

### A. Discuss and vote on the heat pump for Meriden Library

The bid from ARC discussed at the 3/19 was further discussed. This work would be funded from the Meriden Library Building Fund.

MOTION— Anita moved and Kara seconded that we proceed with the bid from ARC in the amount of ?. The motion was unanimous and carried.

### B. Discuss meeting schedule

The meeting schedule for the remainder of the year was discussed and set as follows subject to change:

5/7 Meriden (Featured Library) 7pm  
5/14 PRML (Featured Library) 7pm  
6/11 Meriden (Trustee) 7pm  
7/9 PRML (Featured Library) 7pm  
7/16 Meriden (Featured Library) 7pm  
8/13 PRML (Trustee) 7:15pm  
9/10 Meriden (Featured Library) 7pm  
9/17 PRML (Featured Library) 7pm  
10/8 Meriden (Trustee) 7pm  
11/5 Meriden (Featured Library) 7pm  
11/7 PRML (Featured Library) 7pm  
12/10 PRML (Trustee) 7:15 pm

### C. Discussion of Personnel Policy with intent to vote

After discussion it was agreed that we would remove the line “Only those days earned may be utilized.” From section 6.2.2 on the accumulation of vacation pay and that the “Monthly Accumulation” column be removed from the charts in sections 6.2.1 and 6.3.1.

MOTION— Anita moved and Kara seconded that we proceed to remove the line “Only those days earned may be utilized” from section 6.2.2 on the accumulation of vacation pay and that the “Monthly Accumulation” column be removed from the charts in sections 6.2.1 and 6.3.1. of the personnel policy. The motion was unanimous and carried.

MOTION—Hillary moved and Mark seconded that we approve and adopt the Personnel Policy with the changes. The motion was unanimous and carried.

D. Discuss schedule of policy review

The schedule of policy review (attached) that Anita prepared was reviewed and discussed. Policy assignments were also reviewed.

E. Cataloging demo

It was agreed that the trustees that have not seen a demonstration of the cataloging process for automation will work out times with one of the Library Directors to do so.

F. Discussion: use of substitute hours for training, etc.

The Library Directors were encouraged to utilize sub hours as appropriate and necessary.

Go into Non-Public Session 9:16 p.m.

Return to Public Session 10:30 p.m.

Library Specific Meetings: May 7, 2012 Meriden Library 7:00 p.m.  
May 14, 2012 Philip Read Memorial Library 7:00 p.m.

Next Regular Meeting: June 11, 2012; Meriden Library 7:15 p.m.

Adjournment at 10:30 p.m.

BOARD OF TRUSTEES  
PLAINFIELD PUBLIC LIBRARIES  
March 19, 2012; 7:00 PM –  
Featured Library: Meriden Library  
*Draft Minutes*

Attending: Anita Brown, Mark Pensgen, Kimberly Moss, Hillary Sundell, Mary King (Director, Meriden Library)

Absent: Kara Toms

Members of the public: Dennis Girouard, Annamay Chapman

1. Call to Order at 7:01 p.m.
  - a. Roll call, introduction of guests, approval of agenda
  - b. Approval of Prior Minutes

3/12/12

MOTION— Mark moved and Hillary seconded that the minutes be received and approved as submitted. The motion was unanimous and carried.

- c. Correspondence  
Mary reported that there have been several Howard Zea Memorial contributions. Mary has replied to all the donors thanking them for their contributions. We will accept the gifts at the 4/9/12 meeting.
  - d. Public Comment [15 minutes]—none
  - e. Non-public session announcement—we will go into non public session per RSA 91-A:3, II(c)
2. Reports
    - a. Financial

Mark brought up the concern re: the lack of cash flow between year-end and town meeting. At the next meeting, we will discuss how we want to move to accounting under one treasurer and to one checking account as recommended by Terry Knowles. As we will be having only one treasurer, Mark suggested adding a “Finance Working Group” to our current list of working groups.

Mark has drafted an appropriation schedule that he will submit to the town.

Mark also handed out a year-end balance for Meriden. This will be posted on the websites along with the one for PRML.



Mark also went over a draft analysis of appropriations by year to reconstruct the Meriden fund balances. He has double-checked the books and his method of accounting does account for all the gifts we have a record of. Most of the building fund is in a Vanguard account split between both a money market fund and a stock fund. The bulk of the money is in the money market fund. We will need to consult with Terry Knowles to find out if a stock fund is an appropriate vehicle for this money. Mark has asked the town treasurer, Sarah Governo, to go over the draft analysis of appropriations by year to reconstruct the Meriden fund balances with him. She has agreed.

MOTION— Kim moved and Anita seconded that the report be accepted as submitted. The motion was unanimous and carried.

- b. Working Groups: --TABLED
  - i. Technology
  - ii. Personnel/Policy

3. Meriden Library: Detailed Discussion

- a. Director's Report

MOTION—Kim moved and Anita seconded that the report be accepted. The motion was unanimous and carried.

- b. Circulation Desk

A rough estimate for the circulation desk was around \$3000 from Home Depot. Mary explained her vision for the desk.

- c. The Friends of the Meriden Library

The steering committee has been meeting monthly on the 1<sup>st</sup> Monday night.

- d. Programming

Mary has started a “Mud Season” reading program for adults. Adults submit a book review and earn an entry for prizes at the Plant Sale at end of April. She would also like to do an adult program in May.

Mark mentioned the idea of doing a program on Kindles as it had been mentioned at the PRML meeting last week. Mary will contact the individual who did the presentation at Howe and coordinate with Nancy so that we could have the presentation at both libraries.

Mary has also mentioned that there are more limitations being put on ebooks or prohibitive pricing.

Mary has applied for a grant “Kids, Books and the Arts.” If the library receives the grant, it would pay for all but \$100 of a presenter she has already scheduled. We have received a gift designated for children’s programming so this would cover the cost if the grant does not come through.

Summer Reading Program “Dream Big. Read.” Mary is considering having a night-sky stargazing sleepover. She has already contacted some patrons who would be willing to lend their telescopes.

The Catamount Institute in Vermont has a 12-week program, “Healthy People, Healthy Planet,” that Mary has looked into before. She has had lots of interest, but cannot get commitments from twelve people as is required to have the program. She is coordinating with the Emily Cromwell, the Library Director in Cornish. With the two libraries working together, they do have the twelve people needed to commit. Six sessions will be at Meriden Library and six will be in Cornish.

e. Automation Update

Mary has now trained three volunteers. The training has taken a considerable amount of time. As she and Lori Estey have very little overlap in their schedules, she has been unable to train her before training the volunteers as she had hoped. She is hoping to train Lori this week. Mary is still working out a schedule for her volunteers. One volunteer has requested working while the library is closed. Mary is considering this.

As agreed upon at a Technology meeting with Mark, Kim, Mary and Nancy, books requiring editing of MARC records, books needing the z39.5 search engine to acquire the record, and new books will be the responsibility of staff. All other books will be cataloged by volunteers.

130 books are now in the system!

f. Building/Facilities

Mary has received a bid from a patron that is president of ARC mechanical contractors for air conditioning. Mary will forward the email to all the trustees. We will forward this to the Energy Committee. Kara will respond to the bid and contact the Energy Committee.

Mary’s biggest priority for the space is the reconfiguration of the upper level.

Mark mentioned having the town put in more hard pack on the west side of the building as well as cleaning up the parking lot after the winter. Mary will forward this info to Kara.

g. Zea Contributions

There have been several contributions made in Howard Zea’s memory. Mary has written to the family informing them of the donations. Mary is in discussion with the family as to their wishes for designating the purpose of the monies.

h. New Hampshire Small Libraries Summit

Mary is planning on attending the New Hampshire Small Libraries Summit 4/16/12. Cost is \$10.

4. Old or Unfinished Business

a. Sign approved policies

- i. Use of Library Bulletin Boards and Display Space
- ii. Reconsideration of Library Materials

- i. Review of Personnel Policy (with intention of voting for approval in March/April)  
As noted in the 3/12 meeting:

Bev Widger is rewriting the sections on Vacation and Sick Leave to reflect our current practice.

Anita and Kim plan to present the final draft of the Personnel Policy in April. The following changes need to be addressed:

Under Holidays—As President’s Day is not currently listed as a holiday and both libraries do take it as a holiday, we will change the “Floater Day” listed to President’s Day.

Background check—This is something that NHLTA recommends we do for both employees and volunteers. Bernadina suggested asking if volunteers/employees are approved through another organization. As the expense for this is not currently covered in the budget it was agreed that we would address it at the next review of the Personnel Policy.

We are working on adding a severe weather policy to the personnel policy. It was agreed that opening/closing the library should be at the LD’s discretion.

- j. Scheduling Library Director job evaluations  
As noted in the 3/12 meeting:

Anita explained that as the job evaluation has not been in place for a year that the job evaluation will be conducted as a performance review and goal setting session for each Library Director. The feedback will not be an official part of their personnel policy as a job evaluation would be.

Mark and Anita will schedule the performance reviews with each Library Director.

- k. AKB to discuss schedule of policy review—TABLED for April meeting

5. New business

- a. NHLTA Annual Conference

6. Announcements

4/2 will be Mary’s first day back from vacation.

We will be electing officers and assigning working groups at the April meeting. Mark encouraged us all to consider which positions and working groups we would like and be best suited for.

A group of 50 patrons surprised Mary with a party 3/13 in appreciation of her service and in honor of her two-year anniversary as Library Director at Meriden Library. Children brought pictures of what the library meant to them.

8. Next Regular meeting date: April 9, 2012; Philip Read Memorial Library; 7:15 p.m.
9. Go into non-public session per RSA 9-A:3 II, if necessary 8:35 p.m.

**Motion to enter Nonpublic Session** made by Anita, seconded by Mark

**Specific Statutory Reason** cited as foundation for the nonpublic session:

*RSA 91-A:3, II(c) Matters which, if discussed in public, would likely affect adversely the reputation of any person, **other than a member of this board**, unless such person requests an open meeting. This exemption shall extend to include any application for assistance or tax abatement or waiver of a fee, fine or other levy, if based on inability to pay or poverty of the applicant.*

**Roll Call vote** to enter nonpublic session:

- Anita Brown-Yes
- Mark Pensgen-Yes
- Kimberly Moss-Yes
- Hillary Sundell-Yes

**Motion made to seal minutes** made by Hillary, seconded by Anita, because it is determined that divulgence of this information likely would adversely affect the reputation of any person other than a member of this board.

**Roll Call Vote to seal minutes:**

- Anita Brown-Yes
- Mark Pensgen-Yes
- Kimberly Moss-Yes
- Hillary Sundell-Yes

**Motion: PASSED**

**Motion to leave nonpublic session** and return to public session by Kim, seconded by Mark.

**Motion: PASSED**

**Public session reconvened** at 9:20 p.m.

10. Adjournment at 9:25 p.m.

BOARD OF TRUSTEES  
PLAINFIELD TOWN LIBRARIES  
March 5, 2012; 6:30 PM – Town of Plainfield Selectboard Meeting  
*Approved Minutes*

Attending: Anita Brown, Mark Pensgen, Bernadina Webber, Kimberly Moss

Absent: Kara Toms

We attended the Selectboard meeting to discuss our 3/5/2012 meeting with Terry Knowles, Assistant Director, Department of the Attorney General, Charitable Trusts Unit. Anita read the summary of the meeting findings.

Questions were asked and answered from both the Selectboard and public.

BOARD OF TRUSTEES  
PLAINFIELD TOWN LIBRARIES  
February 27, 2012; 6:30 PM – Meriden Library  
*Approved Minutes*

Attending: Anita Brown, Mark Pensgen, Kara Toms, Bernadina Webber, Kimberly Moss

Members of the public: Beverly Widger, Diane Rogers, Pam Abrahamson, Lee Abrahamson, Richard L Rogers, Hillary Sundell, Robert Sundell, Ruth Stalker, Nancy Norwalk, Jesse Stalker, Dennis Girouard, Judy Durant, Steve Halleran, Mary King.

A. Call to Order: 6:30pm

B. Public Comments

Response to Letter from Diane Rogers read at 2/13/2012 Trustee Meeting

Mark clarified that Diane’s reference to “the first joint session by the trustees” in her 2/13/2012 letter to the trustees was referring to the first joint meeting of the boards of the two libraries prior to the boards merging.

Diane further explained her intentions in writing the letter—that she acted alone, did not intend it to cause harm, and was motivated by a concern over Meriden funds that had ceased to be included in the town reports. Diane suggested that the Library Board of Trustees amend this year’s town report to reflect all encumbrances, accounts and the budget for each library.

Mark first addressed that this issue has been addressed as shown in the public record. He explained that the Meriden BOT started dealing with this issue at the end of the 2010 year. He further explained that the extra funds have been listed in the town report until 2008. Mark did not include these funds in the town report starting in 2009 because he was only thinking he needed to report “P and L”, (profits and loss). Pam Abrahamson said that she prepared the 2008 statement for the 2009 town report and that she the best she knew how.

Mark shared a copy of the email showing that he did contact Terry Knowles, Assistant Director of Charitable Trusts 10/12/10. This discussion was referred to in the Meriden Library 10/18/2010 minutes. Mark read the following from those minutes, “Mark spoke with Terry Knowles regarding library funds. She says to go by whatever the selectboard says. Steve Halleran and the town auditor (Sherry) have given us the okay for keeping any rolled-over funds from previous years.”

Diane was concerned specifically about the building fund. She was reassured by Mark and Pam Abrahamson that the money is still there and has not been expended.

Bev Widger asked how long the funds were not properly encumbered. Mark explained that he has gone back as far as 1990, but it will be more difficult to go back farther. From what he can tell based on the balance it doesn’t appear to go back much farther than that. Mark is finding it

difficult to discern which of the funds in question are from appropriated funds vs. which are from donated funds.

Anita explained that the board of trustees is in the process of setting up an appointment with Terri Knowles, Assistant Director of Charitable Trusts to review the findings and develop a plan of action for any required resolution.

Jesse Stalker asked if these funds were included in the town audit. Mark explained that bank statements from each account that Meriden Library holds were included in every annual audit. Dennis Girouard asked if the BOT would consider doing an additional audit of the books after Mark has gone through the books. Lee Abrahamson did not feel an additional audit was necessary or appropriate. Robert Sundell said that as long as all the funds were included in the annual town audit that an additional audit would not be necessary.

Bernadina summarized that based on our discussion so far it was clear that the board of trustees should include all funds in the town report and monthly treasurer's report. Bev Widger further asked that it be clear which funds were donated monies vs. appropriated monies. Mark said that he plans to go back and separate the two and would like to review his findings with Bernadina. Bernadina said that once we had a good number we could have Terry Knowles review our findings.

Steve Halleran reported that he spoke with Terry Knowles on Friday (2/24/2012) and his understanding was that the concern was that private monies be separated and not put with town monies.

Judy Durant reported that when she took over the books there were two categories listed—one for contributions and one for building fund and that she may have combined these two categories into one when she took over. She did note that the memo for each deposit should clarify what type it is.

To summarize, the board will take the following actions resolve this issue:

- an accounting of all public and privately sourced funds will be done with the best available data
- members of the board will meet with Terry Knowles to review the findings and develop a plan of action for any required resolution
- the board will include balance sheets in future financial reports
- the board will include in a future public meeting a report on the steps indicated above

#### C. Monthly Reports:

1. Secretary's

a. Approval of February 13 minutes

MOTION— Bernadina moved and Kara seconded that the minutes be received and approved as submitted. The motion was unanimous and carried.

D. Go into non-public session per RSA 9-A:3 II

7:25 pm

MOTION—Anita moved and Kim seconded to go into non-public session per RSA 91-A:3 II (c). The vote was as follows: Mark-Yes, Kara-Yes, Bernadina-Yes, Kim-Yes, Anita-Yes. The motion was unanimous and carried.

11:22 pm

MOTION—Bernadina moved and it was seconded to return to public session per RSA 91-A:3 II. The vote was as follows: Mark-Yes, Kara-Yes, Bernadina-Yes, Kim-Yes, Anita-Yes. The motion was unanimous and carried.

MOTION—Anita moved and Kim seconded per RSA 91-A:3 III to seal the minutes from the non-public session. The vote was as follows: Mark-Yes, Kara-Yes, Bernadina-Yes, Kim-Yes, Anita-Yes. The motion was unanimous and carried.

E. Adjourn: 11:23pm

Next meeting: March 12; 7:00 PM; Philip Read Memorial Library



BOARD OF TRUSTEES  
PLAINFIELD TOWN LIBRARIES  
February 13, 2012; 7:15 PM – Meriden Library  
Approved Minutes

Attending: Anita Brown, Mark Pensgen, Kara Toms, Bernadina Webber, Mary King (Director, Meriden Library), Nancy Norwalk, (Director, Philip Read Memorial Library)

Attending via Skype: Kimberly Moss

Members of the public: Dennis Girouard

A. Call to Order 728pm

B. Public Comments

Dennis had questions as to how and when the 1/18/2012 meeting had been publicly posted. Kim informed him that the meeting had been posted to the town website on 1/17/2012.

Anita read a letter from Diane Rogers asking a question about Meriden Library funds.

MOTION— Kara moved and Mark seconded that we table discussion on this topic and respond at a future meeting. The motion was unanimous and carried.

Kim will email Diane and let her know that the Board of Trustees is working on a response.

C. Monthly Reports:

1. Secretary's
  - a. Approval of January 9 minutes

MOTION— Bernadina moved and Mark seconded that the minutes be received and approved as submitted. The motion was unanimous and carried.

- b. Approval of January 18 minutes

MOTION— Kara moved and Bernadina seconded that the minutes be received and approved as submitted. The motion was unanimous and carried.

2. Treasurers'

MOTION—Mark moved and Kara seconded that the reports be accepted. The motion was unanimous and carried.

3. Directors'

a) Meriden

Mary would like more direction on when to close because of weather. It was agreed that we would discuss this at a future meeting.

MOTION— It was moved and seconded that the Library Director's report be received and accepted as submitted. The motion was unanimous and carried.

b) Philip Read

MOTION— Anita moved and Bernadina seconded that the Library Director's report be received and accepted as submitted. The motion was unanimous and carried.

D. Committee Reports:

1. Facilities

a) The bid from Emily Electric for work at Meriden Library was discussed.

MOTION— Anita moved and Bernadina seconded that we approve everything but the generator portion of the bid for no more than \$393.00. The motion was unanimous and carried.

b) Nancy asked if Kara had been successful in getting bids for window washing. Kara replied that she would resume seeking bids.

c) Discussion of generator options at and funding for a generator at Philip Read took place. It was agreed to continue this discussion at another time.

d) The energy audit report to the Selectmen and Plainfield Energy Committee will be scheduled for either 2/29 or 3/1 at the Meriden Town Hall.

e) Bernadina has heard from Jonathan at Estes & Gallup that construction at Philip Read will resume in mid-March.

2. Policies—no report

Bev Widger volunteered and has been working with Anita and Kim in the drafting of the Personnel Policy that will be discussed tonight.

3. Technology

Mary and Nancy reported that the software from Equinox has been downloaded and that they have been trained to begin cataloging the library holdings.

#### E. Old Business

##### 1. Staff Luncheon

The Staff Luncheon 1/21/12 was appreciated by the employees. All the employees were able to attend except Annamay Chapman from Meriden Library.

##### 2. Review of Personnel Policy (with intention of voting for approval at March mtg)

MOTION— Bernadina moved and Mark seconded that revise the personnel policy so that sick pay accrues at the same rate as vacation pay. The motion was unanimous and carried.

##### 3. Anita to discuss schedule of policy review

Anita will send out a calendar and schedule for reviewing the remaining policies.

Nancy pointed out that some of the approved policies still need signature pages with an approval date.

#### F. New Business

##### 1. Scheduling Library Directors job evaluations

After discussion the following schedule for completing the Library Directors' job evaluations was agreed upon:

2/14—Kim will send out

1) the Trustee version of the job evaluations and Library Director job description to all trustees

2) the self-evaluation and Library Director job description to Mary and Nancy.

2/21—All of the above evaluations are to be completed and sent to Anita.

2/22—Kim and Anita will meet to tabulate the trustee versions of the job evaluations for each Library Director

2/27—The trustees will meet in a non-public session to review the job evaluation for each Library Director.

Mark and Anita will then meet to review the job evaluation with each Library Director.

Kara noted that with the trustee election cycle and the duties of the board in the fall, the January/February timeframe is a good time to conduct job evaluations.

2. Discussion: Library Aide job descriptions and evaluations

Mary and Nancy were asked to work on updating job description and job evaluation for the Library Aides.

3. Mike Sutherland website training

Kim explained that Mike Sutherland has offered to train a trustee how to post the bullet points of our activity on the website. Mark volunteered to be the trustee to do this. Kim will forward Mike's contact information to Mark.

4. New format for agenda—TABLED.

5. Discussion of meeting schedule

After discussion, it was agreed to try the format of 3 trustee meetings every 2 months. One month we will have two meetings (a meeting for each library focusing on its individual needs.) The following month we will have one meeting more focused on trustee business.

March 12, PRML 7pm

March 19, Meriden 7pm

April 9, PRML Joint 7:15pm

6. Library system name

There was discussion as to an appropriate name for the library system including the Meriden Library and Philip Read Memorial Library.

MOTION— Kara moved and Kim seconded that we adopt the name of "Plainfield Public Libraries" as the name for the library system encompassing both the Meriden Library and Philip Read Memorial Library. The motion was unanimous and carried.

H. Next meeting: February 27; 7:00 PM; Meriden Library

Adjourn: 9:28pm

BOARD OF TRUSTEES  
PLAINFIELD TOWN LIBRARIES  
January 18, 2012; 6:15 PM – Meriden Library  
Approved Minutes

Attending: Anita Brown, Kimberly Moss, Mark Pensgen Kara Toms (arrived at 6:48pm), Bernadina Webber, Mary King (Director, Meriden Library), Nancy Norwalk, (Director, Philip Read Memorial Library)

- A. Call to Order: 6:34pm
- B. Old Business

- 1. Budget Discussion and Revote

Bernadina reviewed the calculations for the additional funds to provide sick leave, vacation pay and holidays at both libraries. The correct figure is not \$2100 as originally thought, but \$761.

MOTION— Anita moved and Kara seconded to rescind the 1/9 vote to amend the appropriation by \$2100, the effect of which is to leave the original appropriation request of \$111,149 in effect. The vote was as follows:

Mark-Yes, Kara-Yes, Bernadina-Yes, Anita-Yes, Kim-Yes  
The motion was unanimous and carried.

- 2. Library Director Job Description

MOTION— Anita moved and Kara seconded to approve the Library Director Job Description as submitted. The vote was as follows:

Mark-Yes, Kara-Yes, Bernadina-Yes, Anita-Yes, Kim-Yes  
The motion was unanimous and carried.

- 3. Library Director Job Evaluation

After discussion the Library Director Job Evaluations were changed and corrected.

MOTION— Bernadina moved and Kim seconded to approve the Library Director Job Evaluations as amended. The vote was as follows:

Mark-Yes, Kara-Yes, Bernadina-Yes, Anita-Yes, Kim-Yes  
The motion was unanimous and carried.

- C. New Business

- 1. Memorandum of Understanding

Bernadina and Mark are drafting an agreement between the Selectmen and the Library Board of Trustees that specifies that any fund balance over 5% of our total appropriation will not be held by the libraries, but instead returned to the town.

2. Scheduling “End of Year” Budget Meeting

Anita asked about the possibility of having an end-of-year budget review. After discussion, Mark offered to go over the budget with any other trustee that felt the need.

D. Adjourn 7:13pm

BOARD OF TRUSTEES  
PLAINFIELD TOWN LIBRARIES  
January 9, 2012; 6:45 PM – Philip Read Memorial Library  
Approved Minutes

Attending: Anita Brown, Kimberly Moss, Kara Toms, Bernadina Webber, Mary King (Director, Meriden Library), Nancy Norwalk, (Director, Philip Read Memorial Library)

Absent: Mark Pensgen

Members of the public: Dennis Girouard, Bev Widger

A. Call to Order 6:54pm

B. Public Comments--none

C. Monthly Reports:

1. Secretary's

MOTION— Kara moved and Bernadina seconded that the minutes be received and approved as submitted. The vote was Yes-4, No-0, Absent-1 and carried.

2. Treasurer's Report for Philip Read Memorial Library

Books are due to the auditors 1/13.

MOTION— It was moved and seconded that the report be accepted. The vote was Yes-4, No-0, Absent-1 and carried.

3. Directors'

PRML

Meriden

The NH state system for cataloging has been down for several weeks. The Library Directors are not able to add or delete holdings.

MOTION— Kim moved and Bernadina seconded that the minutes be received and accepted with the following changes.

PRML—Change item #6 to read Philip Read Memorial Library instead of Plainfield Library

Meriden—Change "November statistics" in the first paragraph to read "December statistics"

The vote was Yes-4, No-0, Absent-1 and carried.

D. New Business

1. Staff Lunch Meeting
  - a. Date: January 21
  - b. Time: 12:30-2:00pm
  - c. Place: PRML
  - d. Plan of Action

Kara will work on the menu. Anita will organize the talking points. We plan to go over the personnel policy (even if in draft form) and listen to any employee input.

2. Town Reports:

Mary is preparing the town report for Meriden Library. Nancy provided a list of items so that Anita can prepare the town report for Philip Read Memorial Library. Anita will also prepare the summary report of board activities for the year.

3. Trustee Election—Candidates

After discussion and looking at the RSAs it should be two 3-year terms that are to be up for election in March. Bernadina will follow-up with Steve Halleran.

E. Old Business

1. Approving Use of Materials Policy

Bernadina presented the “Policy: Use of Library and Library Materials” as discussed and changed at the last meeting.

MOTION— Anita moved and Bernadina seconded that policy be approved as submitted. The vote was Yes-4, No-0, Absent-1 and carried.

2. Fee Schedule

MOTION— Anita moved and Bernadina seconded that fee schedule be approved as submitted. The vote was Yes-4, No-0, Absent-1 and carried.

3. Personnel Policy—Review

Bev Widger was here to consult with re: the personnel policy. After discussion it was agreed that Anita and Kim meet with Bev separately to present a more concrete draft to the board.



MOTION— Anita moved and Bernadina seconded that all library employees receive sick leave and vacation hours and be paid for legal holidays if they fall on a regular work day. The vote was Yes-4, No-0, Absent-1 and carried.

#### 4. Library Director Job Evaluations (Trustee, Staff and Self evaluations) and Job Description.

At Bev Widger's suggestion, the Library Director job evaluations will be revised to include evaluation criteria for long range planning and to change from a rating scale of 5 to 3.

The Library Director job evaluations and job description will be emailed and put for a Yes/No vote.

#### 5. End of Year Budget Funds

MOTION— Anita moved and Kim seconded that we approve \$469 bid submitted by Dave Grobe for repairs at Philip Read. The vote was Yes-4, No-0, Absent-1 and carried.

As the books and encumbrances are due to the auditors and the town this week we need to make a decision re: PRML unspent funds.

The following items were discussed as possibilities for encumbrances for Philip Read Memorial Library:

\$400 Sentinel fire alarm inspection

\$650 NHSL card catalog

\$500 Equinox bill

\$469 for maintenance for Dave Grobe to complete repairs as per bid.

5. The Town of Plainfield will be giving employees a raise of 2.5%. The Board planned for a 2% raise when asking for the appropriation from the town. The Board discussed our options.

MOTION— Anita moved and Kim seconded to amend the 2012 appropriation by \$2100 to cover the additional .5% raise and realignment of benefits. The vote was Yes-4, No-0, Absent-1 and carried.

#### 6. Time Cards

Anita presented a time card for employees to start using. There was discussion of library employees using a more detailed time card which would be in compliance with New Hampshire Department of Labor regulations. Bernadina will check with the Town on this.

F. Next meeting: February 13, 2012; 7:15 PM; Meriden Library

Adjourn: 10:05 pm